



ABN 43 064 478 842

231 Osborne Avenue Clayton South, VIC 3169
PO Box 1548, Clayton South, VIC 3169
t 03 9265 7400 f 03 9558 0875
freecall 1800 680 680
www.tmgtestequipment.com.au

Test & Measurement

- > sales
- > rentals
- > calibration
- > repair
- > disposal

Complimentary Reference Material

This PDF has been made available as a complimentary service for you to assist in evaluating this model for your testing requirements.

TMG offers a wide range of test equipment solutions, from renting short to long term, buying refurbished and purchasing new. Financing options, such as Financial Rental, and Leasing are also available on application.

TMG will assist if you are unsure whether this model will suit your requirements.

Call TMG if you need to organise repair and/or calibrate your unit.

If you click on the "Click-to-Call" logo below, you can call us for FREE!

TMG Corporate Website

TMG Products Website



Click-to-Call
TMG Now



Product Lifecycle Management System

Disclaimer:

All trademarks appearing within this PDF are trademarks of their respective owners.



Mini-OTDR

FTB-100B



Rugged, splashproof unit

Modular design for field use

High-quality touchscreen

Wide variety of OTDR modules



Fiber-optic test,
measurement, monitoring
and automation solutions

EXFO

High-Performance OTDR in an Easy-to-Use Package

The FTB-100B is a mini-OTDR that supports all of EXFO's OTDR modules. The FTB-100B has the features you need, whether you're an intensive or occasional OTDR user.

Key Features

- Monochrome or color touchscreen
- Integrated power meter
- Internal memory of 700 traces
- Additional storage capacity of up to 6000 traces
- Standard floppy drive and PCMCIA port
- Over eight hours battery operating time



Rugged Platform

The FTB-100B is built to handle even the harshest field conditions. Its sturdy design allows it absorb the hits and shocks that are par for the course in outside plant testing. Splashproof casing makes the FTB-100B a high-performance, all-weather instrument.



PC Connectivity

The FTB-100B is supported by Windows CE, a compact operating system used in personal digital assistant and palmtop PC products. Ideal for portable test equipment, Windows CE provides superior power management, data storage and transfer, and PC connectivity.



Durable Touchscreen

The FTB-100B's touchscreen gives fast access to all menus and functions; with the FTB-100B each function is only a touch away. Tested to endure over a million touches in one spot without failure, the touchscreen offers many times the durability of push buttons.



Modular Flexibility

The FTB-100B hosts the OTDR module of your choice. Optical modules can be swapped without tools in a matter of seconds. Reconfigure the test set easily anywhere, anytime, as often as you need. FTB-100B modules are also compatible with the FTB-400 Universal Test System, so multiple users can share one module.

Top-of-the-Line OTDR Performance

EXFO offers a variety of singlemode OTDR modules at four essential wavelengths—1310 nm, 1550 nm, 1625 nm, and 1410 nm—to cover all fiber applications from long-haul and WDM to metropolitan networks. The FTB-100B is also ideal for LAN applications because it can host multimode OTDR modules.

EXFO's OTDR modules offer an impressive dynamic range with short dead zones to meet today's stringent network test requirements. OTDR modules perform rapid acquisitions with low noise levels enabling accurate low-loss splice location. An OTDR trace, consisting of up to 52 000 points, provides a sampling resolution as small as 8 cm. This unmatched sampling capability produces optimal resolution for even the longest distances. Each OTDR module provides a stable light source, a power meter, as well as the option to add a visual fault locator.

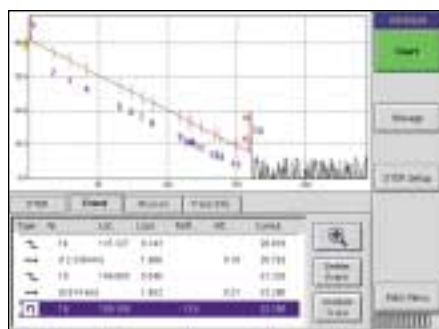

High-Performance OTDR Modules

- Full range of singlemode and multimode modules
- Dynamic range up to 45 dB
- Triple-wavelength OTDR files
- Four-point loss measurements
- ORL calculation
- Pass/Fail test result validation
- Universal connector interface
- Visual fault locator

Integrated Power Meter

EXFO delivers another all-in-one solution. The FTB-100B comes complete with an integrated power meter to optimize your field performance and efficiency. This practical InGaAs detector power meter is as accurate as our popular handheld power meters and features calibrated wavelengths of 850 nm, 1300 nm, 1310 nm, 1550 nm and 1625 nm.

With one rugged platform, you can accurately measure insertion loss, and precisely detect and analyze splices, connectors, breaks and other events along a fiber.

With the integrated power meter, the FTB-100B now offers:

- Power measurements in dB, dBm, and watts
- Easy wavelength selection
- Quick save
- Quick print



Professional Data Management

- Convenient result tables
- Produce high-quality documents in minutes
- Download data to your PC or the FTB-400 via the RS-232 port
- Compatible with ToolBox Office multiple testing software
- View, export or print your data



A Complete OTDR Software Application

All the OTDR Modes You'll Need

The FTB-100B's OTDR software is designed for simplicity and automation. Three operation modes meet all your OTDR testing needs:

- Auto mode lets you select acquisition parameters automatically. Perfect for basic, repetitive OTDR applications or for occasional users.
- Advanced mode offers more flexibility with multiple setup and measurement capabilities. Change index of refraction and helix factor settings for optimal distance measurements.
- Template Trace mode compares each acquisition with a designated template for complete cable testing and documentation.

Automatic Data Synchronization

Transferring data between a mini-OTDR and a PC has never been easier. Connect the serial cable to the FTB-100B and data synchronization begins automatically.

Immediate Pass/Fail Test Result Validation

Submit fiber test results for Pass/Fail validation to ensure that data does not exceed user-defined thresholds such as splice loss, total loss, and backreflection. The OTDR automatically validates results for faster, more reliable testing.

As easy as 1-2-3!

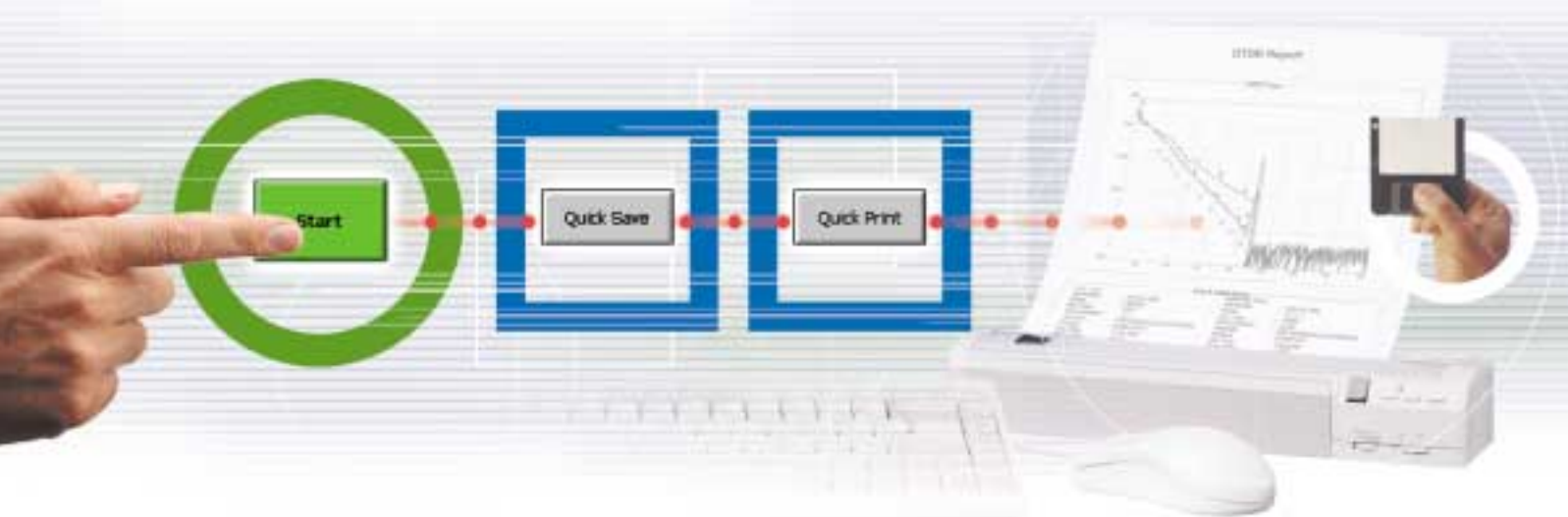

Press **Start**, and Auto mode sets test parameters, performs single- or dual-wavelength OTDR testing, and issues detailed results.

The one-button **Quick Save** feature with automatic trace-naming completes the test routine.

The **Quick Print** function automatically issues a complete test report.

ToolBox Office PC Emulation Software for Post-Processing

Performing data post-processing with optional ToolBox Office software gives you more OTDR processing functions.

Bidirectional Trace Analysis*

Improve the accuracy of your loss measurements with the bidirectional averaging feature, which uses OTDR acquisitions from both ends of a fiber span to average loss results for each event.

* Available on singlemode OTDRs only.

Efficient Multifiber Testing with Template Trace

Save testing time when commissioning a large number of fibers by using the template trace feature. Template Trace mode dynamically compares new OTDR results with a trace you assign as a reference. Reference trace documentation is automatically pasted onto new acquisitions to save you time.

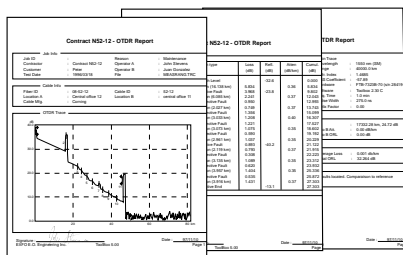
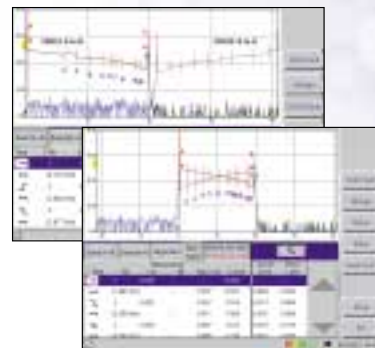

Professional Report Generation

User-configurable test reports and batch printing let you generate complete, professional OTDR reports quickly and efficiently.

Export OTDR Files in Bellcore or ASCII Format

Save and load OTDR test results in the Bellcore-standard OTDR record format. Export results in ASCII or ASCII+ format to spreadsheet or wordprocessing applications.

More Power with ToolBox Office Pro

Optional ToolBox Office Pro software accelerates data postprocessing by as much as 90 % with two key utilities: batch processor and cable report generator. ToolBox Pro is available in convenient CD format.

Batch Processor



- Data analysis
- File conversion
- Printing and saving
- Bidirectional OTDR averaging
- Template trace comparison
- Zoom function
- Document operation photo: batch processor screen shot

Cable Report Generator

Event	Loss	Attenuation	...
FC101	0.18	0.18	...
FC102	0.18	0.18	...
FC103	0.18	0.18	...
FC104	0.18	0.18	...
FC105	0.18	0.18	...
FC106	0.18	0.18	...
FC107	0.18	0.18	...
FC108	0.18	0.18	...
FC109	0.18	0.18	...
FC110	0.18	0.18	...
FC111	0.18	0.18	...
FC112	0.18	0.18	...
FC113	0.18	0.18	...
FC114	0.18	0.18	...
FC115	0.18	0.18	...
FC116	0.18	0.18	...
FC117	0.18	0.18	...
FC118	0.18	0.18	...
FC119	0.18	0.18	...
FC120	0.18	0.18	...

- Event table compiles all event measurements
- Fiber table provides attenuation values for each fiber and fiber section of a cable
- Fault table lists all events and measurements exceeding user-defined thresholds
- Report available in PDF and Excel format

FTB-100B Mini-OTDR Specifications

Processor	Intel StrongArm, 206 MHz	
Interfaces	Serial RS-232C	Parallel printer
External	Keyboard PS/2	PCMCIA Type II
Internal memory ¹	32 MB total (700 traces typ.), standard	
Additional storage (optional)	PCMCIA flash cards, up to 6000 traces	
Floppy drive	3.5 inch floppy drive, 1.44 MB	
Display	Monochrome LCD touchscreen, 18.8 cm (7.4 in), 640 x 480, transfective Color LCD touchscreen, 19.6 cm (7.7 in), 640 x 480, 256 colors (optional)	
Touchscreen	Resistive, 8 wires Positional accuracy better than 2 %, full scale, worst-case error < ± 0.5 cm (0.18 in) Resistant to most common chemicals ²	
External power supply	AC input: 100 to 240 V, 50 Hz to 60 Hz	
Battery	Nickel metal-hydride (NiMH), rechargeable, smart (standard)	
Battery operating time ³	8 h - NiMH battery	
Recharge time	2.5 h (off), 8 h (on)	
Size (H x W x D)	21.6 cm x 33.6 cm x 8.9 cm	(8 1/2 x 13 1/4 x 3 1/2 in)
Weight ⁴	3.7 kg	(8.1 lb)
Operating temperature ⁵	-5 °C to 50 °C	(23 °F to 122 °F)
Storage temperature ⁶	-40 °C to 60 °C (-40 °F to 140 °F) (shipping)	-20 °C to 50 °C (-4 °F to 122 °F) (long term)
Relative humidity	0 to 95 % max. non-condensing	

Power Meter Specifications (InGaAs detector)

Calibrated wavelengths (nm)	850, 1300, 1310, 1550, 1625
Power range (dBm)	4 to -70
Uncertainty (%)	± 5 (0 dBm to -46 dBm)
Linearity (dB)	± 0.05 (0 dBm to -46 dBm) ± 0.1 (-46 dBm to -57 dBm)
Display resolution (dB)	0.01 (4 dBm to -63 dBm) 0.1 (-63 dBm to -70 dBm)
Tone detection (Hz)	270/1000/2000

FTB-100B Product Information

Ordering Information and Price List (Platform)

Standard features

- 18.8 cm (7.4 in) monochrome LCD (transfective)
- Touchscreen display
- 700-trace internal OTDR storage (approx.)
- 3.5 in floppy drive
- PCMCIA interface for flash memory card
- Semi-rigid carrying case (not included if rigid case is ordered)
- AC adapter/charger
- NiMH smart battery
- Serial cable: null modem cable, DB9F to DB9F
- Free software upgrades for one year

FTB-100B-N4-ZZ-Options

ZZ = Specify language choice:
GA = English, French, Spanish,
 German, Italian, Czech and Russian
GB = Traditional Chinese and GA
GC = Simplified Chinese and GA

D2 = 19.6 cm (7.7 in) color touchscreen
RC = Rigid carrying case (replaces standard, semi-rigid case)
PM-XX = Power Meter InGaAs detector XX: FOA-**XX** type selection

Specify the FOA adapter type you wish to obtain.

(one free adapter included)

Example: PM-22 for power meter option with FC type FOA

FOA-12	Biconic
FOA-14	D4: D4, D4/PC
FOA-16	SMA/905, SMA/906
FOA-22	FC: FC, FC(/PC/SPC/UPC/APC), NEC-D3
FOA-32	ST: ST, ST(/PC/SPC/UPC)
FOA-34	Mini-BNC
FOA-40	Diamond HMS-0, HFS-3 (3.5 mm)
FOA-54	SC: SC(/PC/SPC/UPC/APC)
FOA-84	Diamond HMS-10, HFS-13

For other FOA types, please contact EXFO.

Notes:

1. With GC language option, total internal storage is 550 traces (typical).
2. Heptane, ethanol, isopropanol, acetone, methyl ethyl ketone, cellosolve acetate, toluene, carbitol acetate, hydrochloric acid, turpentine, Vm and naptha, unleaded gasoline, motor oil, diesel fuel, transmission fluid, antifreeze.
3. According to Telcordia TR-NWT-001138, with monochrome display.
4. FTB-100B with OTDR module and battery.
5. Excluding floppy drive (use is not recommended below 0 °C). OTDR module performance can be affected at sub-zero temperatures.
6. Excluding the battery.

Accessories

GP-10-034	Spare semi-rigid carrying case	GP-287(A-E-I-S-U)	External battery charger for smart battery (requires external AC adapter/charger) Specify: A-North America, E-Europe, I-India, S-Australia and New Zealand, U-United Kingdom
GP-10-035	Spare rigid carrying case	GP-288 (A-E-I-S-U)	Spare external AC adapter/charger for FTB-100B Specify: A-North America, E-Europe, I-India, S-Australia and New Zealand, U-United Kingdom
GP-216	Null modem cable, DB9F to DB9F	GP-297	CANON BJC-50 Printer including parallel cable Specify: A-North America, E-Europe, I-India, S-Australia and New Zealand, U-United Kingdom
GP-219	External keyboard		
GP-225	FTB power cable for vehicle cigarette lighter (12 V)		
GP-281	16 MB ATA flash card (500 traces typ.)		
GP-282	32 MB ATA flash card (1000 traces typ.)		
GP-283	80 MB ATA flash card (3000 traces typ.)		
GP-284	160 MB ATA flash card (6000 traces typ.)		
GP-285	Spare NiMH smart battery		

Specifications

OTDR Multimode Module Specifications¹

Wavelength (nm)	Dynamic range ² (dB) at 100 ns/1 μs	Event dead zone ³ (m)	Attenuation dead zone ³ (m)	Model
850 ± 20/1300 ± 20	23/27 (C), 25/29 (D)	1.5/1.5	5/5	FTB-7212B-C or D ⁷

OTDR Singlemode Module Specifications¹

Wavelength (nm)	Dynamic range ² (dB) at 10 μs	Dynamic range ² (dB) at 20 μs	Event dead zone ⁵ (m)	Attenuation dead zone ⁵ (m)	Model
Single-Dual-Wavelength module					
1310 ± 20/1550 ± 20	32/31	-	3/3	10/15	FTB-7223B-B ⁷
1310 ± 20/1550 ± 20	37.5/35.5	38.5/37.5	3/3	10/15	FTB-7323B-B
1310 ± 20/1550 ± 20	40/38	41.5/39.5	3/3	10/15	FTB-7423B-B
1310 ± 20/1550 ± 20	43.5/41.5 ⁴	45/43 ⁴	3/3	10/15	FTB-7523B-B
1410 ± 10	37	38.5	3	10	FTB-7405B-B
1550 ± 20	42	43.5	3	15	FTB-7503B-B-ER
1625 ± 10	35	36	3	16	FTB-7304B-B
1625 ± 10	38	39	3	16	FTB-7404B-B
1625 ± 10	40	41.5	3	16	FTB-7504B-B
1550 ± 20/1625 ± 10	35.5/35	37.5/36	3/3	15/16	FTB-7334B-B
1550 ± 20/1625 ± 10	40/38	40.5/39	3/3	15/16	FTB-7434B-B
1550 ± 20/1625 ± 10	42/40	43.5/41.5	3/3	15/16	FTB-7534B-B
Triple-Wavelength module					
1310 ± 20/1550 ± 20/1625 ± 10	41/39/38	42.5/40.5/39.5	3/3/3	8/10/10	FTB-74234C-B

Other OTDR configurations are available. Contact your EXFO representative for more information.

General Specifications

Models	200B-C/D series	200B-B series	300B-B/400B-B/ 500B-B/4234C-B series
Distance range (km)	0.625, 1.25, 2.5, 5, 10, 20, 40	1.25, 2.5, 5, 10, 20, 40, 80, 160	1.25, 2.5, 5, 10, 20, 40, 80, 160, 260
Pulse width (ns)	850 nm: 10, 30, 100 1300 nm: 10, 30, 100, 275, 1000	10, 30, 100, 275, 1000, 10 000	10, 30, 100, 275, 1000, 2500, 10 000, 20 000
Linearity ⁸ (dB/dB)	± 0.05	± 0.05	± 0.05
Loss threshold (dB)	0.01	0.01	0.01
Loss resolution (dB)	0.001	0.001	0.001
Sampling resolution (m)	0.08 to 5	0.08 to 5	0.08 to 5
Sampling points	Up to 16 000	Up to 32 000	Up to 52 000
Distance uncertainty ⁶	± (1 m + 0.0025 % x distance)	± (1 m + 0.0025 % x distance)	± (1 m + 0.0025 % x distance)
Measurement time	User-defined (60 min maximum)	User-defined (60 min maximum)	User-defined (60 min maximum)
Real-time refresh	< 1 s	< 1 s	< 1 s
Stable source output power ⁹ (dBm)	-7	-10	-5
Visual fault locator (optional)	Laser, 650 ± 10 nm CW, P _{out} maximum: 800 μW	Laser, 650 ± 10 nm CW, P _{out} maximum: 800 μW	Laser, 650 ± 10 nm CW, P _{out} maximum: 800 μW

Notes

- All specifications are for a temperature of 23 °C (73 °F) with a FC/PC connector unless otherwise specified.
- Typical dynamic range with a three-minute average at SNR = 1.
- Typical dead zone of multimode modules for reflectance below -35 dB, using a 10 ns pulse.
- Typical dynamic range on NZDSF with a three-minute average at SNR = 1.
- Typical dead zone of singlemode modules for reflectance below -45 dB, using a 10 ns pulse.
- Does not include uncertainties due to fiber index and sampling resolution.
- ORL measurement not available for this module.
- Does not include uncertainty due to sampling resolution.
- Typical output power value.

Safety



LASER SAFETY

21 CFR 1040.10
IEC 60825-1:Ed.1:1998

CLASS 1 LASER PRODUCT
CLASS 3A LASER

Ordering Information

Single and Dual Wavelength OTDR

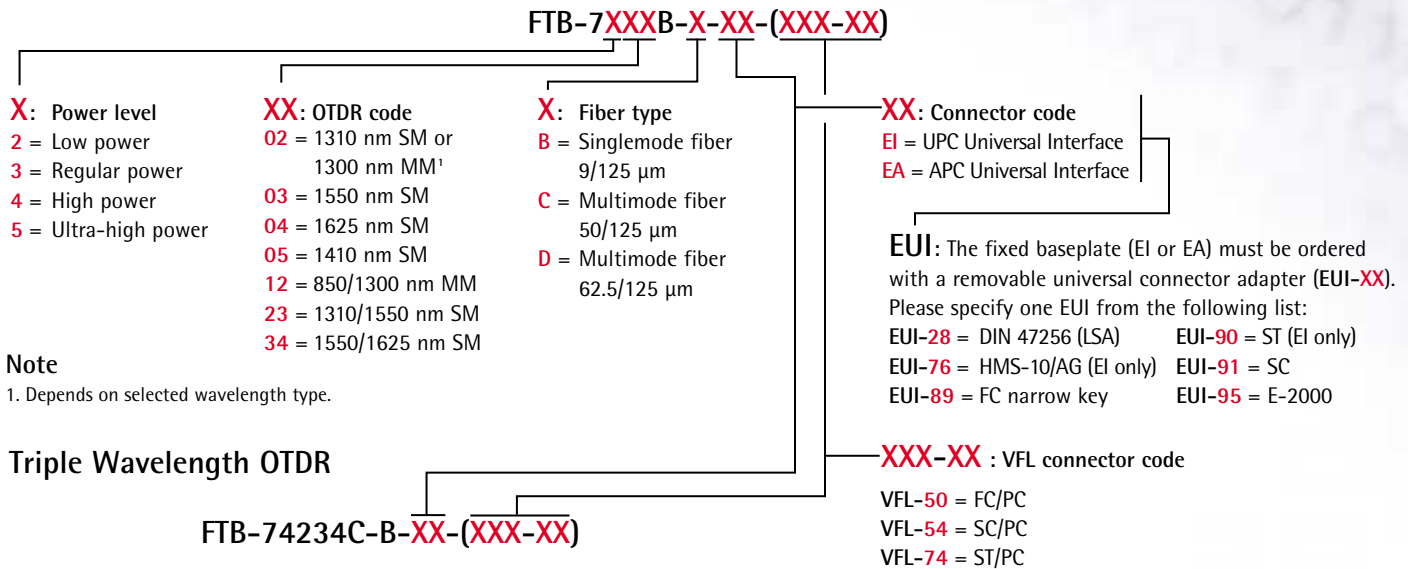

High power OTDR (1310/1550/1625) for single mode fiber.

FTB-100B Mini-OTDR Kits

Kit/System	Description
TK100B-PP-MM-MM	FTB-100B-OTDR Kit
Test Kit Platform	Description
P5-ZZ	FTB-100B-N4-ZZ, modular mainframe unit, 18.8 cm (7.4 in) monochrome touchscreen display, 32 MB RAM
P6-ZZ	FTB-100B-N4-D2-ZZ, modular mainframe unit, 19.6 cm (7.7 in) color touchscreen display, 32 MB RAM
P7-ZZ-XX	FTB-100B-N4-PM-ZZ, modular mainframe unit (1 module capacity), 18.8 cm (7.4 in) monochrome touchscreen display (transflective), 32 MB RAM with power meter InGaAs detector
P8-ZZ-XX	FTB-100B-N4-D2-PM-ZZ, modular mainframe unit (1 module capacity), 19.6 cm (7.7 in) color touchscreen display, 32 MB RAM with power meter InGaAs detector
First OTDR Module	Description
D1-XX	FTB-7212B-C-EI-XX MM OTDR Module, 850/1300 nm, 23/27 dB (50/125 μm)
D2-XX	FTB-7212B-D-EI-XX MM OTDR Module, 850/1300 nm, 25/29 dB (62.5/125 μm)
D3-XX	FTB-7223B-B-EI-XX SM OTDR Module, 1310/1550 nm, 32/31 dB (9/125 μm)
D4-XX	FTB-7323B-B-EI-XX SM OTDR Module, 1310/1550 nm, 37.5/35.5 dB (9/125 μm)
D5-XX	FTB-7423B-B-EI-XX SM OTDR Module, 1310/1550 nm, 40/38 dB (9/125 μm)
D6-XX	FTB-7434B-B-EI-XX SM OTDR Module, 1550/1625 nm, 40/38 dB (9/125 μm)
D7-XX	FTB-7523B-B-EI-XX SM OTDR Module, 1310/1550 nm, 45/43 dB (9/125 μm)
D8-XX	FTB-7534B-B-EI-XX SM OTDR Module, 1550/1625 nm, 42/40 dB (9/125 μm)
D9-XX	FTB-7334B-B-EI-XX SM OTDR Module, 1550/1625 nm, 35.5/35 dB
D10-XX	FTB-74234C-B-EI-XX SM OTDR Module, 1310/1550/1625 nm, 41/39/38 dB
Second OTDR Module	Description
F1-XX	FTB-7212B-C-EI-XX MM OTDR Module, 850/1300 nm, 23/27 dB (50/125 μm)
F2-XX	FTB-7212B-D-EI-XX MM OTDR Module 850/1300 nm, 25/29 dB (62.5/125 μm)
F3-XX	FTB-7404B-B-EI-XX SM OTDR Module, 1625 nm, 38 dB (9/125 μm)
F4-XX	FTB-7504B-B-EI-XX SM OTDR Module, 1625 nm, 40 dB (9/125 μm)

Notes

PP: Platform code available below
Z: Replace Z with specified language:
GA = English, French, Spanish,
German, Italian, Czech and Russian
GB = Traditional Chinese and GA
GC = Simplified Chinese and GA
MM: OTDR module code
Please specify connector type for each OTDR module (singlemode, multimode).

CORPORATE HEADQUARTERS	400 Godin Avenue	Vanier (Quebec) G1M 2K2 CANADA	Tel.: 1 418 683-0211 · Fax: 1 418 683-2170
EXFO AMERICA	4275 Kellway Circle, Suite 122	Addison TX 75001 USA	Tel.: 1 800 663-3936 · Fax: 1 972 836-0164
EXFO EUROPE	Le Dynasteur, 10/12 rue Andras Beck	92366 Meudon la Forêt Cedex FRANCE	Tel.: +33.1.40.83.85.85 · Fax: +33.1.40.83.04.42
EXFO ASIA-PACIFIC	151 Chin Swee Road, #03-29 Manhattan House	SINGAPORE 169876	Tel.: +65 6333 8241 · Fax: +65 6333 8242
EXFO CHINA	Beijing New Century Hotel Office Tower, Room 1754-1755 No. 6 Southern Capital Gym Road	Beijing 100044 P. R. China	Tel.: +86 (10) 6849 2738 · Fax: +86 (10) 6849 2662
TOLL-FREE (USA and Canada)	Tel.: 1 800 663-3936		www.exfo.com • info@exfo.com

EXFO is certified ISO 9001 and attests to the quality of these products. This device complies with Part 15 of the FCC Rules. Operation is subject to the following two conditions: (1) this device may not cause harmful interference, and (2) this device must accept any interference received, including interference that may cause undesired operation. EXFO has made every effort to ensure that the information contained in this specification sheet is accurate. However, we accept no responsibility for any errors or omissions, and we reserve the right to modify design, characteristics and products at any time without obligation. Units of measurement in this document conform to SI standards and practices.

Contact EXFO for prices and availability or to obtain the phone number of your local EXFO distributor.
For the most recent version of this spec sheet, please go to the EXFO website at <http://www.exfo.com/support/techdocs.asp>
In case of discrepancy, the Web version takes precedence over any printed literature.

