



ABN 43 064 478 842

231 Osborne Avenue Clayton South, VIC 3169  
PO Box 1548, Clayton South, VIC 3169  
t 03 9265 7400 f 03 9558 0875  
freecall 1800 680 680  
www.tmgtestequipment.com.au

## Test & Measurement

- > sales
- > rentals
- > calibration
- > repair
- > disposal

## Complimentary Reference Material

This PDF has been made available as a complimentary service for you to assist in evaluating this model for your testing requirements.

TMG offers a wide range of test equipment solutions, from renting short to long term, buying refurbished and purchasing new. Financing options, such as Financial Rental, and Leasing are also available on application.

TMG will assist if you are unsure whether this model will suit your requirements.

Call TMG if you need to organise repair and/or calibrate your unit.

If you click on the "Click-to-Call" logo below, you can call us for FREE!

TMG Corporate Website

TMG Products Website



Click-to-Call  
TMG Now



Product Lifecycle Management System

### Disclaimer:

All trademarks appearing within this PDF are trademarks of their respective owners.





Version  
01.00

September  
2007

## R&S® ATSI100 Infotainment Test System

Fast, comprehensive tests in automobile production

- ◆ Modular concept
- ◆ Remote control via LAN
- ◆ Wide range of modern signal standards
- ◆ RF power amplification
- ◆ Selftest routines and monitoring of radiated signals
- ◆ Software packages for module and system configuration
- ◆ Interface for process control systems
- ◆ Hot-swapping capability
- ◆ Future-proof and economic enhancement



**ROHDE & SCHWARZ**

## Modular concept for flexible installation

The R&S® ATSI100 system generates every test signal separately in application-specific modules. Each module contains all components needed for signal generation and amplification.

Due to the robust design the modules meet the rigorous standards in automobile production. The R&S® ATSI100 module frames provide easy slot-in installation and power supply for up to two and up to eleven modules, respectively (see Fig. 1).

The modular concept allows the installation of the modules close to the test environment (e.g. test cabin, production line). This largely avoids time-consuming and fault-prone laying of RF cables in the production area.

## Remote control via LAN

Every R&S® ATSI100 module is equipped with an Ethernet LAN interface. The modules can therefore be installed exactly where the individual test signals are needed – and still be remote-controlled and monitored from a central control PC via a standard LAN connection.

This ideally meets the requirements of the automobile industry.

## Testing at all stages of production

Different test strategies at all stages of the production process are supported:

- ◆ Component pretesting by the supplier ("100% strategy")
- ◆ Conventional testing of the finished vehicle on the assembly line or in the test chamber

## Test signals for all purposes

The R&S® ATSI100 covers a wide range of modern standards used in infotainment:

- ◆ AM, FM generator
- ◆ DAB, DMB<sup>1</sup> repeater
- ◆ PAL/NTSC TV generator
- ◆ DVB-T, DVB-H<sup>1</sup>, ATSC<sup>1</sup> repeater
- ◆ GSM/CDMA/WCDMA test
- ◆ GPS repeater
- ◆ Loudspeaker test
- ◆ Audio analysis
- ◆ Keyless entry test (ISM)
- ◆ Tire pressure measurement test<sup>1</sup>
- ◆ Monitoring with sensor antennas

<sup>1</sup> To be supported in the near future.

- ◆ Testing of vehicle modules prior to installation (e.g. loudspeakers in the door module, keyless entry, TPMS)
- ◆ Mobile testing with handheld measuring equipment via radio interface



Fig. 1: Different R&S® ATSI100 modules in the R&S® ATSI100 module frame

## Onboard power amplification

The RF power amplification included in every module ensures high output levels. As there is no need for additional external amplifiers, antennas can be connected directly to the module.

## Selftest functionality

Monitoring is very important for reliable testing. Therefore, the internal operating state of each module is permanently checked by selftest routines. Malfunctions are reported to the system controller via the LAN connection.

## Radiated signal survey

In addition to continuous internal self-testing, all radiated test signals are analyzed on the air interface using the R&S® ATSI100 monitor module and sensor antennas. Any RF level variation can instantly be detected and compensated by readjusting the output level of the affected module. This closed-loop control ensures the integrity of the entire system.

## Module configuration software

As standard, every R&S® ATSI100 module comes with its specific module configuration software. With this intuitive graphical user interface (Figs. 2 and 3), the modules can be operated using a static configuration. Only a Microsoft Windows based PC as well as a LAN connection between the PC and the R&S® ATSI100 module are required.

## Hot-swapping capability

In case of a failure, a defective module can easily be replaced by a spare module without interrupting the rest of the R&S® ATSI100 system. The previous configuration can be written to the new module by the R&S® ATSI100 software.



Fig. 2: R&S® ATSI100 module configuration software (R&S® ATSI100 FM generator)

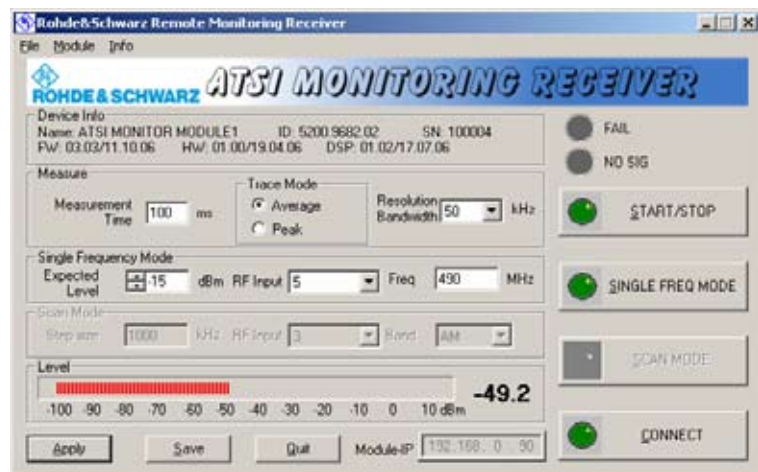

Fig. 3: R&S® ATSI100 module configuration software (R&S® ATSI100 monitor module)

## Interface to process control systems

For easy integration of the R&S® ATSI100 system into the production process control system, the R&S® ATSI-K1 to R&S® ATSI-K8 options offer the appropriate interfaces. These options make it easy for the user to do the following:

- ◆ Program automatic test sequences
- ◆ Interface the master production computer system in customer-specific versions
- ◆ Get a detailed representation of the entire system installed in the production facility
- ◆ Evaluate the modules' selftest and monitoring signals, allowing errors to be instantly located
- ◆ Notify the system administrator by e-mail if an error occurs
- ◆ Analyze complex test scenarios (e.g. loudspeaker and mobile communications test, audio analysis)
- ◆ Configure data management for test scenarios and test parameters depending on different vehicle variants
- ◆ Connect to a common database for extremely flexible test parameter handling

## Future-proof and economic enhancement

Upcoming broadcasting standards can be easily integrated into the infotainment test by adding a specific function module.

As a quality assurance system, the R&S® ATSI100 can provide identical test conditions and thus yield comparable test results on different production lines and at different sites.

## R&S® ATSI-K1 sequence controller

### Application

- ◆ Easy generation of test cases
- ◆ Scheduling of different test cases (e.g. start, a GPS test in parallel with an FM test, followed by an AM test, etc)
- ◆ Repeatable tests

## Introduction

Complex tests (e.g. during final production verification) demand diverse signal sources with changing configurations.

The R&S® ATSI-K1 sequence controller makes it easy to set up the desired sequences using configuration files. It is thus the central component for automating the R&S® ATSI100 test system.

Comparable test results are needed for evaluation and statistics. In this context, the R&S® ATSI-K1 sequence controller is indispensable for easy system automation.

## Specification

- ◆ Requires R&S® ATSI-K8
- ◆ Runs under Microsoft Windows XP or 2000



*Fig. 4: Automobile production line – one field of application of the R&S® ATSI100 test system*

## R&S®ATSI-K2 remote interface

### Application

- ◆ Command exchange with master process control system
- ◆ Database interface
- ◆ Already implemented for leading manufacturers

This ensures optimal test performance and 100% adaptation to the individual car configurations stored in the client's database.

Remote commands of major process control system suppliers (e.g. Siemens) are interpreted.

### Introduction

Infotainment tests in automotive productions must be as fast as possible.

By means of the R&S®ATSI-K2 remote interface, the R&S®ATSI100 system is completely integrated into the customer's process control system (as a slave).

### Specification

- ◆ Requires R&S®ATSI-K8
- ◆ Runs under Microsoft Windows XP or 2000

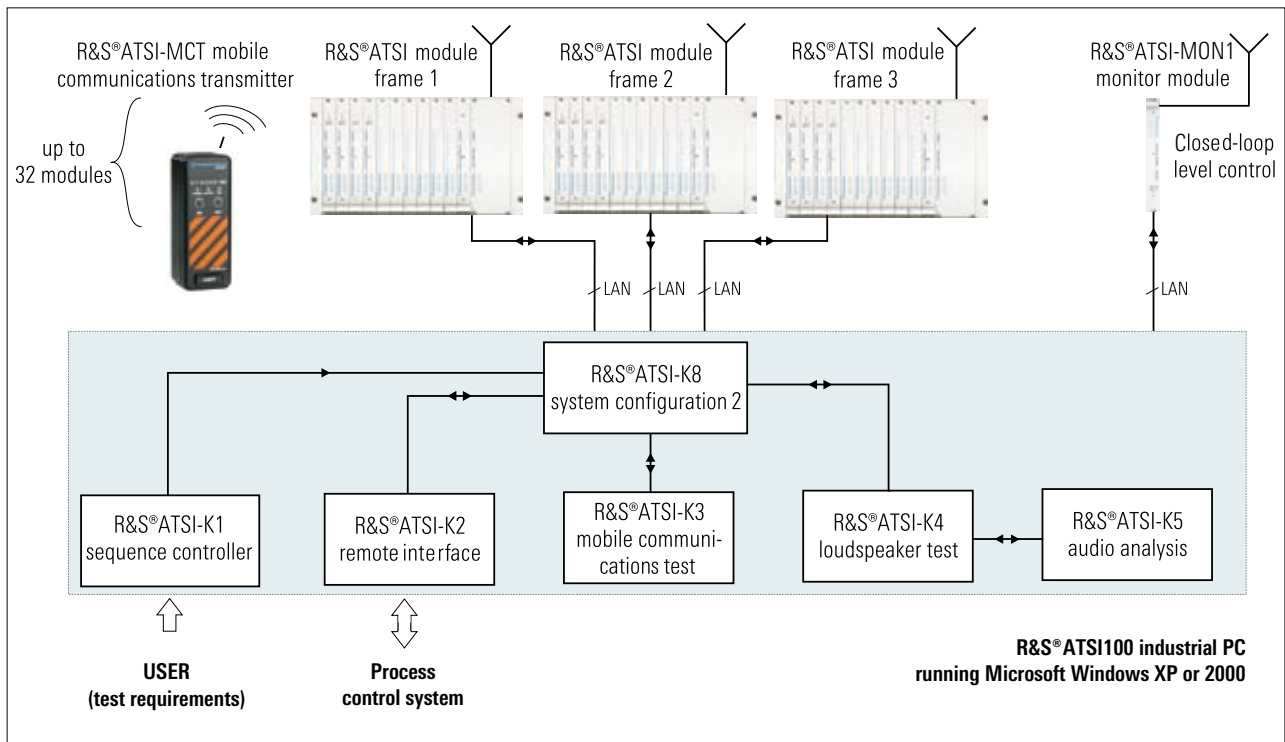

Fig. 5: Block diagram of an all-embracing R&S®ATSI100 test configuration

## R&S®ATSI-K3 mobile communications test software

### Application

- ◆ Test of mobile phone mounts in vehicles (cabling, power supply, antenna, RF level analysis for hopping frequency signals)
- ◆ Configuration of the R&S®ATSI100 mobile communications test hardware (hopping sequences, frequencies, RF levels)
- ◆ Identification of different hopping sequences (up to five TX modules can be used with one RX module)

### Introduction

Car manufacturers offer a mobile phone mount that consists of a uniform backplane (generally installed at the center console) with a mobile-phone-specific adapter cradle.

Besides the R&S®ATSI-K3 software, the R&S®ATSI100 mobile communications test facility includes **two hardware units**:

- ◆ The R&S®ATSI-MCT **mobile communications transmitter** is small and portable; it mechanically fits into the above-mentioned backplane and transmits GSM, CDMA, and UMTS data signals
- ◆ The R&S®ATSI-MCR **mobile communications receiver** receives and analyzes the signals emitted by the R&S®ATSI-MCT

The R&S®ATSI-K3 software is the appropriate tool for utilizing the full capacity of the R&S®ATSI100 mobile communications test hardware.

Configuration of the R&S®ATSI-MCT's hopping sequences, frequencies, and RF levels is easy using the R&S®ATSI-K3 software interface.

The R&S®ATSI-K3 software also evaluates the mobile phone power supply and VSWR at the antenna connector of the vehicle under test. The measurement results are encoded in the R&S®ATSI MCT data stream. Up to

five independent R&S®ATSI-MCTs (configured with different hopping sequences) can be combined with one R&S®ATSI-MCR that is controlled by the R&S®ATSI-K3 software.

### Specification

- ◆ Requires the R&S®ATSI-MCR mobile communications receiver and the R&S®ATSI-MCT mobile communications transmitter
- ◆ Fully configurable by R&S®ATSI-K8 combined with R&S®ATSI-K1, in addition remote-controllable by R&S®ATSI-K2
- ◆ One R&S®ATSI-K3 license required per R&S®ATSI-MCR module
- ◆ Up to five R&S®ATSI-MCT can run under a single R&S®ATSI-K3 license

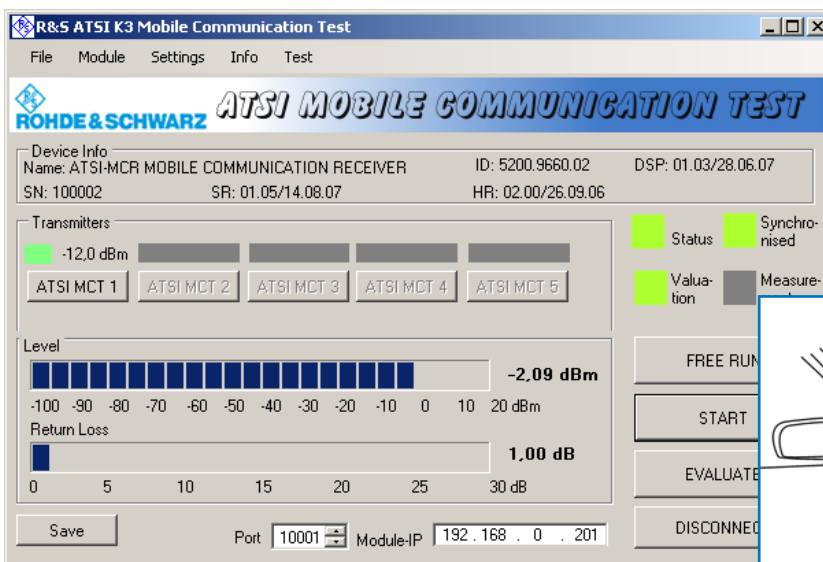

Fig. 6: Graphical interface of the R&S®ATSI-K3 mobile communications test

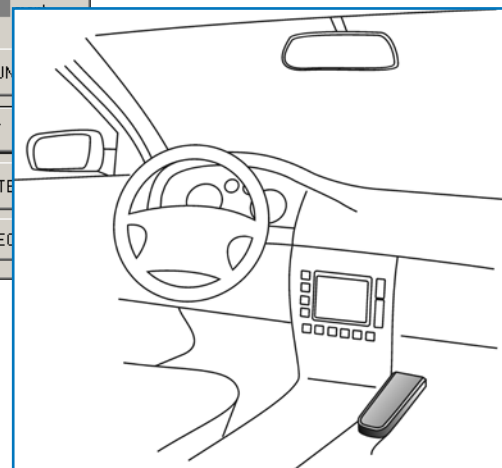

Fig. 7: Mobile phone mount in a vehicle

## R&S®ATSI-K4 loudspeaker test

### Application

- ◆ Testing the correct installation of loudspeakers
- ◆ Frequency-selective measurement of sound pressure level (SPL)
- ◆ Generation of a multisine test signal

### Introduction

The first step to ensure full infotainment functionality is to test the performance of all components that receive and process a radio signal.

The second step is to check the correct reproduction of the processed signals, i.e. the loudspeaker installation in the vehicle.

This is done by placing a radio microphone in the vehicle.

The loudspeakers' sound pressure level at various locations (e.g. front left + right, rear left + right, center) is analyzed.

Failures are exactly located and reported to the customer's process control system.

By controlling fader and balance settings of the car's audio amplifier (via the remote interface of the production system) the loudspeaker test is performed fully automatically.

The reproducible test signal makes troubleshooting easy in the rework area where the revised loudspeaker configuration is verified again.

### Specification

- ◆ Can be launched manually with initial configuration by R&S®ATSI-K7
- ◆ Remotely configurable and manageable with R&S®ATSI-K8 and R&S®ATSI-K1
- ◆ Requires the R&S®ATSI-FM
- ◆ Requires an R&S®ATSI100 PC and a cordless microphone

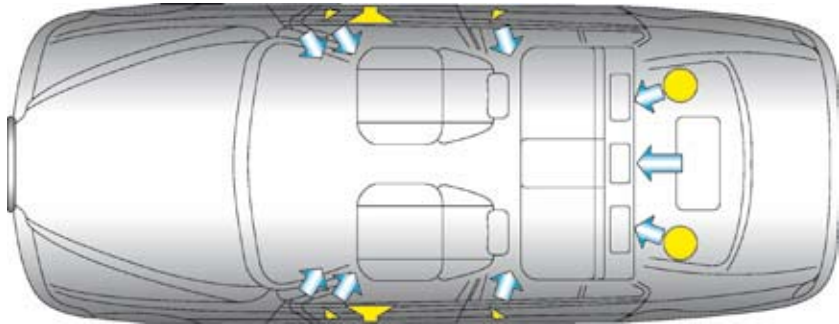

Fig. 8: Position of loudspeakers in a vehicle

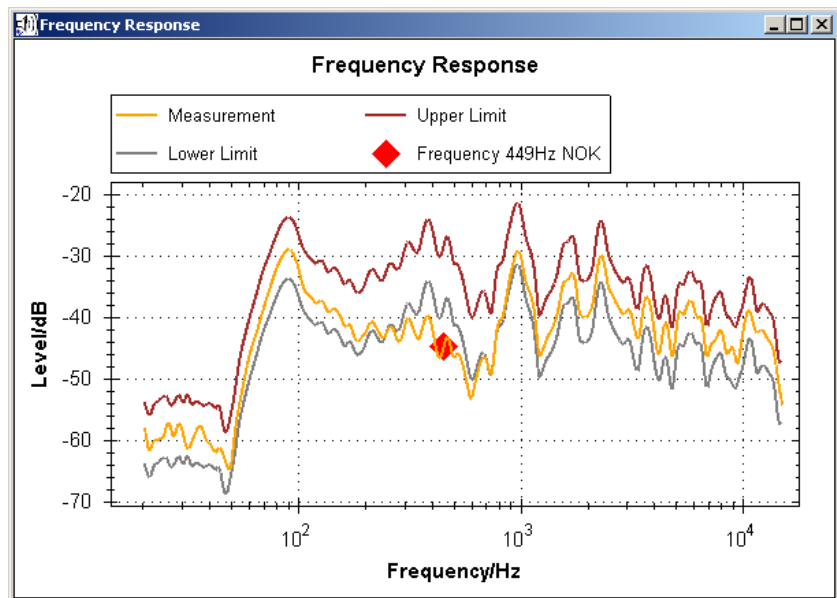

Fig. 9: Lower and upper limits of a frequency response measurement



## R&S® ATSI-K5 audio analysis

### Application

- ◆ Identification of loudspeaker installation errors
- ◆ Detection of mechanical defects in acoustic transducers (rub & buzz detection)
- ◆ Check of the sound system's frequency response
- ◆ Comparison with reference measurements

### Introduction

The R&S® ATSI-K5 audio analysis extends the functionality of the R&S® ATSI100 loudspeaker test (R&S® ATSI-K4) and provides even more advanced testing known as rub & buzz detection.

Using complex FFT algorithms, R&S® ATSI-K5 detects even the slightest mechanical defects in loudspeakers, such as rubbing coils, connecting wires touching the cone, misplaced membrane, excess glue, or air leaks.

Rub & buzz detection is performed prior to the installation of the loudspeaker and in addition to the loudspeaker test (R&S® ATSI-K4) after assembly in the vehicle. The automotive manufacturer can use these test results for process optimization.

### Specification

- ◆ Requires R&S® ATSI-K4
- ◆ Requires the R&S® ATSI-FM module
- ◆ Can be launched manually with initial configuration by R&S® ATSI-K7
- ◆ Remotely configurable and manageable with R&S® ATSI-K8, R&S® ATSI-K1, and R&S® ATSI-K2
- ◆ Requires the R&S® ATSI100 PC or R&S® ATSI100 sound over LAN module and an R&S® ATSI100 cordless microphone

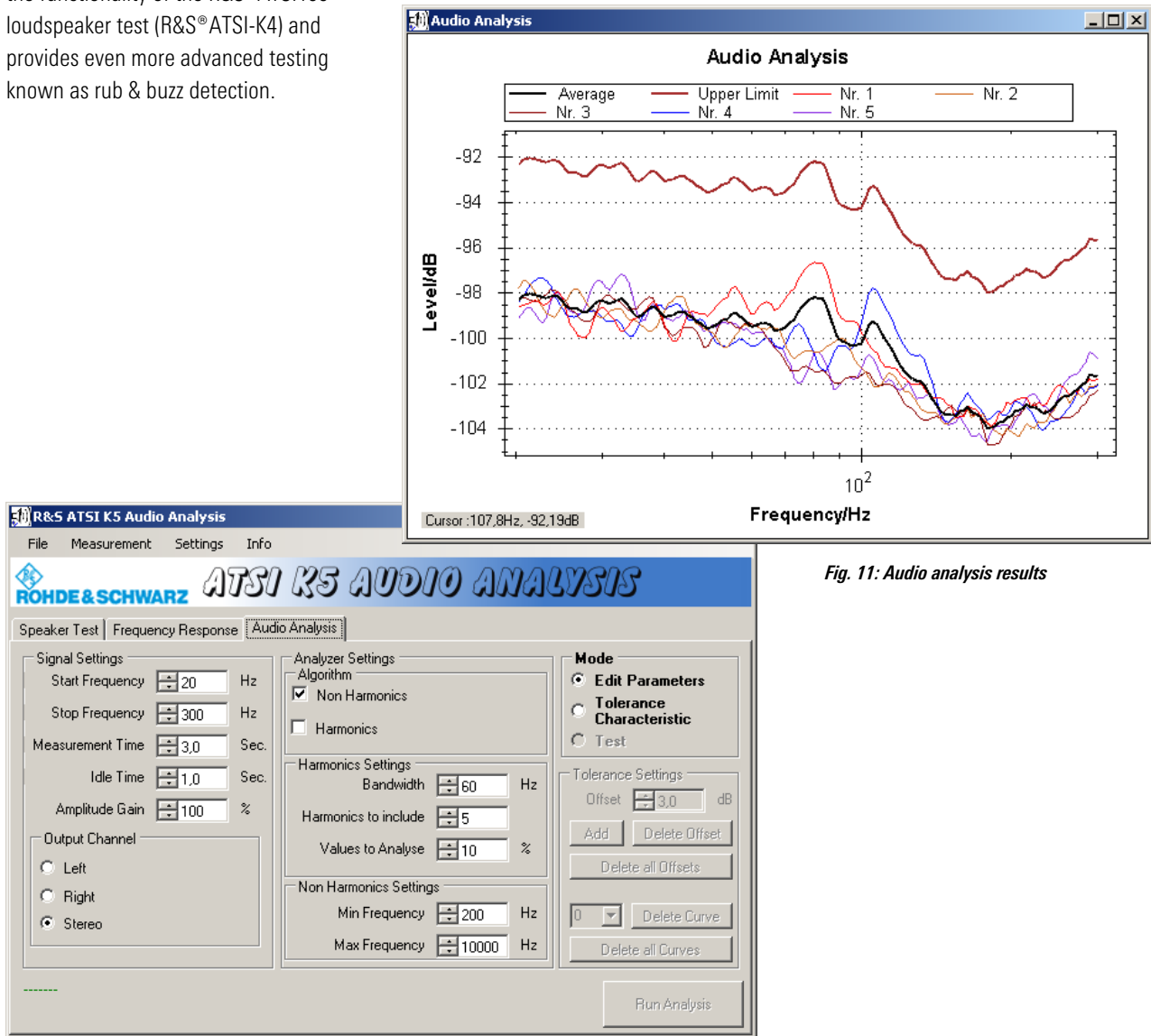

Fig. 11: Audio analysis results

Fig. 10: Setting dialog of R&S® ATSI-K5 audio analysis

# R&S®ATSI-K7 system configuration 1

## Application

- ◆ Easy system overview
- ◆ Shortcuts for launching the configuration software of each installed module
- ◆ Polling and displaying the modules' status information
- ◆ E-mail notification in case of malfunction (configurable)
- ◆ Handling of up to three parameters per module

## Introduction

R&S®ATSI-K7 is ideal for controlling R&S®ATSI100 systems with up to ten modules.

Smaller systems of this kind are often encountered in test facilities at automotive suppliers or in manually operated production tests.

The frontend is easy to use and provides a quick summary of the system's status, using the same LED indication as the modules. The individual test parameterization is accomplished by means of the module configuration software which can be launched by simply clicking the displayed symbol of the module.

Up to three different data sets per module can be stored for individual test procedures. Depending on the modules' status, a notification via e-mail can also be programmed.

## Specification

- ◆ Requires a Microsoft Windows based PC with LAN connection to the respective R&S®ATSI100 modules

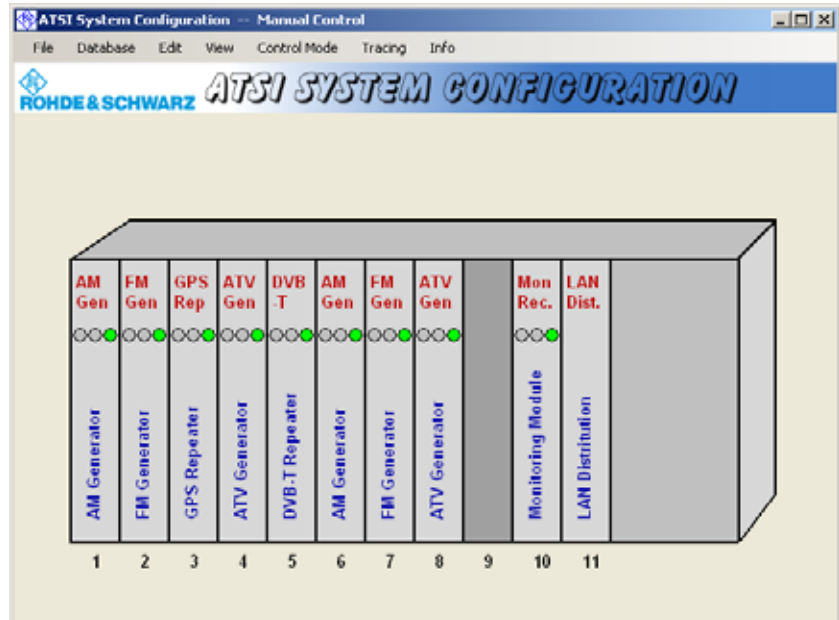

Fig. 12: User interface of R&S®ATSI-K7 system configuration 1

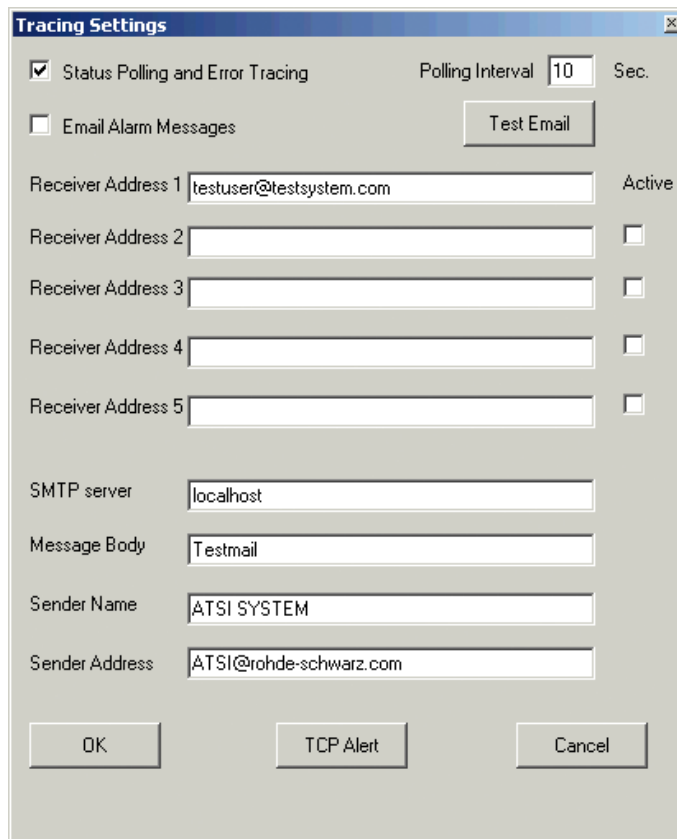

Fig. 13: R&S®ATSI100 system configuration software (e-mail settings)

## R&S®ATSI-K8 system configuration 2

### Application

- ◆ Closed-loop control of all levels (with monitor module installed)
- ◆ Programmable by R&S® ATSI-K1 (sequence controller)
- ◆ Controllable by R&S® ATSI-K2 (remote interface)
- ◆ Handles up to 32 modules and unlimited parameters

### Introduction

The R&S®ATSI-K8 system configuration 2 software is the ultimate tool for comprehensive testing.

The system integrity is ensured by using R&S®ATSI-K8 system configuration 2 in combination with R&S®ATSI-MON1 monitor modules. All transmitted test signals are continuously measured and checked on the air interface by the monitor module. Variations between reference value and measured value are detected by R&S®ATSI-K8. The software tries to readjust the malfunctioning module using remote commands. If the variation cannot be compensated, the user is informed via e-mail and a displayed message. The graphical representation of all signal levels (reference and actual values) is ideal for obtaining an overview of the installation and status of the entire R&S®ATSI100 system.

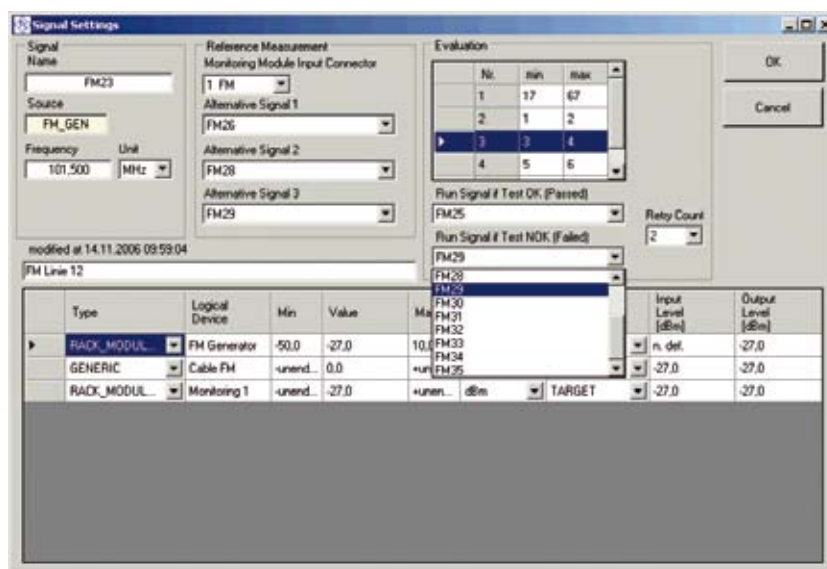

Fig. 14: R&S®ATSI-K8 signal sequencer window

R&S®ATSI-K8 is ideal for integrating the test system into the manufacturer's production control system by means of the R&S®ATSI-K2 remote interface option.

Extremely complex and versatile test scenarios are easy to implement: R&S®ATSI-K8 can be operated by means of the R&S®ATSI-K1 sequence controller.

### Specification

- ◆ Requires a Microsoft Windows based PC with LAN connection to the respective R&S®ATSI100 modules
- ◆ Requires R&S®ATSI-K7

## Overview of modules

Designation	Type	Order No.
AM Generator	R&S® ATSI-AM	5200.8105.02
FM Generator	R&S® ATSI-FM	5200.8111.02
GPS1 Repeater	R&S® ATSI-GPS1	5200.9653.02
ISM Generator	R&S® ATSI-ISM	5200.8128.02
DAB Repeater	R&S® ATSI-DAB1	5200.8134.02
Mobile Communications Transmitter	R&S® ATSI-MCT	5201.6041.02
Mobile Communications Receiver	R&S® ATSI-MCR	5201.6058.02
Analog TV Generator	R&S® ATSI-ATV	5200.9647.02
Monitor Module	R&S® ATSI-MON1	5200.9682.02
DVB-T Repeater	R&S® ATSI-DVBT1	5200.8140.02

## Ordering information

Designation	Type	Order No.
Sequence Controller	R&S® ATSI-K1	5200.9699.02
Remote Interface	R&S® ATSI-K2	5200.9701.02
Mobile Communications Test	R&S® ATSI-K3	5200.9718.02
Loudspeaker Test	R&S® ATSI-K4	5200.9724.02
Audio Analysis	R&S® ATSI-K5	5200.9730.02
System Configuration 1	R&S® ATSI-K7	5201.3042.02
System Configuration 2	R&S® ATSI-K8	5201.3059.02
Database Connection	R&S® ATSI-K9	5201.6958.02



For data sheet, see PD 5213.8909.22  
and [www.rohde-schwarz.com](http://www.rohde-schwarz.com)  
(search term: ATSI100)



**ROHDE & SCHWARZ**

[www.rohde-schwarz.com](http://www.rohde-schwarz.com)

Europe: +49 1805 12 4242, [customersupport@rohde-schwarz.com](mailto:customersupport@rohde-schwarz.com)  
Americas: +1-888-837-8772, [customer.support@rsa.rohde-schwarz.com](mailto:customer.support@rsa.rohde-schwarz.com)  
Asia: +65 65 130 488, [customersupport.asia@rohde-schwarz.com](mailto:customersupport.asia@rohde-schwarz.com)