



ABN 43 064 478 842

231 Osborne Avenue Clayton South, VIC 3169
PO Box 1548, Clayton South, VIC 3169
t 03 9265 7400 f 03 9558 0875
freecall 1800 680 680
www.tmgtestequipment.com.au

Test & Measurement

- > sales
- > rentals
- > calibration
- > repair
- > disposal

Complimentary Reference Material

This PDF has been made available as a complimentary service for you to assist in evaluating this model for your testing requirements.

TMG offers a wide range of test equipment solutions, from renting short to long term, buying refurbished and purchasing new. Financing options, such as Financial Rental, and Leasing are also available on application.

TMG will assist if you are unsure whether this model will suit your requirements.

Call TMG if you need to organise repair and/or calibrate your unit.

If you click on the "Click-to-Call" logo below, you can call us for FREE!

TMG Corporate Website

TMG Products Website



Click-to-Call
TMG Now



Product Lifecycle Management System

Disclaimer:

All trademarks appearing within this PDF are trademarks of their respective owners.



R&S® CMW500 Wideband Radio Communication Tester

Wireless device
production test:
breakthrough in
scalability and speed



75 Years of
Driving
Innovation



R&S®CMW500 Wideband Radio Communication Tester At a glance

The R&S®CMW500 marks the entry of a new generation of test equipment from Rohde & Schwarz. It allows fast and precise production testing of current and future wireless devices from a basic mobile phone to the most sophisticated PDA.

The new tester includes the R&S®Smart Alignment¹⁾ high-speed test concept plus the all-in-one architecture with integrated vector signal generator and analyzer. These are the prerequisites for state-of-the-art non-signaling alignment approaches.

The extreme scalability, test speed, and measurement accuracy of the R&S®CMW500 translate into minimum test costs.

Key facts

- ▀ Base model: general-purpose RF power meter and CW generator with List modes for fast calibration¹⁾ of wireless devices
- ▀ Vector signal analyzer (VSA) for transmitter verification¹⁾
- ▀ Vector signal generator (VSG) for expanded receiver testing: ARB mode¹⁾ for short setup times or online mode¹⁾ for complex signals with high data volume
- ▀ Reference RF power measurement enabled by direct connection of R&S®NRP-Zxx power sensors
- ▀ Easy connection to wireless devices with complex RF architecture by using the integrated RF interface
- ▀ State-of-the-art graphical user interface (GUI)
- ▀ SCPI remote control via LAN/GPIB interface
- ▀ Ready for LXI Class C
- ▀ Process controller with Windows® XP operating system for test routines and remote control via Windows® Remote Desktop

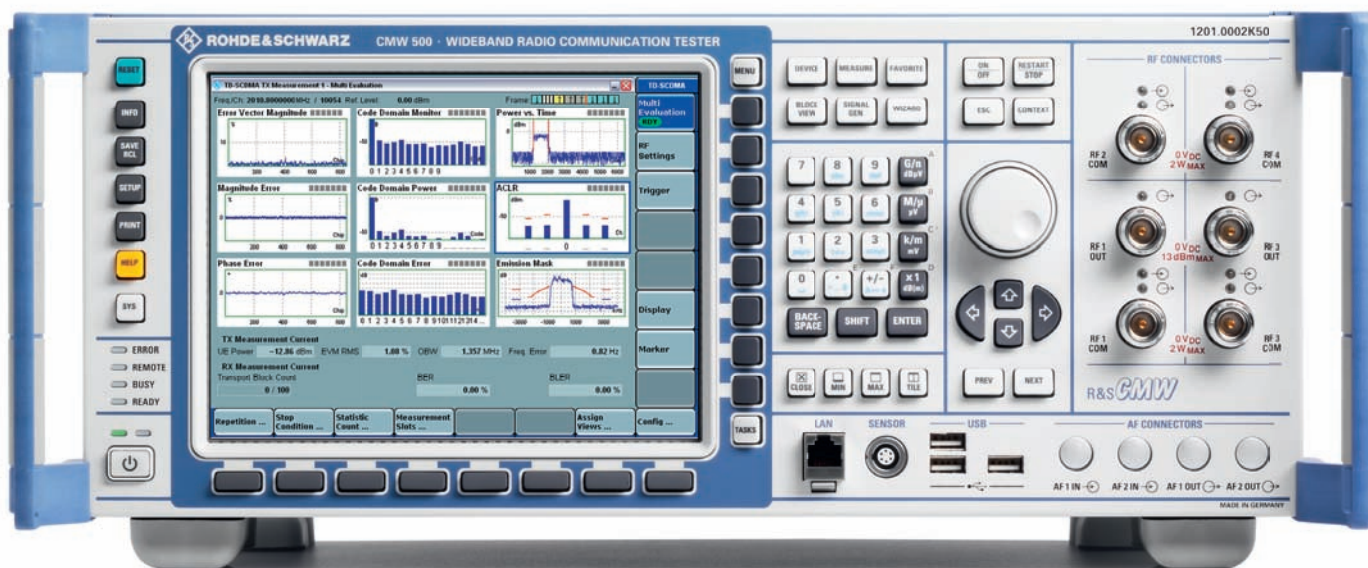

R&S®CMW500 Wideband Radio Communication Tester

Benefits and key features

Multitechnology solution

Technologies: GSM/GPRS/EDGE/WCDMA/HSPA/Mobile WiMAX™²⁾/CDMA2000®³⁾/1xEV-DO/TD-SCDMA/GPS/DVB-T

▷ [page 4](#)

Future-ready RF parameters

3.3/6 GHz frequency range and 40/70 MHz analyzer/generator IF bandwidth

▷ [page 5](#)

Drastically reduced test costs; alignment up to ten times faster

Innovative Rohde&Schwarz test concepts: R&S®Smart Alignment¹⁾ and R&S®Multi-Evaluation List mode¹⁾

▷ [page 6](#)

Designed for high first pass yield

High absolute accuracy plus repeatability and linearity

▷ [page 7](#)

Optimized handling for production test systems

All-in-one architecture¹⁾ with fully automatic RF path correction¹⁾ and Press&Go¹⁾ applications

▷ [page 8](#)

Minimum floor space

Dual-tester configuration enables simultaneous testing of two identical wireless devices

▷ [page 10](#)

Reduced operating costs due to 24-month calibration interval

Optimized solution for every application: selectable calibration interval of 12 or 24 months for high absolute accuracy or reduced costs

▷ [page 12](#)

From pre-sale to service. At your doorstep.

Worldwide network of local Rohde&Schwarz experts in over 70 countries

▷ [page 13](#)

¹⁾ For explanations see glossary at end of brochure.

²⁾ "WiMAX Forum" is a registered trademark of the WiMAX Forum. "WiMAX," the WiMAX Forum logo, "WiMAX Forum Certified," and the WiMAX Forum Certified logo are trademarks of the WiMAX Forum.

³⁾ CDMA2000® is a registered trademark of the Telecommunications Industry Association (TIA -USA).

Multitechnology solution

The R&S®CMW500 allows users to implement the concept of a lean production line from start to finish: A single measuring instrument covers all RF test requirements.

Analyzer

- Flexible RF power meter with List mode for fast calibration of TX power steps (basic function)
- I/Q recorder function for customer-specific evaluation (basic function)
- Vector signal analyzer for TX verification (R&S®CMW-KMxxx measurement personalities)

Generator

- CW generator with List mode for fast RX calibration (basic function)
- Vector signal generator based on ARB + realtime base-band generator board (R&S®CMW-B110A option)
- Online mode: realtime coding of complex signals with high data volume (R&S®CMW-KGxxx generator personalities)
- ARB mode: modulation via precalculated waveforms stored in the ARB memory
- R&S®WinIQSIM2 waveform creation tool supporting different technologies (R&S®CMW-KWxxx options), alternatively user-specific waveforms

Overview of R&S®CMW500 wireless device test functions

Technology	Functionality		
	Vector signal analyzer	Vector signal generator	
		ARB mode	Online mode
GSM/GPRS/EDGE	×	×	×
WCDMA/HSPA	×	×	×
Mobile WiMAX™	×	×	
CDMA2000® 1xRTT	×	×	
CDMA2000® 1xEV-DO	×	×	
TD-SCDMA	×	×	
GPS		×	
DVB-T		×	

Future-ready RF parameters

Minimum risk due to scalable 3.3 GHz or 6 GHz frequency range

The frequency range of the base model is 70 MHz to 3.3 GHz. Extension to 6 GHz by means of software update (R&S®CMW-KB036 option) and instrument calibration. Quick and easy adaptation to new technologies and bands.

High measurement speed owing to 40 MHz IF bandwidth

Simple one-sweep broadband measurements can be performed. Technologies such as LTE/EUTRA with transmission bandwidths of up to 20 MHz can be handled.

Simplified test system architecture through wide RF level range

- Output level range from -130 dBm to $+8$ dBm (CW, rms)
- Output level dynamic range of 128 dB
- Input level range from -84 dBm to $+34$ dBm (power meter, CW, rms)

The wide dynamic range makes additional external amplifiers or attenuators unnecessary. You can reduce test system costs without having to accept restrictions on reliability or accuracy.



Comprehensive RF frontend eliminates external hardware (dual-tester front panel).

Drastically reduced test costs; alignment up to ten times faster

Ongoing technological innovation and the ever-rising number of bands that must be supported increase the complexity of state-of-the-art wireless devices. The test effort multiplies, and the production costs rise. For these reasons, finding new, time-saving alignment approaches is essential. Rohde&Schwarz offers a significant reduction of test times compared to conventional methods by means of R&S®Multi-Evaluation¹⁾ TX measurements and its R&S®Smart Alignment¹⁾ concept. The R&S®CMW500 all-in-one architecture¹⁾ with built-in analyzer and generator provides the fastest possible transmit-receive interaction and is the optimum solution for time-critical tests in production.

R&S®Multi-Evaluation transmitter measurements

- ▮ Different evaluations (power, time mask, modulation quality, spectrum, code domain) can use an identical sampling data set
- ▮ Time-overlapped data capturing and evaluation
- ▮ Enhanced speed by switching off evaluations that are not required

This approach not only increases the test speed in comparison with purely sequential data capturing and evaluation but also ensures greater test depth. This results in a more detailed overview of the transmitter functions, since all measured parameters are correlated.

R&S®Smart Alignment concept

- ▮ Fully automatic frequency and level switching with general-purpose RF generator and power meter in List mode
- ▮ R&S®Multi-Evaluation List mode¹⁾ helps ensure fast transmitter verification
- ▮ Simultaneous transmitter and receiver alignment, if supported by the DUT¹⁾
- ▮ Extensive trigger functions for analyzer/generator
- ▮ Statistical evaluation included

Preconfigured identical test sequences in the DUT¹⁾ and the tester minimize the volume of communications inside the test system, which is the bottleneck of conventional approaches. Flexible R&S®CMW500 parameterization facilitates adaptation to the test philosophy of the wireless device under test and speeds up transfer to mass production.

R&S®Multi-Evaluation: GSM TX measurement.



Designed for high first pass yield

The R&S®CMW500 has been specially designed for production applications: Top priority was placed on accuracy, repeatability, and linearity. These parameters have a direct influence on the production yield. The higher the accuracy of these parameters, the lower the number of DUTs that are classified as faulty although they comply with specifications. Internal temperature sensors automatically adapt the measurement accuracy to the ambient conditions. It is not necessary to perform a calibration when temperatures vary or when the instrument is switched on.

Its high absolute accuracy plus repeatability and linearity enable the R&S®CMW500 to be used flexibly no matter which RF path correction concept is applied to the individual production test station.

Relevant R&S®CMW500 RF power meter parameters

Level uncertainty		<0.50 dB, typ. <0.30 dB
Level repeatability	input level ≥ -40 dBm	typ. <0.01 dB
Level linearity with fixed expected nominal power setting	level range 0 dB to -40 dB	typ. <0.15 dB

Relevant R&S®CMW500 generator parameters

Output level uncertainty	output level > -120 dBm	<0.60 dB, typ. <0.36 dB
Output level repeatability	output level < -80 dBm	typ. <0.05 dB
Output level linearity with fixed RF output attenuator setting	output level range -130 dBm to -5 dBm, GPRF generator List mode, level range 0 dB to -30 dB	typ. <0.15 dB

Optimized handling for production test systems

The R&S®CMW500 is a turnkey solution that can start testing immediately after delivery. The fully integrated tester with calibrated RF paths and Press&Go¹⁾ applications simplifies generating and updating test sequences and production test systems. The all-in-one architecture¹⁾ ensures maximum test performance plus minimum footprint and optimum power consumption. This concept for minimizing test costs comes from a company that has been successfully supplying solutions for the production of wireless devices for more than 30 years: Rohde&Schwarz.

Minimum user risk owing to all-in-one architecture

- Built-in vector signal analyzer and generator
- SCPI remote control via LAN or GPIB interface
- Windows® XP operating system
- Remote control via Windows® Remote Desktop
- Connectors for mouse, keyboard, and external monitor
- Internal TCXO or OCXO timebase and 10 MHz reference frequency output
- External reference frequency (alternative)
- Fully automatic RF path correction concept¹⁾ of frequency, temperature, and level in realtime
- Completely calibrated solution
- Completely standard-conforming EMC¹⁾ characteristics
- Matched power supply

The turnkey solution provides assured measurement accuracy without the user's constant attention. Time- and cost-intensive repetitive self-alignment procedures can be omitted.

Block diagram of the R&S®CMW500

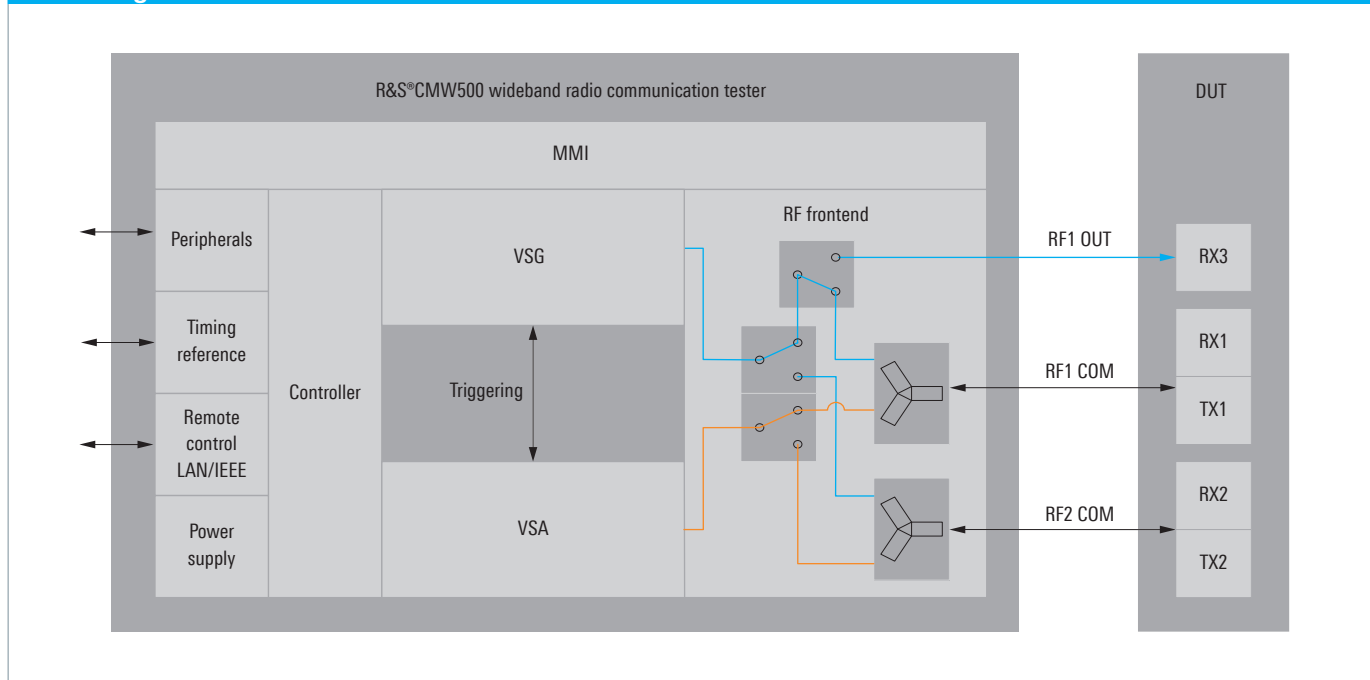

Comprehensive RF frontend eliminating external hardware

- ▮ Flexible RF interface for direct connection of wireless devices with complex RF architecture
- ▮ Alternative: simultaneous connection of two wireless devices with one antenna each (connectors RF1 COM and RF2 COM)
- ▮ Entirely integrated into R&S®CMW500 path correction concept¹⁾
- ▮ Flexible path configuration via GUI¹⁾
- ▮ Optimized for mass tests in production
- ▮ Snap-N female connector RF1 OUT: RF output
- ▮ Snap-N female connector RF1 COM: combined RF input/output
- ▮ Snap-N female connector RF2 COM: combined RF input/output

The handling time for sequential testing of two wireless devices is reduced. The test system costs decrease while reliability and accuracy increase, since additional RF components are not required.

Optimum handling through Press & Go applications

- ▮ Highly automated measurements at the press of a button
- ▮ Preconfigured in line with specifications of the selected technology
- ▮ Extensive statistical evaluations of measurement results already implemented

Technology-specific measurement results are output; no need to bother with time-consuming details such as calculation, limits, or statistics.

Minimum operating costs due to state-of-the-art selftest concept

- ▮ Extensive selftests at the system and module level ensure that the communications between internal modules are not interrupted and that hardware modules work properly
- ▮ Selftests primarily intended for service purposes and not needed during normal operation
- ▮ Examples: voltage diagnostic test, memory test, address line test, download test, EEPROM test

The user can determine the status of the R&S®CMW500 without having to disassemble the test system. The possibility of directly locating error spots in the case of increased DUT¹⁾ failure rates reduces the downtime of the production system.

Precise reference measurements by connecting R&S®NRP-Zxx power sensors

Highly accurate RF power measurements at any point in the test setup make it possible to optimize test procedures in production. It is possible to connect an R&S®NRP-Zxx power sensor directly to the R&S®CMW500 for reference measurements.

Test setup for reference measurements with an R&S®NRP-Zxx power sensor and an R&S®NGMO2 power supply.



Minimum floor space

The R&S®CMW500 can optionally be configured as a dual tester. This configuration includes dual test resources so that two identical wireless devices can be tested simultaneously. This approach saves valuable floor space in the production hall.

Example of dual test setup

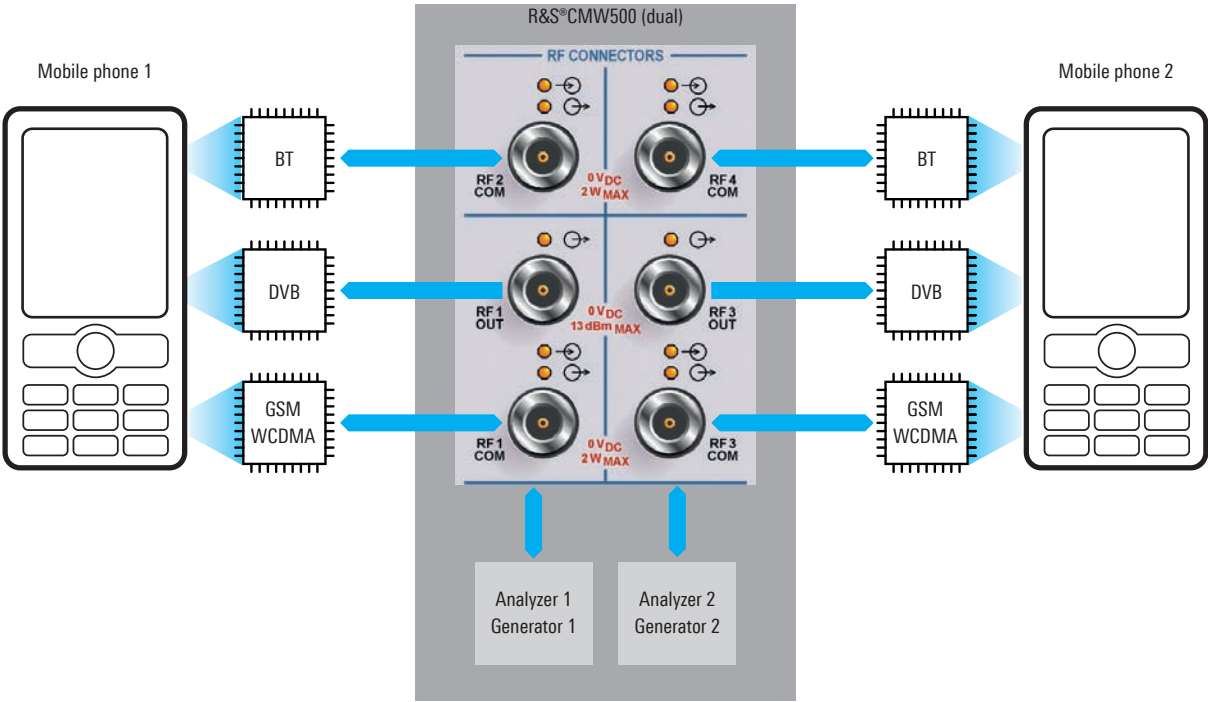

R&S®CMW280 Wideband radio communication tester

The R&S®CMW280 is the compact version of the R&S®CMW500 and has 20% less depth. The instrument can be configured exclusively as a single tester and requires only minimum floor space in classic test concepts.

Differences between R&S®CMW500 and R&S®CMW280		
	R&S®CMW500	R&S®CMW280
Testing capability	1 DUT, optional 2 DUTs simultaneously	1 DUT
Dimensions (W × H × D)	465.1 mm × 197.3 mm × 517.0 mm (18.3 in × 7.8 in × 20.4 in)	465.1 mm × 197.3 mm × 417.0 mm (18.3 in × 7.8 in × 16.4 in)
Weight with typical options	approx. 18 kg (approx. 40 lb)	approx. 14 kg (approx. 31 lb)
Remote control interfaces		
Front panel		
LAN	1	–
Rear panel		
LAN	1	1
IEEE 488	option	–
USB type B	1	–



The R&S®CMW280 is the compact version of the R&S®CMW500 and has 20% less depth.

Reduced operating costs due to 24-month calibration interval

Selectable calibration interval of either 12 or 24 months. Users can optimize costs to achieve high absolute accuracy or minimum test and measurement operating costs.

Relevant R&S®CMW500 RF level uncertainty

12-month calibration interval:

- Analyzer <0.50 dB
- Generator <0.60 dB

24-month calibration interval:

- Analyzer <0.70 dB
- Generator <0.80 dB

R&S®UCS calibration system.



From pre-sale to service. At your doorstep.

The Rohde & Schwarz network in over 70 countries ensures optimum on-site support by highly qualified experts. The user risks are reduced to a minimum at all stages of the project:

- Solution finding/purchase
- Technical start-up/application development/integration
- Training
- Operation/calibration/repair

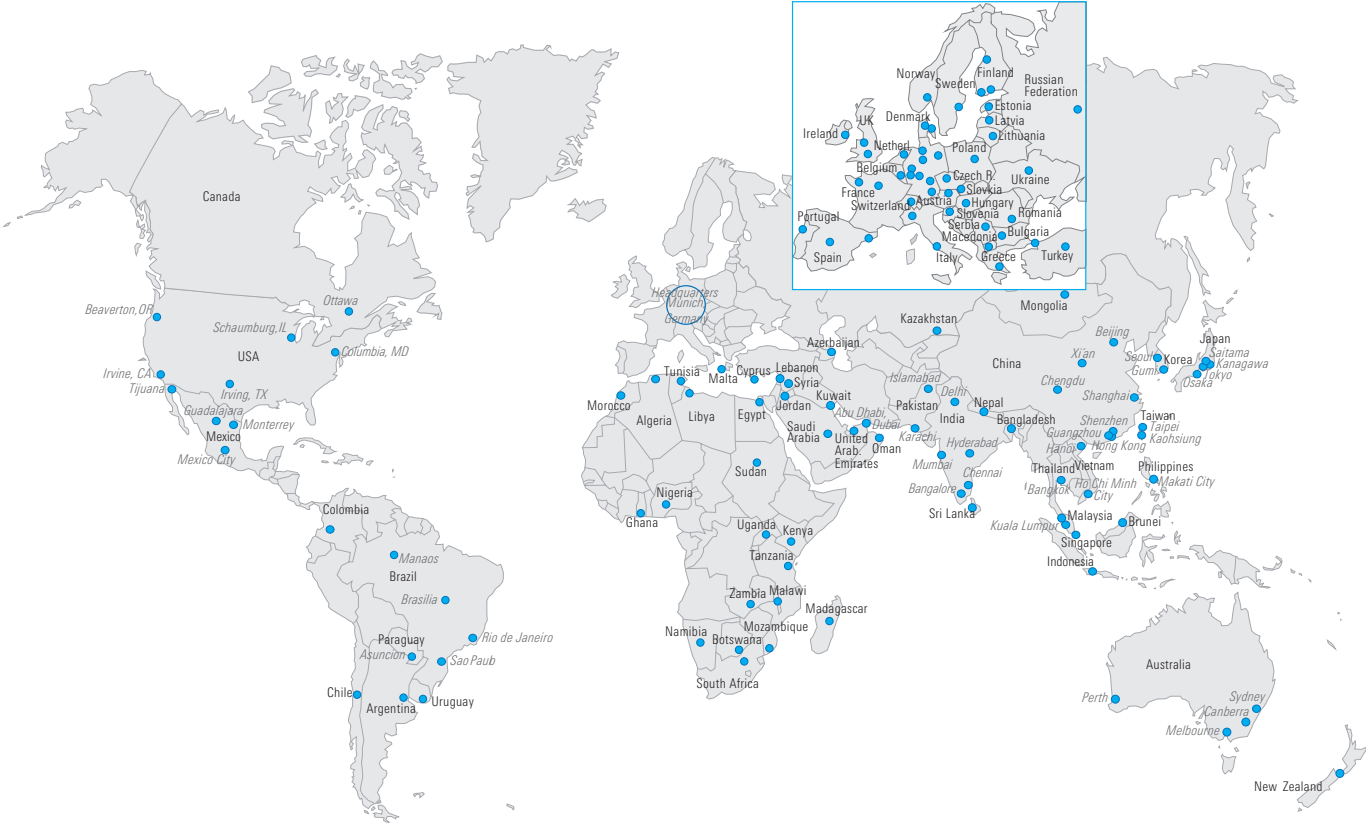

Application

Production test on wireless devices with the R&S®CMW500

Economically produced RF chips exhibit variations in frequency and level characteristics. The following test procedure must be applied:

Step1: Calibration. Deviations from the ideal values for transmitter and receiver must be measured, interpolated, and stored in correction tables.

Step 2: Verification of the most important transmit and receive parameters.

This is the only way to ensure that the specifications of the relevant technology standard will be complied with later during operation in the network and that the wireless device will operate reliably.

Transmit power step alignment

The R&S®CMW500 GPRF¹⁾ power measurement evaluates a list of power steps at different levels and frequencies and performs statistical evaluation. A wide range of IF filters is available:

- Gaussian filters, selectable bandwidths between 1 kHz and 10 MHz
- Bandpass root raised-cosine (RRC) filters, selectable bandwidths between 1 kHz and 40 MHz, roll-off 0.1
- WCDMA RRC filter (3GPP TS 34.121 specification), 3.84 MHz bandwidth, roll-off = 0.22
- CDMA filter (TIA/EIA/IS-2000.2-A specification), 1.4 MHz bandwidth

Chipset requirements	R&S®CMW500 solution
Narrowband RF signal (CW), variable level and frequency	Basic functionality, GPRF ¹⁾ generator
Broadband RF signal, variable level and frequency	GPRF ¹⁾ generator combined with ARB + realtime ¹⁾ baseband generator module (R&S®CMW-B110A option) in ARB mode ¹⁾ ; broadband modulated waveforms
Complex modulated RF signal with technology-specific channels, variable level and frequency	GPRF ¹⁾ generator combined with ARB + realtime ¹⁾ baseband generator module (R&S®CMW-B110A option) in ARB mode ¹⁾ ; technology-specific waveforms precalculated by means of R&S®WinIQSIM2™ (R&S®CMW-KWxxx option)

The screenshot shows the 'General Purpose RF Generator 1 - Generator' software interface. The 'List Configuration' menu is open, displaying a table of power steps. The 'List Mode' is set to 'On', 'Baseband Mode' is 'ARB', and 'List Section' is 'List Configuration'. The table lists five power steps at 903.000000 MHz with varying levels from -40.00 dBm to -80.00 dBm. The 'GPRF Generator' status is shown as 'ON'.

Frequency	Level (RMS)	Digital Gain	Dwell Time	Mod. On/Off
903.000000 MHz	-40.00 dBm	0.00 dB	500.00000 ms	<input type="checkbox"/>
903.000000 MHz	-50.00 dBm	0.00 dB	500.00000 ms	<input type="checkbox"/>
903.000000 MHz	-60.00 dBm	0.00 dB	500.00000 ms	<input type="checkbox"/>
903.000000 MHz	-70.00 dBm	0.00 dB	500.00000 ms	<input type="checkbox"/>
903.000000 MHz	-80.00 dBm	0.00 dB	500.00000 ms	<input type="checkbox"/>

General-purpose RF generator configuration menu.

Calibration of receiver signal strength indication (RSSI)¹⁾

The R&S®CMW500 enables the following calibration scenarios to be implemented as a function of the specific chipset requirements.

The GPRF¹⁾ generator in List mode can be operated with preconfigured levels and frequencies. The precalculated baseband signal, which is stored in the ARB¹⁾ memory, can be provided with markers that stepwise switch the list of the GPRF¹⁾ generator.

Multisegment waveforms and marker-triggered GPRF¹⁾ generator lists are prerequisites for minimum ARB¹⁾ setup times and fast RSSI¹⁾ calibration scenarios.

Transmitter verification

The R&S®CMW500 makes it possible to perform technology-specific R&S®Multi-Evaluation measurements (R&S®CMW-KMxxx options). The R&S®Multi-Evaluation List mode (R&S®CMW-KM012 option) is a consistent implementation of the R&S®Smart Alignment concept (pre-defined test sequences) for transmitter verification.

Receiver verification

The receiver is checked for technology-specific absolute sensitivity and maximum input level.

This verification is based on a BER test¹⁾ with the R&S®CMW500 being used as the signal source. The ARB + realtime¹⁾ baseband generator module (R&S®CMW-B110A option) provides technology-specific signals with pilot and data channels. Depending on the applicable test requirements, the following solutions are offered:

- ▮ ARB mode¹⁾ based on precalculated R&S®WinIQSIM2™ waveforms (R&S®CMW-KWxxx options) or customer-specific waveforms
- ▮ Online mode¹⁾ for pilot channels and PRBS user data channels with high data volume (R&S®CMW-KGxxx options)

In single-ended BER testing¹⁾, the bit error ratio is evaluated in the DUT or the DUT controller.

In loop BER testing¹⁾, the data stream to be tested is routed back to the tester via the uplink. The R&S®CMW500 operates in non-signaling mode (no base station emulation) and evaluates the bit error ratio of the following channels via postprocessing:

- ▮ GSM Loop C
- ▮ WCDMA RMC 12.2 kbps
- ▮ TD-SCDMA RMC 12.2 kbps

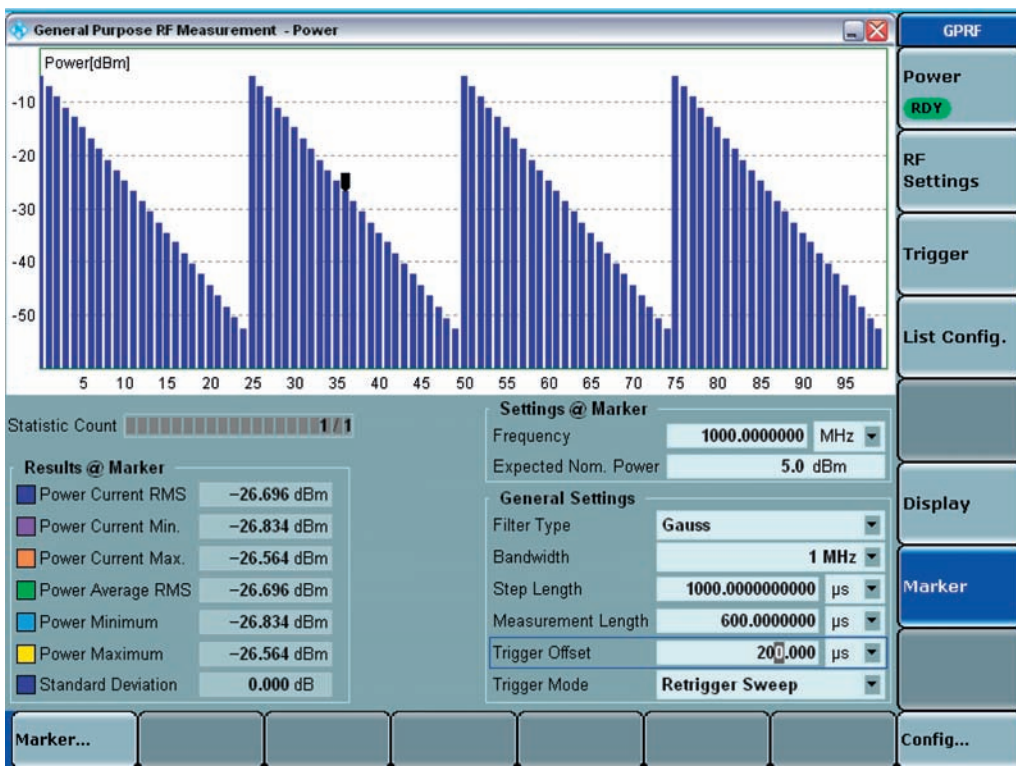

General-purpose RF power measurement menu.

R&S®CMW-KM200 measurement personality⁴⁾

Power

- ▮ Transmit power
- ▮ Time mask

Modulation quality (GMSK modulation scheme)

- ▮ Phase error
- ▮ Frequency error

Modulation quality (8PSK modulation scheme)

- ▮ Error vector magnitude
- ▮ Magnitude error
- ▮ Phase error
- ▮ I/Q errors

Spectral measurement

- ▮ Output RF spectrum modulation
- ▮ Output RF spectrum switching

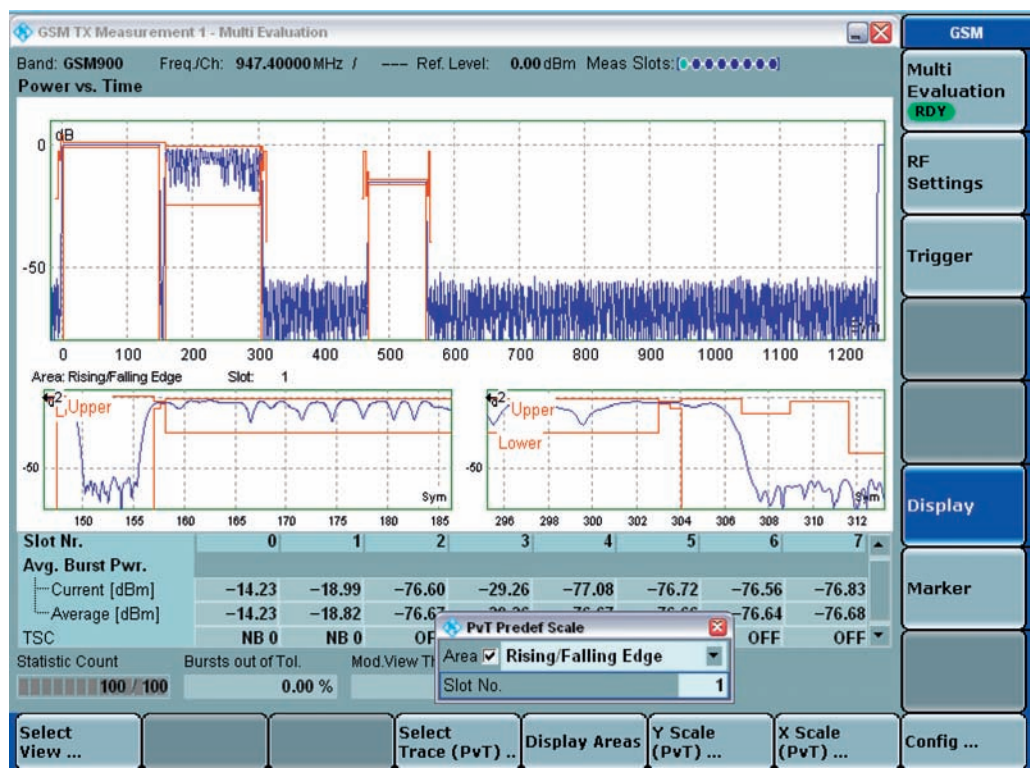

Time mask screen:
GSM/GPRS/EDGE TX measurement – R&S®Multi-Evaluation.

WCDMA

R&S®CMW-KM400 measurement personality⁴⁾

Power

- ▮ OFF power
- ▮ Max. power
- ▮ Min. power
- ▮ UE power versus slot

Modulation quality

- ▮ Error vector magnitude (versus slot and versus chip)
- ▮ Magnitude error (versus slot and versus chip)
- ▮ I/Q origin offset/imbalance versus slot
- ▮ Frequency error versus slot
- ▮ Phase discontinuity

Spectral measurement

- ▮ Adjacent channel leakage ratio
- ▮ Spectrum emission mask
- ▮ Occupied bandwidth

Code domain

- ▮ Code domain power versus slot
- ▮ Peak code domain error
- ▮ Code domain error versus slot
- ▮ Code domain power monitor
- ▮ Code domain error monitor

HSPA extensions

R&S®CMW-KM401 measurement personality

- ▮ Half-slot measurements
- ▮ Modulation analysis of HSPA channels
- ▮ Code domain power measurement of HSPA channels
- ▮ Code domain error versus slot measurement of HSPA channels
- ▮ HS-DPCCH power control
- ▮ Phase discontinuity

⁴⁾ R&S®Multi-Evaluation List mode supported in combination with R&S®CMW-KM012 option.



Overview screen:
WCDMA TX measurement –
R&S®Multi-Evaluation.

CDMA2000[®] 1xRTT

R&S[®]CMW-KM800 measurement personality

Power

- MS power

Modulation quality (OQPSK and HPSK modulation schemes)

- Error vector magnitude
- Magnitude error
- Phase error
- Frequency error
- Carrier feedthrough
- I/Q imbalance
- Waveform quality

Spectral measurement

- Adjacent channel power

Code domain

- Code domain power
- Code domain error power



Overview screen:
CDMA2000[®] 1xRTT
TX measurement –
R&S[®]Multi-Evaluation.

CDMA2000® 1xEV-DO

R&S®CMW-KM880 measurement personality

Power

- MS power

Modulation quality (dual BPSK modulation scheme)

- Error vector magnitude
- Magnitude error
- Phase error
- Frequency error
- Carrier feedthrough
- I/Q imbalance
- Waveform quality

Spectral measurement

- Adjacent channel power

Code domain

- Code domain power
- Code domain error power



Overview screen:
CDMA2000® 1xEV-DO
TX measurement –
R&S®Multi-Evaluation.

Mobile WiMAX™

R&S®CMW-KM700 measurement personality

Power

- ▮ Burst power
- ▮ Crest factor
- ▮ Power versus time

Modulation quality

- ▮ Error vector magnitude
- ▮ I/Q errors
- ▮ Center frequency error

Spectral measurement

- ▮ Adjacent channel power
- ▮ Spectrum emission mask
- ▮ Spectrum flatness
- ▮ Occupied bandwidth

WIMAX - Multi Evaluation

Frequency: 2500.000 MHz Modulation: QPSK Zone Length: 18 FFT: 1024 Bandwidth: 10 MHz

Result Summary	Current	Average	Min	Max
EVM				
EVM All Carriers [dB]	-44.00	-43.60	-44.00	-43.32
EVM Data Carriers [dB]	-42.96	-42.55	-42.96	-42.22
EVM Pilot Carriers [dB]	-47.36	-47.06	-47.36	-46.86
Unmodulated EVM [dB]	---	---	---	---
IQ Offset [dB]	-52.29	-52.49	-52.71	-52.29
Gain Imbalance [dB]	0.00	0.00	-0.01	0.00
Quadrature Error [°]	-0.01	0.00	-0.01	0.01
Center Frequency Error [Hz]	0.46	-0.40	-1.75	0.46
Power				
Burst Power [dBm]	-10.71	-10.72	-10.72	-10.71
Preamble Power [dBm]	---	---	---	---
Subframe Power [dBm]	---	---	---	---
Crest Factor [dB]	9.58	9.60	9.52	9.78
RSSI [dBm]	---	---	---	---
CINR [dB]	---	---	---	---
Occupied Bandwidth [MHz]	9.11	9.11	9.11	9.11
Spectral Flatness				
Outer Lower [dB]	-0.44	-0.44	-0.44	-0.43
Outer Upper [dB]	0.42	0.42	0.41	0.42
Inner Lower [dB]	-0.28	-0.27	-0.28	-0.26
Inner Upper [dB]	0.24	0.24	0.24	0.25
Neighbor [dB]	0.04	0.04	0.03	0.05
Adjacent Channel Power				
Leak Absolute [dBm]	-62.36	-62.24	-62.36	-62.22

WIMAX Meas

Multi Evaluation RDY

RF Settings

Trigger

Display

Repetition ... Statistic Count ... Config ...

Overview screen:
Mobile WiMAX™ TX measurement
– R&S®Multi-Evaluation.

TD-SCDMA

R&S®CMW-KM750 measurement personality

Power

- ▮ UE power
- ▮ Transmit on/off time mask

Modulation quality

- ▮ Error vector magnitude
- ▮ Magnitude error
- ▮ Phase error
- ▮ Frequency error
- ▮ I/Q origin offset
- ▮ I/Q imbalance
- ▮ Waveform quality

Spectral measurement

- ▮ Adjacent channel leakage ratio
- ▮ Spectrum emission mask
- ▮ Occupied bandwidth

Code domain

- ▮ Code domain power
- ▮ Code domain error power
- ▮ Code domain monitor

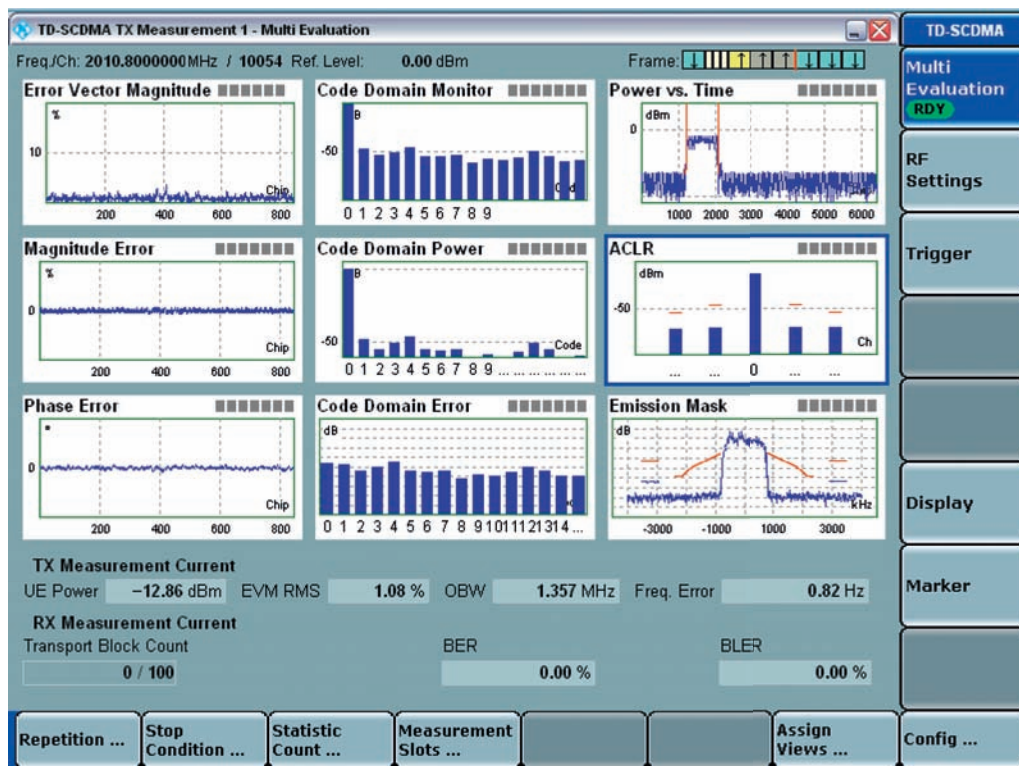

Overview screen:
TD-SCDMA TX measurement –
R&S®Multi-Evaluation.

Recommended extra R&S®CMWrun sequencer software tool

The R&S®CMWrun sequencer software tool meets all needs for executing test sequences to remote-control the R&S®CMW500/280 in R&D, quality assurance, and in the production of current and future wireless equipment.

The software engine is based on the execution of test DLLs (plug-in assemblies). This architecture not only allows easy and straightforward configuration of test sequences without knowledge of specific remote programming of the instrument but also provides full flexibility in configuring parameters and limits of the test items provided in the R&S®CMWrun package options for the different standards.

Highlights

- Multitechnology solution
 - R&S®CMWrun general-purpose software package for non-signaling applications (R&S®CMW-KT051 option)
 - R&S®CMWrun WiMAX® software package for Mobile WiMAX™ in non-signaling and signaling applications (R&S®CMW-KT057 option)
 - Further technologies to be supported in the future
- Ready-to-use solution, containing predefined Rohde&Schwarz applications for the technologies supported by the R&S®CMW500/280
- Application programming interface (API)-based engine for easy and flexible integration of new applications
- Ease of use due to dedicated interfaces for operation, for editing sequences, for measurement reports and for debugging test sequences
- Application for SCPI remote control via LAN or GPIB interface



Key features

Ready-to-use solution for configuring a test sequence with just a few mouse clicks

The straightforward graphical interface makes it easy to program test sequences. The user can define customized test sequences for any of the supported mobile communications standards in the R&S®CMW500/280 with just a few mouse clicks. Programming knowledge is not required.

Test sequence editor for high flexibility, from regression testing to simple test sequences

The R&S®CMWrun sequencer software lets the user integrate basic programming commands such as “if”, “while” or “loop” to control the test sequence, allowing test sequences to be executed interactively. Such control features are integrated into the test sequence in a separate “edit test sequence menu” view to protect the configuration in the standard test sequence view.

Control of all parameters in one view

Input fields are available for configuring all essential RF parameters; tolerances for the individual measurements can be changed. If no special requirements for tolerances exist, the software uses the tolerances defined in the specification. A customer-specific testing scenario can thus be configured very easily.

Automated report options for secure quality management in line with international quality standards

Measurement reports are generated online during test execution or after the end of the test, if priority is placed on measurement speed. In addition, different export formats are available as a global setting or for a specific test sequence. Test reports can be stored automatically after every test routine and automatically exported to a defined report format. This feature allows a high level of automation in production lines, e.g. by providing the interfaces for standard statistical tools.

Flexible optioning concept for instrument- or PC-based licensing

The R&S®CMWrun sequencer software can be installed either on an external PC (Windows® XP PC) or directly on an R&S®CMW500/280. A smart card is required for licensing if the external PC is used for R&S®CMWrun licensing. This allows full flexibility with different instruments. For best performance, the PC installation is recommended.

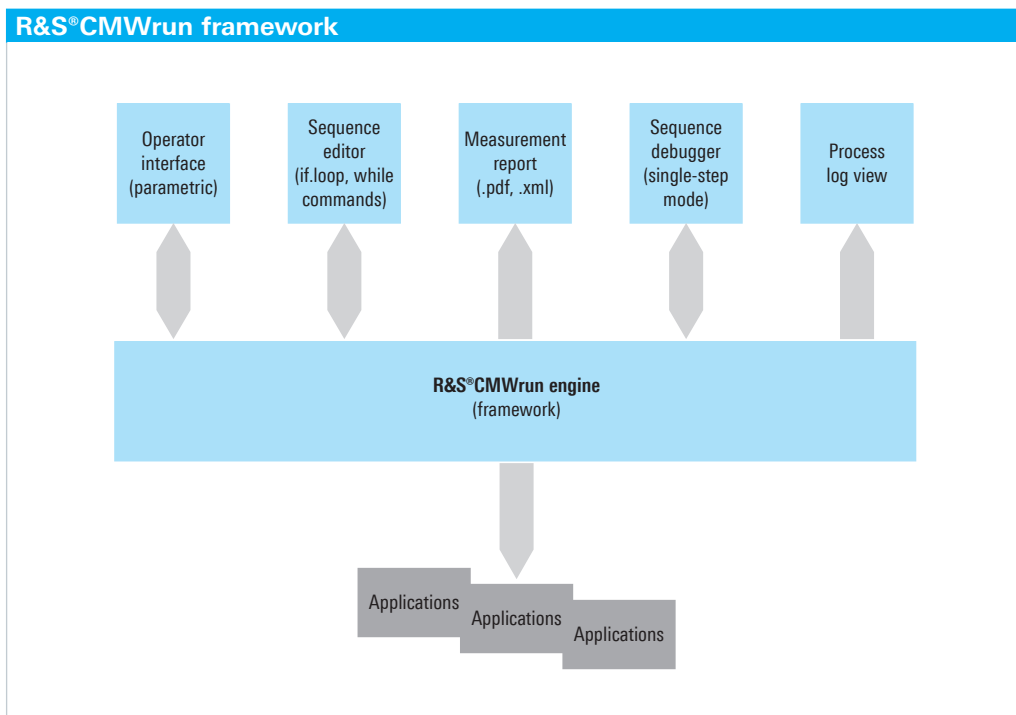

Glossary

Term	Explanation
ACLR	Adjacent channel leakage ratio
ACP	Adjacent channel power
Alignment	Wireless device production cycle consisting of calibration and verification
All-in-one architecture	Complete, highly integrated compact solution with assured measurement accuracy and optimum handling
ARB	Generally used abbreviation for arbitrary waveform generator functionality
ARB generator mode	Baseband generator mode where the modulation is implemented by means of precalculated waveforms stored in the ARB memory
ARB + realtime baseband generator module	Generator module that supports not only the classic ARB mode but also the generation of complex modulated signals in realtime
BB	Baseband
BER	Bit error ratio
Calibration	Wireless device production stage during which the transmit power steps and the RSSI steps are measured and compared to reference values. The correction factors obtained are stored in the wireless device. Other common designations: phasing, tuning, alignment
CW	Continuous wave
DSP	Digital signal processor
Dual tester	Device configuration including two analyzers and two generators each for simultaneous testing of two identical wireless devices
DUT	Device under test
DVI	Digital video interface
EMC	Electromagnetic compatibility
EVM	Error vector magnitude
GPRF	General-purpose radio frequency
GPRF List mode	Lists containing predefined levels and frequencies for GPRF generator/power meter test sequences
GUI	Graphical user interface
HW	Hardware
Loop BER test in non-signaling mode	Method for RX verification in production. This test is performed in non-signaling mode, i.e. without realtime network emulation. The bit error ratio is evaluated through postprocessing via the uplink
ME	Magnitude error
MMI	Man machine interface
OBW	Occupied bandwidth
Online generator mode	Baseband generator mode where complex modulated signals are generated in realtime; maximal operation is performed via MMI
Path correction	Method for increasing the measurement accuracy by taking into account the influence of frequency, temperature, and level on the RF attenuation of the measurement path
PE	Phase error
PRBS	Pseudo random bit sequence
Press&Go	Turnkey, highly automated test functionality that is available at the press of a button
R&S®Multi-Evaluation	Transmitter measurement concept where different measurement parameters use identical raw data
R&S®Smart Alignment	Alignment concept where predefined identical test sequences in the DUT and in the tester reduce the data volume in the test system and significantly shorten the test time
R&S®Multi-Evaluation List mode	R&S®Smart Alignment method; fast TX verification based on predefined test sequences
RF	Radio frequency
RMC	Reference measurement channel
RSSI	Receiver signal strength indication
RX	Receiver
SEM	Spectrum emission mask
Single-ended BER test	Modern approach to receiver verification where the stimulating signal is provided by the measuring instrument and the BER is calculated in the DUT
Single tester	Device configuration including one analyzer and one generator each
SW	Software
Verification	Wireless device production stage during which the most important transmit and receive parameters are checked after calibration
VSA	Vector signal analyzer
VSG	Vector signal generator

R&S®CMW500 specifications in brief

RF generator		
Frequency range	base model	70 MHz to 3300 MHz
	with R&S®CMW-KB036 option	70 MHz to 6000 MHz
Output level range		
RF1 COM, RF2 COM	100 MHz to 3300 MHz	
	continuous wave (CW)	-130 dBm to -5 dBm
	peak envelope power (PEP)	up to -5 dBm
	overranging (PEP)	up to 0 dBm
RF1 OUT	100 MHz to 3300 MHz	
	continuous wave (CW)	-120 dBm to +8 dBm
	peak envelope power (PEP)	up to +8 dBm
	overranging (PEP)	up to +13 dBm
Output level uncertainty		
	in temperature range +20°C to +35°C, no overranging	
RF1 COM, RF2 COM	output level >-120 dBm	
	100 MHz to 3300 MHz	<0.6 dB
RF1 OUT	output level >-110 dBm	
	100 MHz to 3300 MHz	<0.8 dB

Modulation source: arbitrary waveform generator (ARB) (R&S®CMW-B110A option)		
Memory size		1024 Gbyte
Word length	I	16 bit
	Q	16 bit
	marker	4 bit to 16 bit
Sample length	with 4-bit marker	up to 227.55 Msample
Sample rate	minimum	400 Hz
	maximum	100 MHz

RF power meter		
Frequency range	base model	70 MHz to 3300 MHz
	with R&S®CMW-KB036 option	70 MHz to 6000 MHz
Expected nominal power setting range		
RF1 COM, RF2 COM	100 MHz to 3300 MHz	-47 dBm to +34 dBm
Level uncertainty		
RF1 COM, RF2 COM	in temperature range +20°C to +35°C	
	100 MHz to 3300 MHz	<0.5 dB

General data		
Dimensions	W × H × D	465.1 mm × 197.3 mm × 517.0 mm 18.31 in × 7.77 in × 20.35 in (19" 1/1, 4 HU, 450)
Weight	with typical options (single tester)	approx. 18 kg approx. 39.68 lb
Calibration interval	12 months	recommended for highest accuracy, see specified RF generator and RF analyzer level uncertainty
	24 months	add 0.2 dB to specified RF generator and RF analyzer level uncertainty

R&S®CMW500 ordering information

Designation	Type	Order No.
R&S®CMW500 Wideband Radio Communication Tester	R&S®CMW500	1201.0002K50
Mainframe configuration, mandatory		
R&S®CMW500 Wideband Radio Communication Tester, Mainframe, Frequency Range 70 MHz to 3.3 GHz	R&S®CMW-PS502	1202.5408.02
Baseband Interconnection Board (fixed link)	R&S®CMW-S550A	1202.4801.02
RF Frontend Module	R&S®CMW-S590A	1202.5108.02
Selection: Front Panel Without Display/Keypad (contains DVI interface)	R&S®CMW-S600A	1201.0102.02
Selection: Front Panel With Display/Keypad	R&S®CMW-S600B	1201.0102.03
Mainframe configuration, optional		
ARB + Realtime Baseband Generator Module	R&S®CMW-B110A	1202.5508.02
IEEE Bus Interface Module (single connector)	R&S®CMW-B612A	1202.5608.02
IEEE Bus Interface Module (dual connector)	R&S®CMW-B612B	1202.5708.02
Digital Video Interface (DVI) Module (only required for units with display/keypad)	R&S®CMW-B620A	1202.5808.02
Ocxo Module	R&S®CMW-B690A	1202.5908.02
Ocxo Module (highly stable)	R&S®CMW-B690B	1202.6004.02
Frequency Range 3.3 GHz to 6 GHz	R&S®CMW-KB036	1203.0851.02
Mainframe configuration, to be ordered for dual tester, optional		
Baseband Measurement Unit	R&S®CMW-B100A	1202.8607.02
ARB+Realtime Baseband Generator Module	R&S®CMW-B110A	1202.5508.02
RF Converter Module (TRX)	R&S®CMW-B570B	1202.8659.03
RF Frontend Module	R&S®CMW-B590A	1202.8707.02
Frequency Range 3.3 GHz to 6 GHz	R&S®CMW-KB036	1203.0851.02
TX measurement personalities, optional		
FFT Spectrum Analyzer	R&S®CMW-KM010	1203.5953.02
TX Measurement, I/Q versus Slot	R&S®CMW-KM011	1203.0800.02
TX Measurement, R&S®Multi-Evaluation List Mode	R&S®CMW-KM012	1203.4457.02
TX Measurement, GSM/GPRS/EDGE, Uplink	R&S®CMW-KM200	1203.0551.02
TX Measurement, WCDMA, Uplink	R&S®CMW-KM400	1203.0700.02
TX Measurement, WCDMA HSPA Extension, Uplink	R&S®CMW-KM401	1203.2954.02
TX Measurement, Mobile WiMAX™ (IEEE 802.16e)	R&S®CMW-KM700	1202.6604.02
TX Measurement, TD-SCDMA, Uplink	R&S®CMW-KM750	1203.2554.02
TX Measurement, CDMA2000® 1xRTT, Reverse Link	R&S®CMW-KM800	1203.2602.02
TX Measurement, 1xEV-DO, Reverse Link	R&S®CMW-KM880	1203.2854.02
Generator personalities, optional		
Generator, GSM/GPRS/EDGE, Downlink	R&S®CMW-KG200	1203.0500.02
Generator, WCDMA, Downlink	R&S®CMW-KG400	1203.0651.02
Generator, WCDMA HSPA Extension, Downlink	R&S®CMW-KG401	1203.2902.02
Enable R&S®WinIQSIM2™ waveforms, optional		
Enable R&S®WinIQSIM2™ Waveforms, GSM/EDGE	R&S®CMW-KW200	1203.0951.02
Enable R&S®WinIQSIM2™ Waveforms, WCDMA	R&S®CMW-KW400	1203.1006.02
Enable R&S®WinIQSIM2™ Waveforms, WCDMA HSDPA Extension	R&S®CMW-KW401	1203.1058.02
Enable R&S®WinIQSIM2™ Waveforms, WCDMA HSUPA Extension	R&S®CMW-KW402	1203.1106.02
Enable R&S®WinIQSIM2™ Waveforms, GPS	R&S®CMW-KW620	1203.6008.02
Enable R&S®WinIQSIM2™ Waveforms, DVB	R&S®CMW-KW630	1203.6050.02
Enable R&S®WinIQSIM2™ Waveforms, WiMAX® (IEEE 802.16)	R&S®CMW-KW700	1203.1358.02
Enable R&S®WinIQSIM2™ Waveforms, TD-SCDMA	R&S®CMW-KW750	1203.1406.02
Enable R&S®WinIQSIM2™ Waveforms, TD-SCDMA Enhancements	R&S®CMW-KW751	1203.1458.02
Enable R&S®WinIQSIM2™ Waveforms, CDMA2000®	R&S®CMW-KW800	1203.1506.02
Enable R&S®WinIQSIM2™ Waveforms, 1xEV-DO	R&S®CMW-KW880	1203.1558.02

R&S®CMW500 (single) configuration guide

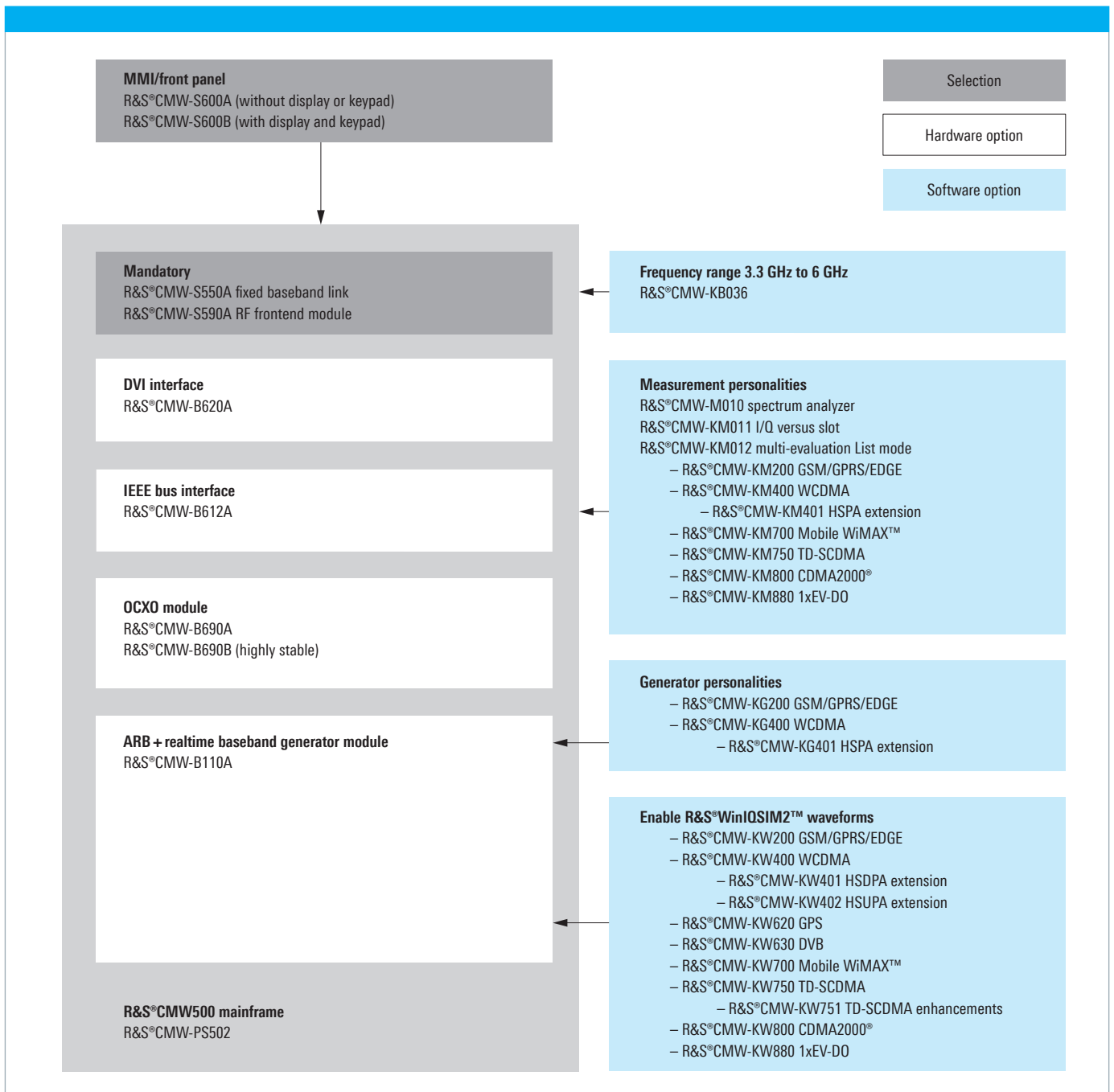

Dual-tester configuration

The mainframe contains one RF converter module (TRX) and one baseband measurement unit (BB Meas). One RF frontend (R&S®CMW-S590A) is mandatory and must be selected. In addition, an RF frontend (R&S®CMW-B590A), an RF converter (R&S®CMW-B570B) and a measurement unit (R&S®CMW-B100A) must be ordered.

Two each of the following products must be ordered:

- Baseband generator module (R&S®CMW-B110A)
- Extended frequency range 3.3 GHz to 6 GHz (R&S®CMW-KB036)
- Software licenses (R&S®CMW-KMxxx TX measurement personalities, R&S®CMW-KGxxx generator personalities, R&S®CMW-KWxxx for R&S®WinIQSIM2™ enabling).

R&S®CMW280 ordering information

Designation	Type	Order No.
R&S®CMW280 Wideband Radio Communication Tester	R&S®CMW280	1201.0002K25
Mainframe configuration, mandatory		
R&S®CMW280 Wideband Radio Communication Tester, Mainframe, Frequency Range 70 MHz to 3.3 GHz	R&S®CMW-PS280	1202.7300.02
RF Frontend Module	R&S®CMW-S590A	1202.5108.02
Frontpanel Without Display/Keypad (contains DVI interface)	R&S®CMW-S600E	1201.0102.06
Frontpanel With Display/Keypad	R&S®CMW-S600F	1201.0102.07
Mainframe configuration, optional		
ARB + Realtime Baseband Generator Module	R&S®CMW-B110A	1202.5508.02
Digital Video Interface (DVI) Module (only required for units with display/keypad)	R&S®CMW-B620A	1202.5808.02
OCXO Module	R&S®CMW-B690A	1202.5908.02
OCXO Module (highly stable)	R&S®CMW-B690B	1202.6004.02
Frequency Range 3.3 GHz to 6 GHz	R&S®CMW-KB036	1203.0851.02
TX measurement personalities, optional		
FFT Spectrum Analyzer	R&S®CMW-KM010	1203.5953.02
TX Measurement, I/Q versus Slot	R&S®CMW-KM011	1203.0800.02
TX Measurement, Multi-Evaluation List Mode	R&S®CMW-KM012	1203.4457.02
TX Measurement, GSM/GPRS/EDGE, Uplink	R&S®CMW-KM200	1203.0551.02
TX Measurement, WCDMA, Uplink	R&S®CMW-KM400	1203.0700.02
TX Measurement, WCDMA HSPA Extension, Uplink	R&S®CMW-KM401	1203.2954.02
TX Measurement, Mobile WiMAX™ (IEEE 802.16e)	R&S®CMW-KM700	1202.6604.02
TX Measurement, TD-SCDMA, Uplink	R&S®CMW-KM750	1203.2554.02
TX Measurement, CDMA2000® 1xRTT, Reverse Link	R&S®CMW-KM800	1203.2602.02
TX Measurement, 1xEV-DO, Reverse Link	R&S®CMW-KM880	1203.2854.02
Generator personalities, optional		
Generator, GSM/GPRS/EDGE, Downlink	R&S®CMW-KG200	1203.0500.02
Generator, WCDMA, Downlink	R&S®CMW-KG400	1203.0651.02
Generator, WCDMA HSPA Extension, Downlink	R&S®CMW-KG401	1203.2902.02
Enable R&S®WinIQSIM2™ waveforms, optional		
Enable R&S®WinIQSIM2™ Waveforms, GSM/EDGE	R&S®CMW-KW200	1203.0951.02
Enable R&S®WinIQSIM2™ Waveforms, WCDMA	R&S®CMW-KW400	1203.1006.02
Enable R&S®WinIQSIM2™ Waveforms, WCDMA HSDPA Extension	R&S®CMW-KW401	1203.1058.02
Enable R&S®WinIQSIM2™ Waveforms, WCDMA HSUPA Extension	R&S®CMW-KW402	1203.1106.02
Enable R&S®WinIQSIM2™ Waveforms, GPS	R&S®CMW-KW620	1203.6008.02
Enable R&S®WinIQSIM2™ Waveforms, DVB	R&S®CMW-KW630	1203.6050.02
Enable R&S®WinIQSIM2™ Waveforms, WiMAX® (IEEE 802.16)	R&S®CMW-KW700	1203.1358.02
Enable R&S®WinIQSIM2™ Waveforms, TD-SCDMA	R&S®CMW-KW750	1203.1406.02
Enable R&S®WinIQSIM2™ Waveforms, TD-SCDMA Enhancements	R&S®CMW-KW751	1203.1458.02
Enable R&S®WinIQSIM2™ Waveforms, CDMA2000®	R&S®CMW-KW800	1203.1506.02
Enable R&S®WinIQSIM2™ Waveforms, 1xEV-DO	R&S®CMW-KW880	1203.1558.02

R&S®CMW280 configuration guide

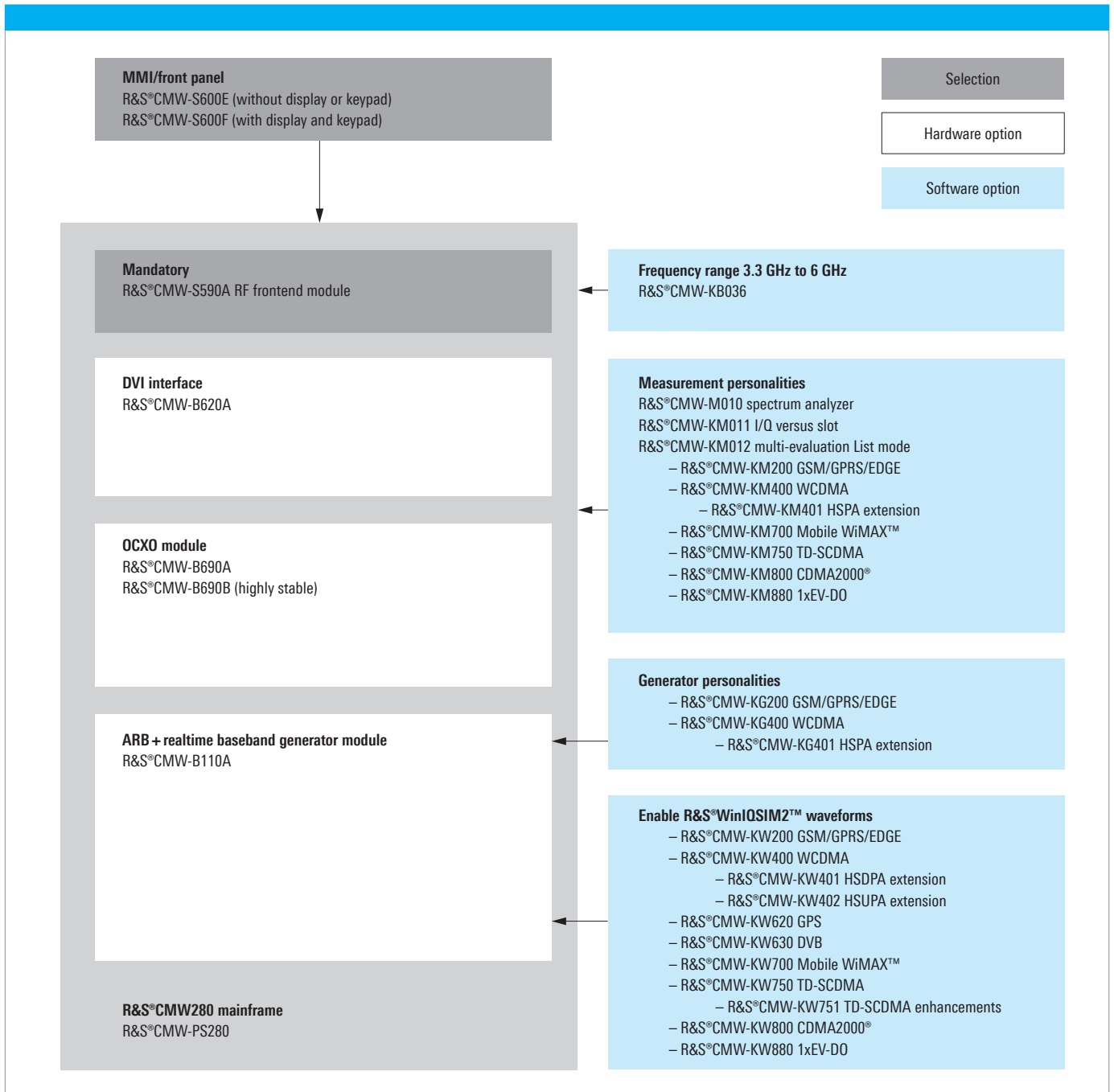

Typical configuration

GSM/EDGE/WCDMA

R&S®CMW280 single tester

Designation	Type	Order No.	Quantity
R&S®CMW280 Wideband Radio Communication Tester	R&S®CMW280	1201.0002K25	1
R&S®CMW280 Wideband Radio Communication Tester, Mainframe, Frequency Range 70 MHz to 3.3 GHz	R&S®CMW-PS280	1202.7300.02	1
Baseband Interconnection Board (fixed link)	R&S®CMW-S550A	1202.4801.02	1
RF Frontend Module	R&S®CMW-S590A	1202.5108.02	1
Selection: Front Panel Without Display/Keypad (contains DVI interface)	R&S®CMW-S600A	1201.0102.02	1
ARB + Realtime Baseband Generator Module	R&S®CMW-B110A	1202.5508.02	1
TX Measurement, GSM/GPRS/EDGE, Uplink	R&S®CMW-KM200	1203.0551.02	1
TX Measurement, WCDMA, Uplink	R&S®CMW-KM400	1203.0700.02	1
Enable R&S®WinIQSIM2™ Waveforms, GSM/EDGE	R&S®CMW-KW200	1203.0951.02	1
Enable R&S®WinIQSIM2™ Waveforms, WCDMA	R&S®CMW-KW400	1203.1006.02	1

R&S®CMW500 single tester

Designation	Type	Order No.	Quantity
R&S®CMW500 Wideband Radio Communication Tester	R&S®CMW500	1201.0002K50	1
R&S®CMW500 Wideband Radio Communication Tester, Mainframe, Frequency Range 70 MHz to 3.3 GHz	R&S®CMW-PS502	1202.5408.02	1
Baseband Interconnection Board (fixed link)	R&S®CMW-S550A	1202.4801.02	1
RF Frontend Module	R&S®CMW-S590A	1202.5108.02	1
Selection: Front Panel Without Display/Keypad (contains DVI interface)	R&S®CMW-S600A	1201.0102.02	1
ARB + Realtime Baseband Generator Module	R&S®CMW-B110A	1202.5508.02	1
TX Measurement, GSM/GPRS/EDGE, Uplink	R&S®CMW-KM200	1203.0551.02	1
TX Measurement, WCDMA, Uplink	R&S®CMW-KM400	1203.0700.02	1
Enable R&S®WinIQSIM2™ Waveforms, GSM/EDGE	R&S®CMW-KW200	1203.0951.02	1
Enable R&S®WinIQSIM2™ Waveforms, WCDMA	R&S®CMW-KW400	1203.1006.02	1

R&S®CMW500 dual tester

Designation	Type	Order No.	Quantity
R&S®CMW500 Wideband Radio Communication Tester	R&S®CMW500	1201.0002K50	1
R&S®CMW500 Wideband Radio Communication Tester, Mainframe, Frequency Range 70 MHz to 3.3 GHz	R&S®CMW-PS502	1202.5408.02	1
Baseband Interconnection Board (fixed link)	R&S®CMW-S550A	1202.4801.02	1
RF Frontend Module	R&S®CMW-S590A	1202.5108.02	1
Selection: Front Panel Without Display/Keypad (contains DVI interface)	R&S®CMW-S600A	1201.0102.02	1
Baseband Measurement Unit	R&S®CMW-B100A	1202.8607.02	1
ARB + Realtime Baseband Generator Module	R&S®CMW-B110A	1202.5508.02	2
RF Converter Module (TRX)	R&S®CMW-B570B	1202.8659.03	1
RF Frontend Module	R&S®CMW-B590A	1202.8707.02	1
TX Measurement, GSM/GPRS/EDGE, Uplink	R&S®CMW-KM200	1203.0551.02	2
TX Measurement, WCDMA, Uplink	R&S®CMW-KM400	1203.0700.02	2
Enable R&S®WinIQSIM2™ Waveforms, GSM/EDGE	R&S®CMW-KW200	1203.0951.02	2
Enable R&S®WinIQSIM2™ Waveforms, WCDMA	R&S®CMW-KW400	1203.1006.02	2

Recommended extras and power sensors

Designation	Type	Order No.
Recommended extras and power sensors		
R&S®CMWrun Sequencer Software Tool, General Purpose	R&S®CMW-KT051	1203.4157.02
R&S®CMWrun Sequencer Software Tool, WiMAX®	R&S®CMW-KT057	1203.4205.02
LC TFT Display, 17", 1280 × 1024, DVI-D and Analog Interface	R&S®PMC3	1082.6004.12
Keyboard with USB Interface (US character set)	R&S®PSL-Z2	1157.6870.04
Mouse with USB Interface (optical, with wheel)	R&S®PSL-Z10	1157.7060.04
19" Adapter, 4 HU, 1/1 for Design2000 Cabinets	R&S®ZZA-411	1096.3283.00
Average Power Sensor for Universal Use, 10 MHz to 18 GHz, 200 pW to 200 mW	R&S®NRP-Z21	1137.6000.02
Power Sensor Module, DC to 18 GHz	R&S®NRP-Z27	1169.4102.02
Level Control Sensor, 10 MHz to 18 GHz for Signal Generators	R&S®NRP-Z28	1170.8008.02
Documentation of Calibration Values	R&S®DCV-2	0240.2193.08

PC-based R&S®CMW applications

Designation	Type	Order No.
PC-based R&S®CMW applications	R&S®CMWPC	1201.0002K90
Mandatory		
USB Smartcard for PC-based R&S®CMW Applications	R&S®CMW-S089A	1202.7900.02
Optional		
R&S®CMWrun Sequencer Software Tool, General Purpose	R&S®CMW-KT051	1203.4157.02
R&S®CMWrun Sequencer Software Tool, WiMAX®	R&S®CMW-KT057	1203.4205.02

System requirements	
Processor	1300 MHz (x86) minimum
Memory	256 MB minimum
HDD space	80 MB minimum
Operating system	Windows® XP, Service Pack 2, 32 bit
Software	Microsoft .net framework 2.0 or later

Note:

Before ordering, the application has to be defined: For instrument-based licensing, the serial number of the R&S®CMW500/280 is required. For PC-based licensing, the serial number of the R&S®CMWPC smart card is required.

Your local Rohde & Schwarz expert will help you to find the solution that is optimally suited to your requirements and will be glad to prepare a custom offer for you.

To find your nearest Rohde & Schwarz representative, visit:
www.sales.rohde-schwarz.com

Service you can rely on

- | In 70 countries
- | Person-to-person
- | Customized and flexible
- | Quality with a warranty
- | No hidden terms

About Rohde & Schwarz

Rohde & Schwarz is an independent group of companies specializing in electronics. It is a leading supplier of solutions in the fields of test and measurement, broadcasting, radiomonitoring and radiolocation, as well as secure communications. Established 75 years ago, Rohde & Schwarz has a global presence and a dedicated service network in over 70 countries. Company headquarters are in Munich, Germany.

Regional contact

Europe, Africa, Middle East

+49 1805 12 42 42* or +49 89 4129 137 74

customersupport@rohde-schwarz.com

North America

1 888 TEST RSA (1 888 837 87 72)

customer.support@rsa.rohde-schwarz.com

Latin America

+1 410 910 79 88

customersupport.la@rohde-schwarz.com

Asia/Pacific

+65 65 13 04 88

customersupport.asia@rohde-schwarz.com

Certified Quality System
ISO 9001
DQS REG. NO 1954 QM

Certified Environmental System
ISO 14001
DQS REG. NO 1954 UM

For data sheet, see
PD 5213.9211.22
and www.rohde-schwarz.com

Rohde & Schwarz GmbH & Co. KG

Mühlldorfstraße 15 | 81671 München

Phone +498941 290 | Fax +498941 29 121 64

www.rohde-schwarz.com

R&S® is a registered trademark of Rohde & Schwarz GmbH & Co. KG
Trade names are trademarks of the owners | Printed in Germany (ch)
PD 5213.9211.12 | Version 03.00 | November 2008 | R&S®CMW500
Data without tolerance limits is not binding | Subject to change

*0.14 €/min within German wireline network; rates may vary in other networks (wireline and mobile) and countries.