



ABN 43 064 478 842

➤ 231 Osborne Avenue Clayton South, VIC 3169  
 PO Box 1548, Clayton South, VIC 3169  
 t 03 9265 7400 f 03 9558 0875  
 freecall 1800 680 680  
 www.tmgtestequipment.com.au

## Test & Measurement

- sales
- rentals
- calibration
- repair
- disposal

## Complimentary Reference Material

This PDF has been made available as a complimentary service for you to assist in evaluating this model for your testing requirements.

TMG offers a wide range of test equipment solutions, from renting short to long term, buying refurbished and purchasing new. Financing options, such as Financial Rental, and Leasing are also available on application.

TMG will assist if you are unsure whether this model will suit your requirements.

Call TMG if you need to organise repair and/or calibrate your unit.

If you click on the “Click-to-Call” logo below, you can call us for FREE!

TMG Corporate Website

TMG Products Website



**Click-to-Call**  
TMG Now



Product Lifecycle Management System

**Disclaimer:**

All trademarks appearing within this PDF are trademarks of their respective owners.



Version  
03.00July  
2004

## Microwave Signal Generators R&S® SMR 50/60

High-performance, cost-effective and reliable up to 60 GHz

- ◆ Extension of the successful R&S® SMR family by two models
  - R&S® SMR 50 (10 MHz to 50 GHz)
  - R&S® SMR 60 (10 MHz to 60 GHz)
- ◆ CW generator with pulse modulation and digital frequency sweep
- ◆ High output level
  - R&S® SMR 50 >0 dBm (50 GHz)
  - R&S® SMR 60 >–4 dBm (60 GHz)
- ◆ Fast quasi-analog ramp sweep
- ◆ Level sweep with a minimum step time of 1 ms
- ◆ Easily upgradeable to AM/FM signal generator and synthesized sweep generator with analog ramp sweep owing to flexible options concept
- ◆ Optional pulse generator for radar and EMC applications
- ◆ Compact, lightweight, user-friendly – ideal in the lab and for field applications
- ◆ 3-year calibration cycle

# The allrounder with future-proof design

## Ease of operation

- ◆ High-contrast LC display
- ◆ Online help including IEC/IEEE-bus commands
- ◆ Simple and self-explanatory settings
- ◆ Storage of menu levels
- ◆ One-hand operation with EasyWheel

## Wide frequency range

- ◆ 1 GHz to 50 GHz (R&S®SMR50)
- ◆ 1 GHz to 60 GHz (R&S®SMR60)
- ◆ Extension of lower frequency limit to 10 MHz (option R&S®SMR-B11)
- ◆ Frequency resolution 1 kHz or 0.1 Hz (option R&S®SMR-B3)

## High output power

- ◆ Without option R&S®SMR-B18
  - R&S®SMR50 >+3 dBm (at 50 GHz)
  - R&S®SMR60 >0 dBm (at 60 GHz)
- ◆ With option R&S®SMR-B18
  - R&S®SMR50 >0 dBm (at 50 GHz)
  - R&S®SMR60 >–4 dBm (at 60 GHz)

## High-precision level control

- ◆ High-precision, frequency-response-compensated level control
- ◆ Setting range extendible to –110 dBm (option R&S®SMR-B18)

## Three instruments in one

- ◆ CW generator with pulse modulation capability (standard version)
- ◆ Signal generator with AM/FM SCAN and LF generator (option R&S®SMR-B5)
- ◆ Synthesized sweep generator with analog ramp sweep (option R&S®SMR-B4)

## Optional pulse generator (R&S®SMR-B14)

- ◆ Operating modes: single pulse, double pulse (automatically or externally triggered), delayed pulse (externally triggered), gate mode (external)
- ◆ Pulse repetition 100 ns to 85 s
- ◆ Pulse width 20 ns to 1 s

## Sweep capabilities

- ◆ Digital RF and level sweep (standard version)
- ◆ Analog ramp sweep (RF sweep, option R&S®SMR-B4)
- ◆ Maximum sweep rate for ramp sweeps at least 600 MHz/ms ( $f > 2$  GHz)
- ◆ Digital sweep of LF generator (with option R&S®SMR-B5)
- ◆ 10 user-selectable frequency markers for RF sweep
- ◆ Operating modes: automatic, single-shot, manual, externally triggered, linear or logarithmic

## Memory

- ◆ Space for 50 complete instrument setups



# CW, signal or synthesized sweep generator

## CW generator

The R&S®SMR50/60 are CW generators with pulse modulation capability and a lower limit frequency of 1 GHz. They cover the range up to 50 GHz (R&S®SMR50) and 60 GHz (R&S®SMR60). The lower limit can be expanded to 10 MHz by the Frequency Extension 0.01 GHz to 1 GHz (option R&S®SMR-B11).

Owing to their excellent price/performance ratio the two models are ideal for economical microwave test setups up to 60 GHz. Should the measurement tasks become more demanding, both models can be upgraded any time by means of options to give an AM/FM signal generator or a synthesized sweep generator featuring fast, fully synthesized, analog ramp sweep.

### Excellent spectral purity

The R&S®SMR50/60 stand out from other generators for their excellent spectral purity. Advanced frequency synthesis makes for low SSB phase noise and high spurious suppression, both of which are for example prerequisites for reliable receiver measurements. Special microwave filters in the output path of the instrument ensure excellent harmonics suppression. This is necessary to obtain unequivocal results in scalar network analysis measurements.

### High-precision output level

Microwave signal generators are frequently used for calibrating test receivers. This task calls for a highly accurate and stable output level settable with high resolution. This is ensured by a high-precision, frequency-response-compensated level control. A minimum level of  $-20$  dBm can be set. This range can be extended to  $-110$  dB with the optional RF Attenuator R&S®SMR-B18.

### Stable output frequency

The crystal reference built in as standard ensures an accurate, low-drift output frequency. The R&S®SMR50/60 can be fitted with the optional OCXO Reference Oscillator R&S®SMR-B1 to satisfy the most stringent requirements in terms of accuracy and aging.

### High output level saves you real cash

All microwave test setups involve high losses caused by the use of long cables, power dividers, directional couplers and RF relays. Expensive microwave amplifiers are usually the only means to remedy this. But not with the R&S®SMR50/60: the high output power provided by these generators eliminates the need for such a costly component.

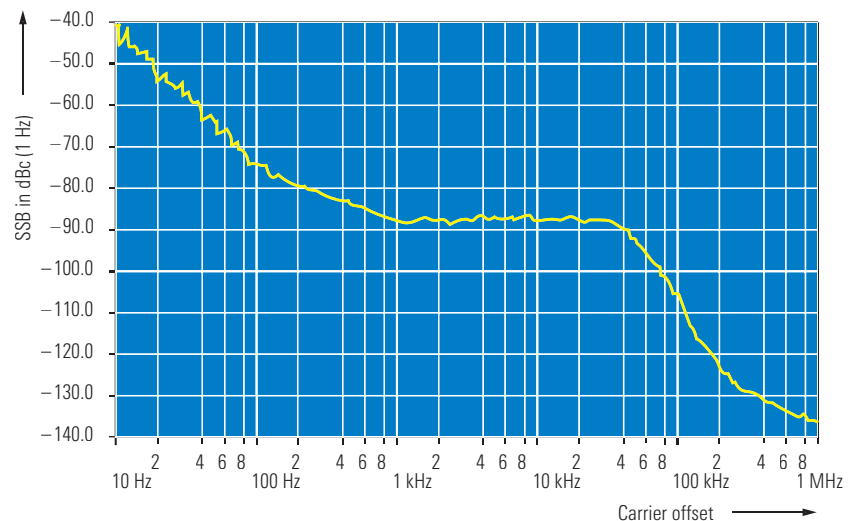

FIG 1: SSB phase noise at 10 GHz

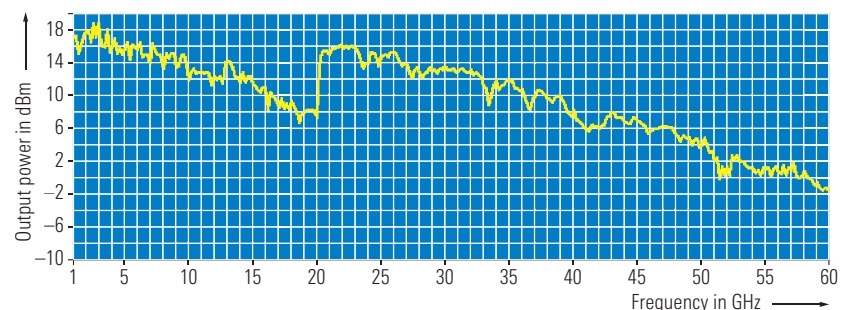

FIG 2: Typical max. output level as a function of frequency with RF Attenuator R&S®SMR-B18

# Options and applications

## Application-oriented frequency resolution

The standard frequency resolution of 1 kHz of the R&S®SMR50/60 offers a comfortable margin for most applications, for example frequency response measurements in the laboratory and in production and servicing. To satisfy more stringent requirements, e.g. for scientific applications and research, the R&S®SMR-B3 option is available to improve frequency resolution to 0.1 Hz.

## Pulse modulator included

Pulse modulation is still the most important modulation mode for microwave applications. Each of our basic units is, therefore, equipped with a high-quality pulse modulator. The on/off ratio is better than 80 dB, the rise/fall time shorter than 12 ns. Pulse widths of up to 25 ns are possible.

FIG 3 illustrates that the R&S®SMR50/60 are the ideal generators for use in the development, production and maintenance of radar equipment.

## Pulse generator option

The optional Pulse Generator R&S®SMR-B14 is an ideal complement to the pulse modulator for generating single and double pulses with pulse frequencies up to 10 MHz. The pulse generator can be

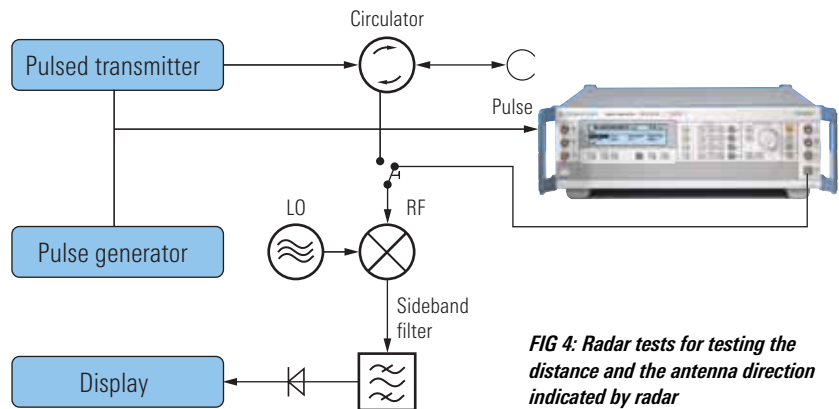

**FIG 4: Radar tests for testing the distance and the antenna direction indicated by radar**

triggered externally and operated in the external gate mode. The pulse width and delay are user-selectable over a wide range.

## Pulse radar with rotating antenna

Combined SCAN and pulse modulation provides the type of signals occurring in pulse radar applications with rotating antenna.

In the example shown in FIG. 4, the external pulse from the pulse generator or radar display is applied to the external pulse input of the R&S®SMR50/60 and used as a trigger for the internal pulse generator and modulator.

The main advantage of this kind of trigger is that it can be delayed to simulate the values on the display.

## Doppler effects

The combination of pulse and frequency modulation (FMDC) simulates Doppler effects and also chirp signals.

## Digital frequency and level sweeps

The digital frequency sweep with step times from 10 ms allows convenient frequency response measurements on microwave circuits. The start and stop frequencies are user-selectable. A trigger input enables synchronous operation with external equipment.

The very fast level sweep (with step times of min. 1 ms) up to 20 dB allows, for example, amplifier or mixer compression to be determined.

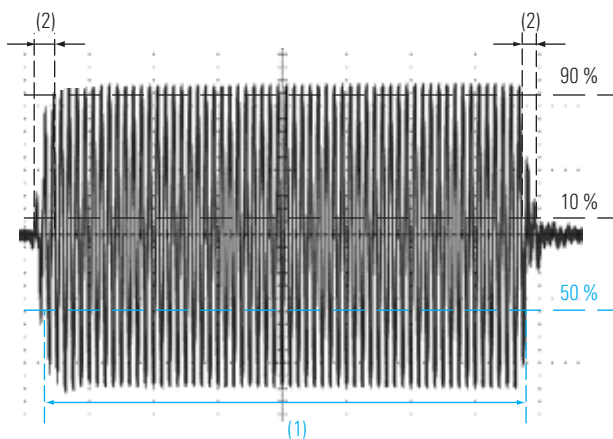

**FIG 3: Pulse modulator, universally used in microwave applications such as radar measurements**

## The world of applications

The R&S®SMR50/60 are ideal for use as a:

- ◆ Source for optical components
- ◆ Source for radar receiver tests
- ◆ Source for scalar network analysis
- ◆ Normal CW source for LO substitution

## Signal generator

### AM/FM/SCAN modulator option

The optional AM/FM/SCAN Modulator R&S®SMR-B5 turns the models into fully-fledged signal generators with AM and FM modulation capability. The option also includes an LF generator for sine-wave and squarewave signals from 0.1 Hz to 10 MHz.

### FM and FSK

The FM modulator has a modulation bandwidth from DC to 5 MHz. Digital frequency shift keying (FSK) is possible with data rates from 0 Hz to 2 MHz.

### Simultaneous modulation modes

All modulation modes of the R&S®SMR50/60 can be combined. This allows the generation of complex modulation signals for modern communication and location systems. The combination of pulse modulation and FM simulates Doppler effects or chirp signals. Simultaneous AM and pulse modulation provides the types of signal occurring in pulse radar applications with rotating antenna. The combination of FM and AM can be used to check fading effects of FM receivers.

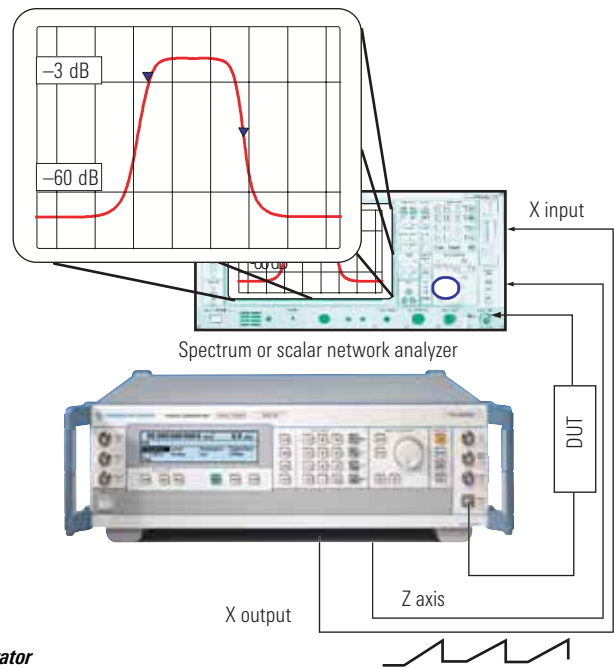

**FIG 5: Network analysis with R&S®SMR50/60 as synthesized sweep generator**

## Synthesized sweep generator

### Analog ramp sweep option

The analog ramp sweep mode corresponds to the analog sweep of classic sweep generators except that the sweep is fully synchronized over the complete range. In this way, the excellent frequency accuracy of digital step sweeps is achieved, and this at much higher sweep rates of min. 600 MHz/ms ( $f > 2$  GHz).

In conjunction with scalar network analyzers or suitable spectrum analyzers, realtime adjustment of microwave filters can be performed, for example (FIG 5).

To mark important frequency ranges such as filter bandwidths or the position of attenuation poles, the R&S®SMR50/60 have 10 user-selectable frequency markers which can be output as pulse markers at the marker output (TTL level) or alternatively modulated on the RF level as level markers (level reduction of 1 dB).



## User-defined correction of external frequency responses

The user correction function is extremely useful for fast RF sweeps, for example to compensate for nonlinearities of an amplifier.

The known frequency response can be compensated for by entering level correction values for up to 160 frequency points. The correction values for the frequencies between these points are determined by means of automatic interpolation (FIG 6).

In addition, the R&S®SMR50/60 can automatically measure the level correction values at a keystroke with the aid of external power meters such as the R&S®NRVS or R&S®NRVD.

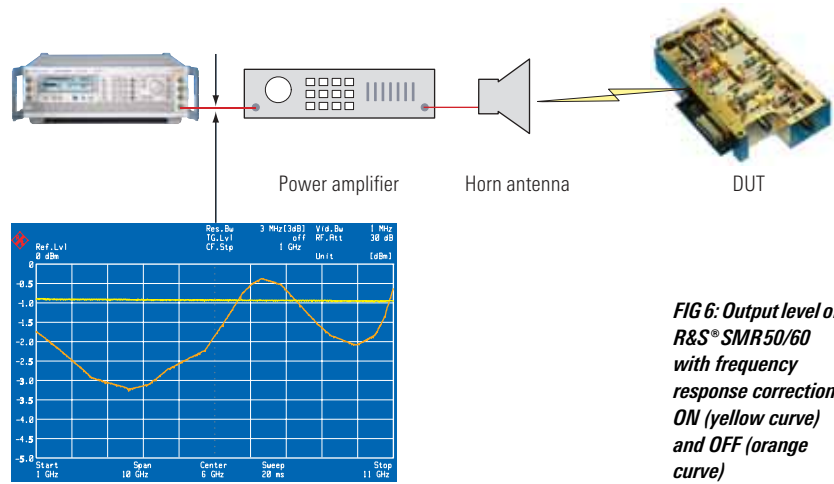

**FIG 6: Output level of R&S®SMR50/60 with frequency response correction ON (yellow curve) and OFF (orange curve)**

## External level control using a power meter

A very simple method is the external level control allowing very high level accuracy (FIG 7).

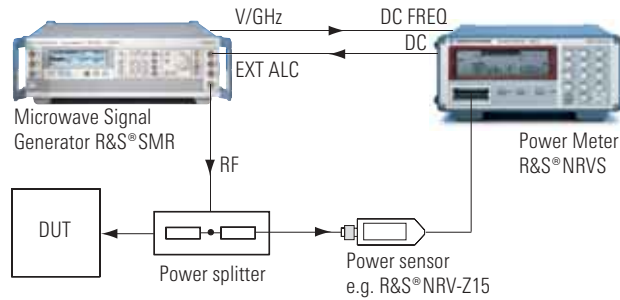
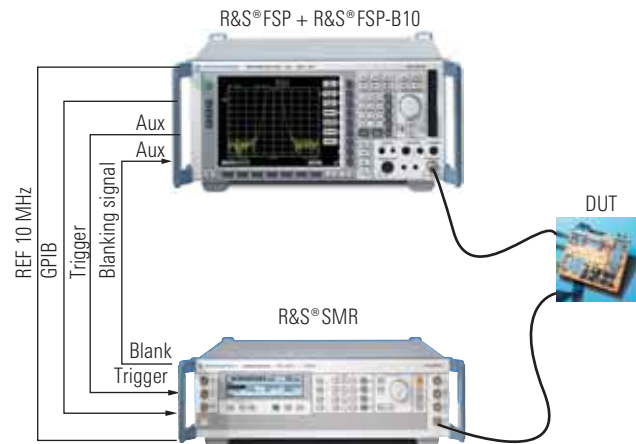

**FIG 7: External level control for Microwave Signal Generators R&S®SMR50/60**

## Scalar network analysis

The Microwave Signal Generators R&S®SMR50/60 used as tracking generators in conjunction with the Spectrum Analyzer R&S®FSP and the option R&S®FSP-B10 provide a unique scalar network analysis function. This application features an extremely wide dynamic range, which allows, for example, filter resonances in the stop band to be displayed at very low levels.

Due to the user-definable frequency offset, measurements on frequency-converting DUTs can also be performed with this configuration.



**FIG 8: Scalar network analysis with Microwave Signal Generators R&S®SMR50/60 and Spectrum Analyzer R&S®FSP with option R&S®FSP-B10**

50.000 000 000 0 GHz		0.0 dBm	
Modulation/FM			
FM Deviation	80.000 000 0 MHz		
FM Source	Off		
Ext1 Coupling	AC		
Ext2 Coupling	AC		
Ext1 Impedance	100 K $\Omega$		
Ext2 Impedance	100 K $\Omega$		
LFGen Freq	10.000 000 0 MHz		
LFGen Shape	Sin		
Back ↵			

The FM modulation menu shows the clear-cut representation of selectable parameters and current instrument status. Each setting can be made quickly and easily by means of the spinwheel and a few keys.

### Automatic measurement functions for production and test labs

The Save/Recall (red-framed) function provides convenient execution of standard test routines or frequently required sequences of different types of single measurements.

Up to 50 complete instrument setups can be stored.

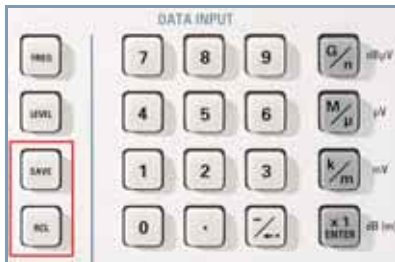

FIG 9: SAVE and RCL for storing and recalling settings

### Remote control to SCPI standard

The IEC/IEEE-bus remote control commands are in line with the SCPI guidelines. One of the advantages is that the user can exchange measuring instruments in an automatic system without having to modify the control software.

### Intelligent operating concept

#### Easy-to-follow menus

Neither multifunction keys nor obscure special functions burden the user. All functions are clearly arranged in menus. Menus and functions as well as parameter settings can conveniently and quickly be selected with a spinwheel.

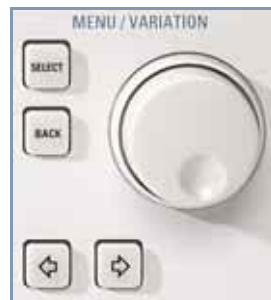

FIG 10: General settings and menu selection with spinwheel, Back, Select and arrow keys

### Menu memories

Frequently used menu settings can be stored in two memories and called at a keystroke.



FIG 11: Storage of menu settings

### HELP Function

Explanatory remarks can be called up for each individual menu. This does away with wasting time in looking up functions in a manual.



FIG 12: Online help



# EasyWheel – the trick with the click

## Transparent menu structure

The EasyWheel makes it extremely simple to operate the R&S®SMR50/60 user interface.

Just turn the wheel to go to the next menu item, and then press the wheel to perform the desired function.

There is no easier way to operate a measuring instrument!

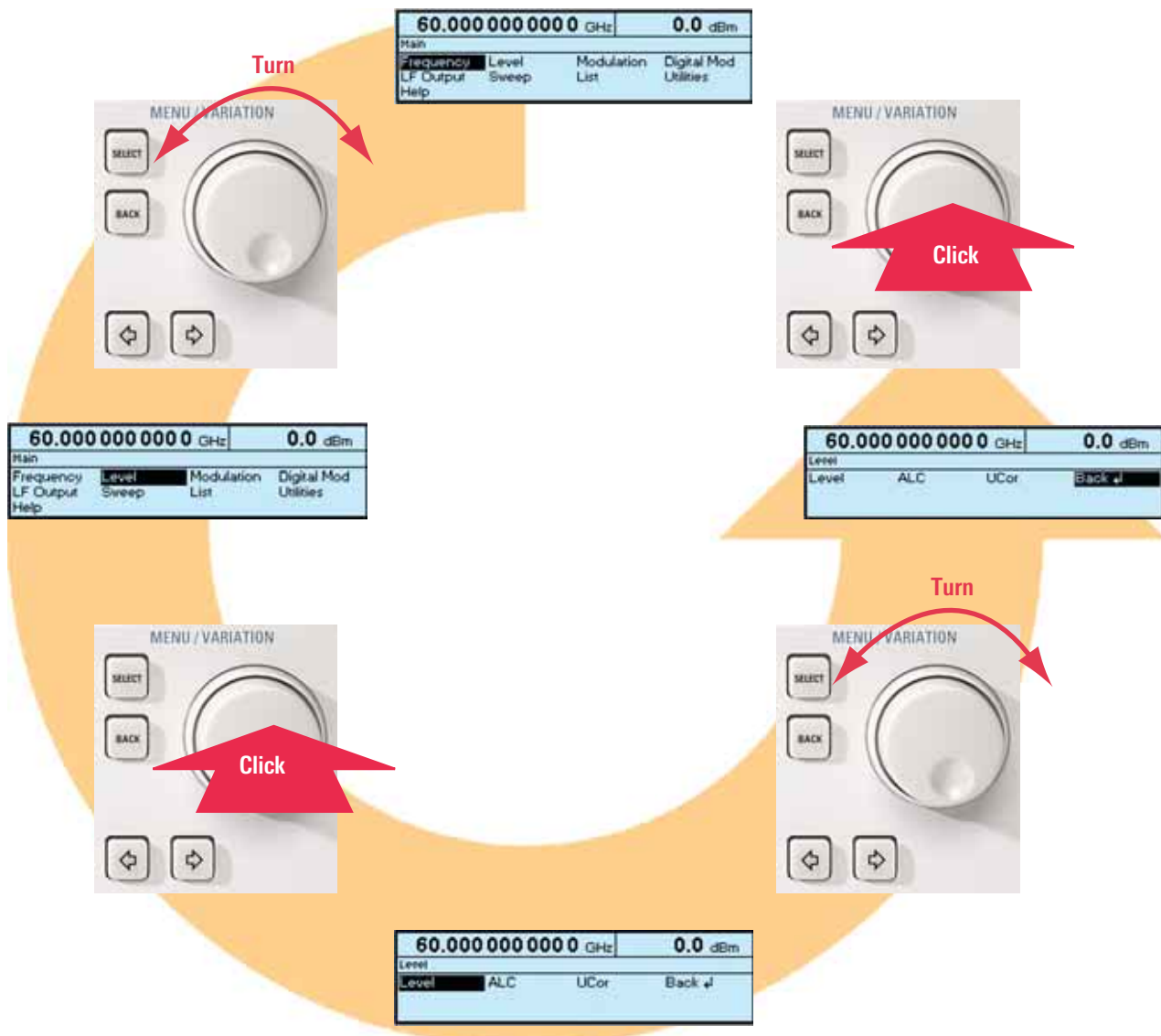

## Specifications

The specifications are valid under the following conditions:  
 30 minutes warm-up time, specified environmental conditions met, calibration cycle adhered to and total calibration performed.  
 Data designated "typ.", "overrange" or "under range" are not warranted.

Frequency	
R&S®SMR50 Without option R&S®SMR-B11 With option R&S®SMR-B11	1 GHz to 50 GHz 10 MHz to 50 GHz
R&S®SMR60 Without option R&S®SMR-B11 With option R&S®SMR-B11	1 GHz to 60 GHz 10 MHz to 60 GHz
Resolution Without option R&S®SMR-B3 With option R&S®SMR-B3	1 kHz 0.1 Hz
Setting time (to within $<1 \times 10^{-6}$ ) after IEC/IEEE-bus delimiter	$<10 \text{ ms} + 2 \text{ ms/GHz}$
<b>Reference frequency</b>	<b>Standard/Option R&amp;S®SMR-B1</b>
Aging (after 30 days of operation)	$1 \times 10^{-6}/\text{year} / <1 \times 10^{-7}/\text{year}$
Temperature effect (0°C to +55°C)	$2 \times 10^{-6} / <1 \times 10^{-10}/\text{°C}$
Warm-up time	–/ 15 min
Output for internal reference Frequency Level, $V_{\text{rms}}$ (EMF, sinewave) Source impedance	10 MHz 1 V 50 Ω
Input for external reference Frequency Permissible frequency drift Input level, $V_{\text{rms}}$ Input impedance	10 MHz $3 \times 10^{-6}$ 0.1 V to 2 V 50 Ω
Spectral purity	
Spurious signals Harmonics <sup>1)</sup> 30 MHz $< f \leq 20 \text{ GHz}^2)$ $f > 20 \text{ GHz}^3)$ Subharmonics $f \leq 20 \text{ GHz}$ $f > 20 \text{ GHz}$ Nonharmonics (>50 kHz from carrier) $f \leq 20 \text{ GHz}$ $20 \text{ GHz} < f \leq 40 \text{ GHz}$ $f > 40 \text{ GHz}$	$<-55 \text{ dBc}$ $<-40 \text{ dBc}$ $<-65 \text{ dBc}$ $<-30 \text{ dBc}$ $<-60 \text{ dBc}$ $<-54 \text{ dBc}$ $<-52 \text{ dBc}$
SSB phase noise ( $f = 10 \text{ GHz}$ , 10 kHz from carrier, 1 Hz bandwidth, CW, FM off)	$<-83 \text{ dBc}$
Residual FM, rms ( $f = 10 \text{ GHz}$ , FM off) 0.3 kHz to 3 kHz 0.02 kHz to 23 kHz	$<20 \text{ Hz}$ $<200 \text{ Hz}$
Level	
Maximum level <sup>4)</sup> Frequency range 0.01 GHz $\leq f < 1 \text{ GHz}$ 1 GHz $\leq f < 18 \text{ GHz}$ 18 GHz $\leq f \leq 20 \text{ GHz}$ 20 GHz $< f \leq 27 \text{ GHz}$ 27 GHz $< f \leq 30 \text{ GHz}$ 30 GHz $< f \leq 40 \text{ GHz}$ 40 GHz $< f \leq 50 \text{ GHz}$ 50 GHz $< f \leq 60 \text{ GHz}$	without option R&S®SMR-B18/ with option R&S®SMR-B18 $>+11 \text{ dBm}$ $>+8 \text{ dBm} / >+7 \text{ dBm}$ $>+7 \text{ dBm} / >+5 \text{ dBm}$ $>+11 \text{ dBm} / >+9 \text{ dBm}$ $>+9 \text{ dBm} / >+7 \text{ dBm}$ $>+7 \text{ dBm} / >+5 \text{ dBm}$ $>+3 \text{ dBm} / >+0 \text{ dBm}$ $>0 \text{ dBm} / >-4 \text{ dBm}$
Minimum level of all models Without option R&S®SMR-B18 With option R&S®SMR-B18	$-20 \text{ dBm}$ $-110 \text{ dBm}$
Resolution	0.1 dB or 0.01 dB, selectable

Total deviation (level = $-4 \text{ dBm}$ ) $f \leq 20 \text{ GHz}$ $20 \text{ GHz} < f \leq 40 \text{ GHz}$ $f > 40 \text{ GHz}$	$<1 \text{ dB}$ $<1.4 \text{ dB}$ $<1.8 \text{ dB}$
Frequency response (level = $-4 \text{ dBm}$ ) $f \leq 20 \text{ GHz}^5)$ $20 \text{ GHz} < f \leq 40 \text{ GHz}$ $f > 40 \text{ GHz}$	$<0.5 \text{ dB}$ , typ. $<\pm 0.3 \text{ dB}$ $<0.7 \text{ dB}$ , typ. $<\pm 0.4 \text{ dB}$ $<0.9 \text{ dB}$ , typ. $<\pm 0.5 \text{ dB}$
Impedance	50 Ω
SWR	$<2$
Setting time after IEC/IEEE-bus delimiter With option R&S®SMR-B18, with switching in attenuator	$<10 \text{ ms}$ $<25 \text{ ms}$
Range for non-interrupting level setting	$>16 \text{ dB}$
Linear amplitude modulation with option R&S®SMR-B5	
Operating modes	internal, external AC/DC
Modulation depth <sup>6)</sup>	0% to 100%
Resolution	0.1%
Setting accuracy (AF = 1 kHz, $m < 80\%$ ) <sup>7)</sup>	$<4\%$ of reading +1%
AM distortion (AF = 1 kHz, $m = 60\%$ ) <sup>7)</sup> $f < 1 \text{ GHz}$ $f \geq 1 \text{ GHz}$	$<3\%$ $<1\%$
Modulation frequency response ( $m = 60\%$ ) <sup>7)</sup> $f < 1 \text{ GHz}$ DC to 50 kHz $f \geq 1 \text{ GHz}$ 20 Hz to 20 kHz DC to 100 kHz	$<3 \text{ dB}$ $<1 \text{ dB}$ $<3 \text{ dB}$
Incidental φM with AM, peak value (AF = 1 kHz, $m = 30\%$ )	$<0.4 \text{ rad}$
EXT1, EXT2 modulation input Input impedance Input voltage $V_p$ for selected modulation depth	50 Ω/600 Ω <sup>8)</sup> or 100 kΩ 1 V (high/low indication for inaccuracy $>3\%$ )
Logarithmic amplitude modulation with option R&S®SMR-B5 (SCAN AM)	
Operating modes	internal, external
Dynamic range	$>20 \text{ dB}$
Sensitivity	$\pm 0.1 \text{ dB/V}$ to $\pm 10 \text{ dB/V}$
Resolution	0.01 dB
Rise/fall time (10%/90%)	$<10 \mu\text{s}$
EXT1, EXT2 modulation input Input impedance Input voltage range	50 Ω/600 Ω <sup>8)</sup> or 100 kΩ $-6 \text{ V}$ to $+6 \text{ V}$
Frequency modulation with option R&S®SMR-B5	
Operating modes	internal, external AC/DC
Maximum deviation $f \leq 15.625 \text{ MHz}$ 15.625 MHz $< f \leq 31.25 \text{ MHz}$ 31.25 MHz $< f \leq 62.5 \text{ MHz}$ 62.5 MHz $< f \leq 125 \text{ MHz}$ 125 MHz $< f \leq 250 \text{ MHz}$ 250 MHz $< f \leq 500 \text{ MHz}$ 500 MHz $< f < 1 \text{ GHz}$ 1 GHz $\leq f \leq 2 \text{ GHz}$ 2 GHz $< f \leq 10 \text{ GHz}$ 10 GHz $< f \leq 20 \text{ GHz}$ 20 GHz $< f \leq 40 \text{ GHz}$ $f > 40 \text{ GHz}$	39.0625 kHz 78.125 kHz 156.25 kHz 312.5 kHz 625 kHz 1.25 MHz 2.5 MHz 5 MHz 10 MHz 20 MHz 40 MHz 80 MHz
Resolution	$<1\%$ , min. 10 Hz

Setting accuracy (AF = 1 kHz)	<5% of reading + 20 Hz
FM distortion (AF = 1 kHz, half max. deviation)	<0.5%
Modulation frequency range	DC to 5 MHz
Modulation frequency response	<3 dB
Carrier frequency offset with FM f ≤ 15.625 MHz 15.625 MHz < f ≤ 31.25 MHz 31.25 MHz < f ≤ 62.5 MHz 62.5 MHz < f ≤ 125 MHz 125 MHz < f ≤ 250 MHz 250 MHz < f ≤ 500 MHz 500 MHz < f < 1 GHz 1 GHz ≤ f ≤ 2 GHz 2 GHz < f ≤ 10 GHz 10 GHz < f ≤ 20 GHz 20 GHz < f ≤ 40 GHz f > 40 GHz	0.39 Hz + 1% of deviation 0.78 Hz + 1% of deviation 1.56 Hz + 1% of deviation 3.13 Hz + 1% of deviation 6.25 Hz + 1% of deviation 12.5 Hz + 1% of deviation 25 Hz + 1% of deviation 50 Hz + 1% of deviation 100 Hz + 1% of deviation 200 Hz + 1% of deviation 400 Hz + 1% of deviation 800 Hz + 1% of deviation
EXT1, EXT2 modulation input Input impedance Input voltage V <sub>p</sub> for selected deviation	50 Ω/600 Ω <sup>9)</sup> or 100 kΩ 1 V (high/low indication for inaccuracy >3%)
<b>ASK modulation with option R&amp;S®SMR-B5</b>	
Operating modes	external
Maximum modulation depth	90%
Resolution	0.1%
Data rate f < 1 GHz f ≥ 1 GHz	0 Hz to 100 kHz 0 Hz to 200 kHz
Rise/fall time (10%/90%) f < 1 GHz f ≥ 1 GHz	<10 μs <5 μs
EXT1 modulation input Input impedance Input level	50 Ω/600 Ω <sup>9)</sup> or 100 kΩ TTL/HCT signal, selectable polarity
<b>FSK modulation with option R&amp;S®SMR-B5</b>	
Operating modes	external
Maximum deviation f ≤ 15.625 MHz 15.625 MHz < f ≤ 31.25 MHz 31.25 MHz < f ≤ 62.5 MHz 62.5 MHz < f ≤ 125 MHz 125 MHz < f ≤ 250 MHz 250 MHz < f ≤ 500 MHz 500 MHz < f < 1 GHz 1 GHz ≤ f ≤ 2 GHz 2 GHz < f ≤ 10 GHz 10 GHz < f ≤ 20 GHz 20 GHz < f ≤ 40 GHz f > 40 GHz	39.0625 kHz 78.125 kHz 156.25 kHz 312.5 kHz 625 kHz 1.25 MHz 2.5 MHz 5 MHz 10 MHz 20 MHz 40 MHz 80 MHz
Resolution	<1%, min. 10 Hz
Data rate	0 Hz to 2 MHz
Rise/fall time (10%/90%)	<500 ns
EXT1 modulation input Input impedance Input level	50 Ω/600 Ω <sup>9)</sup> or 100 kΩ TTL/HCT signal, selectable polarity
<b>Pulse modulation</b>	
Operating modes	external, internal only with option R&S®SMR-B14
On/off ratio	>80 dB

Rise/fall time (10%/90%) 62.5 MHz ≤ f ≤ 125 MHz 125 MHz < f ≤ 450 MHz f > 450 MHz	<50 ns <sup>9)</sup> <20 ns <sup>9)</sup> <12 ns <sup>9)</sup>
Minimum pulse width With level control on (ALC ON) With level control off (ALC OFF)	500 ns 25 ns
Maximum pulse pause With level control on (ALC ON) With level control off (ALC OFF)	40 ms any
Minimum pulse/pause ratio With level control on (ALC ON) With level control off (ALC OFF)	1/100 any
Maximum pulse repetition frequency 62.5 MHz ≤ f ≤ 125 MHz 125 MHz < f ≤ 450 MHz f > 450 MHz	1 MHz 2 MHz 10 MHz
Pulse delay	typ. 50 ns
Video feedthrough V <sub>pp</sub>	<20 mV
PULSE modulation input Input level  Input impedance	TTL/HCT signal or selectable switching thresholds at +0.5 V or -2.5 V 50 Ω (max. 2 W, overload protection) or 10 kΩ
<b>Simultaneous modulation</b>	
FM (FSK) is independent of AM (SCAN AM, ASK) and pulse modulation. Reduced AM bandwidth for simultaneous AM (SCAN AM, ASK) and pulse modulation.	
<b>LF generator with option R&amp;S®SMR-B5</b>	
Frequency range	0.1 Hz to 10 MHz
Resolution	0.1 Hz
Waveforms	sinewave, squarewave
Frequency drift	<1 × 10 <sup>-4</sup>
Frequency response (up to 500 kHz)	<0.5 dB
Distortion (up to 100 kHz)	<0.5% (R <sub>L</sub> > 200 Ω, level = 0.5 V)
Open-circuit voltage V <sub>p</sub> (LF connector)	40 mV to 3.5 V
Resolution	1 mV
Setting accuracy (at 1 kHz)	1.5%
Output impedance	approx. 10 Ω
Frequency setting time (after IEC/IEEE-bus delimiter)	<10 ms
<b>R&amp;S®SMR-B14 pulse generator option</b>	
Operating modes	single or double pulse (automatically or externally triggered), delayed pulse (externally triggered), gate mode (external)
Active trigger edge	positive or negative
Pulse repetition period Resolution Accuracy	100 ns to 85 s 5 digit, min. 20 ns <1 × 10 <sup>-4</sup>
Pulse width Resolution Accuracy	20 ns to 1 s 4 digit, min. 20 ns <(1 × 10 <sup>-4</sup> + 3 ns)
Pulse delay Resolution Accuracy	20 ns to 1 s 4 digit, min. 20 ns <(1 × 10 <sup>-4</sup> + 3 ns)
Double pulse Resolution Accuracy	60 ns to 1 s 4 digit, min. 20 ns <(1 × 10 <sup>-4</sup> + 3 ns)

Trigger delay	typ. 50 ns
Jitter	<10 ns
PULSE modulation input Input level	TTL/HCT signal or selectable switching thresholds at +0.5 V or -2.5 V
Input impedance	50 Ω (max. 2 W, overload protection) or 10 kΩ
SYNC output	TTL/ACT signal ( $R_L \geq 50 \Omega$ ), 40 ns pulse width
PULSE/VIDEO output	TTL/ACT signal ( $R_L \geq 50 \Omega$ )
<b>Digital sweep, sweep in discrete steps</b>	
RF sweep, AF sweep Operating modes	automatic, single-shot, manual or externally triggered, linear or logarithmic
Sweep range	user-selectable
Step width (lin)	user-selectable
Step width (log)	0.01% to 100%
Step time	10 ms to 5 s
Resolution	0.1 ms
Level sweep Operating modes	automatic, single-shot, manual or externally triggered, logarithmic
Sweep range	0 dB to $\geq 16$ dB
Step width	0.01 dB to 20 dB
Step time	1 ms to 5 s
Resolution	0.1 ms
Markers	10, user-selectable
MARKER output signal	TTL level, selectable polarity
X output	0 V to 10 V
BLANK output signal	TTL level, selectable polarity
<b>R&amp;S®SMR-B4 ramp sweep option</b>	
RF sweep	automatic, single-shot, manual or externally triggered
Operating modes	Start/Stop, center frequency/span
Sweep range	user-selectable, ascending
Resolution	1 kHz
Accuracy	(0.005% of deviation)/(sweep time/s) + reference error
Sweep time <sup>10)</sup>	10 ms to 100 s

Maximum sweep rate	2.34375 MHz/ms
$f \leq 15.625$ MHz	4.6875 MHz/ms
$15.625$ MHz < $f \leq 31.25$ MHz	9.375 MHz/ms
$31.25$ MHz < $f \leq 62.5$ MHz	18.75 MHz/ms
$62.5$ MHz < $f \leq 125$ MHz	37.5 MHz/ms
$125$ MHz < $f \leq 250$ MHz	75 MHz/ms
$250$ MHz < $f \leq 500$ MHz	150 MHz/ms
$500$ MHz < $f < 1$ GHz	300 MHz/ms
$1$ GHz $\leq f \leq 2$ GHz	600 MHz/ms
$2$ GHz < $f \leq 10$ GHz	1200 MHz/ms
$10$ GHz < $f \leq 20$ GHz	2400 MHz/ms
$20$ GHz < $f \leq 40$ GHz	4800 MHz/ms
$f > 40$ GHz	
Markers	10, user-selectable
MARKER output signal	TTL level, selectable polarity
X output	0 V to 10 V
BLANK output signal	TTL level, selectable polarity
<b>List mode</b>	
Frequency and level values can be stored in a list.	
Permissible level variation	max. 20 dB
Operating modes	auto, single-shot, manual or externally triggered
Maximum number of frequency/level entries	2003
Maximum number of lists	10
Step time	1 ms to 5 s
Resolution	0.1 ms
<b>Memory for instrument setups</b>	
Storable setups	50
<b>Remote control</b>	
System	IEC 60625-1 (IEEE 488.1) Rev 2003
Command set	SCPI 1995.0
Connector	24-contact Amphenol
IEC/IEEE-bus address	0 to 30, selectable
Interface functions	SH1, AH1, T6, L4, SR1, RL1, PP1, DC1, DT1, C0

<sup>1)</sup> R&S®SMR50: level <0 dBm.

R&S®SMR60: level <0 dBm at  $f \leq 50$  GHz or <-4 dBm at  $f > 50$  GHz.

<sup>2)</sup> 10 MHz  $\leq f \leq 30$  MHz: typ. <-50 dBc.

<sup>3)</sup> Specifications for harmonics above 50 GHz (R&S®SMR50) and 60 GHz (R&S®SMR60) only typical.

<sup>4)</sup> The maximum level is reduced by up to 2 dB in the temperature range 35°C to 55°C.

<sup>5)</sup> From 10 MHz to 50 MHz, the specified total uncertainty is only valid in the temperature range 15°C to 35°C. The uncertainty outside this temperature range is likely to be higher by max. 0.7 dB.

<sup>6)</sup> The modulation depth adjustable with adherence to the AM specifications continuously decreases from 6 dB below the maximum level up to the maximum level.

<sup>7)</sup> This specification does not apply

a) to non-interrupting level setting (ATTENUATOR MODE FIXED) if option R&S®SMR-B18 is used,  
b) to levels below -8 dBm without option R&S®SMR-B18,  
c) to external level control mode (EXT ALC).

<sup>8)</sup> 50 Ω or 600 Ω selectable by means of internal jumpers.

<sup>9)</sup> Only valid if level control set to OFF (ALC OFF).

<sup>10)</sup>  $\leq 30$  ms switching time at 1 GHz, 2 GHz, 10 GHz, 20 GHz and 40 GHz.

## General data

Temperature resistance	
Operating temperature range	0°C to +55°C meets DIN EN 60068-2-1 Rev 1998 and DIN EN 60068-2-2 Rev 1998
Storage temperature range	-40°C to +70°C
Damp heat	95% relative humidity, cyclic test at +25°C/+40°C; meets DIN EN 60068-2-30 Rev 1998
Mechanical resistance	
Vibration, sinusoidal	5 Hz to 150 Hz, max. 2 g at 55 Hz, 0.5 g const. in range 55 Hz to 150 Hz, meets DIN EN 60068-2-6 Rev 1998, DIN EN 61001-1 Rev 1998 and MIL-T-28800D, class 5
Vibration, random	10 Hz to 300 Hz, acceleration 1.2 g (rms)
Shock	40 g shock spectrum, meets MIL-STD-810E, MIL-T-28800D, class 3/5
Electromagnetic compatibility	
	meets EN 55011 Rev 1998 + A1 Rev 1999 and EN 61326-1 Rev 1997 + A1 Rev 1998 (EMC directive of EU)
Radiated susceptibility	10 V/m
Power supply	
	100 V to 120 V (AC), 50 Hz to 400 Hz, 200 V to 240 V (AC), 50 Hz to 60 Hz, autoranging, max. 300 VA
Safety	
	meets DIN EN 61010-1 Rev 1994, IEC 61010-1 Rev 1995, UL 3111-1, CAN/CSA-C 22.2 No. 1010.1-B97
Dimensions (W × H × D)	426.7 mm × 131.4 mm × 450 mm
Weight	<13.5 kg when fully equipped

## Ordering information

Designation	Type	Order No.
Microwave Signal Generator	R&S®SMR50	1134.9008.50
Microwave Signal Generator	R&S®SMR60	1134.9008.60
RF output, V connector 1.85 mm, female		
Accessories supplied		
Power cable, operating manual		
Options		
OXC0 Reference Oscillator	R&S®SMR-B1	1104.5485.02
Frequency Resolution 0.1 Hz	R&S®SMR-B3	1104.5585.02
Ramp Sweep	R&S®SMR-B4	1104.5685.02
AM/FM/SCAN Modulator	R&S®SMR-B5	1104.3501.03
Frequency Extension 0.01 GHz to 1 GHz <sup>1)</sup>	R&S®SMR-B11	1104.4250.60
Pulse Generator	R&S®SMR-B14	1104.3982.02
RF Attenuator 60 GHz <sup>1)</sup>	R&S®SMR-B18	1135.2907.02
Rear Connectors for AF	R&S®SMR-B21	1135.2407.02
Recommended extras		
Service Kit	R&S®SMR-Z1	1103.9506.02
Interface Cable	R&S®SMR-Z3	1134.9772.02
19" Rack Adapter	R&S®ZZA-311	1096.3277.00

<sup>1)</sup> Factory-fitted option.

More information at  
[www.rohde-schwarz.com](http://www.rohde-schwarz.com)  
 (search term: SMR50/60)



# ROHDE & SCHWARZ

[www.rohde-schwarz.com](http://www.rohde-schwarz.com)

R&S® is a registered trademark of Rohde & Schwarz GmbH & Co. KG · Trade names are trademarks of the owners  
 PD 0758.1893.32 · R&S®SMR50/60 · Version 03.00 · July 2004 · Data without tolerance limits is not binding · Subject to change