



ABN 43 064 478 842

231 Osborne Avenue Clayton South, VIC 3169  
PO Box 1548, Clayton South, VIC 3169  
t 03 9265 7400 f 03 9558 0875  
freecall 1800 680 680  
www.tmgtestequipment.com.au

## Test & Measurement

- > sales
- > rentals
- > calibration
- > repair
- > disposal

## Complimentary Reference Material

This PDF has been made available as a complimentary service for you to assist in evaluating this model for your testing requirements.

TMG offers a wide range of test equipment solutions, from renting short to long term, buying refurbished and purchasing new. Financing options, such as Financial Rental, and Leasing are also available on application.

TMG will assist if you are unsure whether this model will suit your requirements.

Call TMG if you need to organise repair and/or calibrate your unit.

If you click on the "Click-to-Call" logo below, you can call us for FREE!

TMG Corporate Website

TMG Products Website



Click-to-Call  
TMG Now



Product Lifecycle Management System

### Disclaimer:

All trademarks appearing within this PDF are trademarks of their respective owners.



# Instructions



**P6139A**  
**10X Passive Probe**  
**063-0870-05**

[www.tektronix.com](http://www.tektronix.com)



063087005

Copyright © Tektronix, Inc. All rights reserved.

Tektronix products are covered by U.S. and foreign patents, issued and pending. Information in this publication supercedes that in all previously published material. Specifications and price change privileges reserved.

Tektronix, Inc., P.O. Box 500, Beaverton, OR 97077-1000

TEKTRONIX and TEK are registered trademarks of Tektronix, Inc.

## WARRANTY

Tektronix warrants that the products that it manufactures and sells will be free from defects in materials and workmanship for a period of one (1) year from the date of purchase from an authorized Tektronix distributor. If any such product proves defective during this warranty period, Tektronix, at its option, either will repair the defective product without charge for parts and labor, or will provide a replacement in exchange for the defective product. Batteries are excluded from this warranty.

In order to obtain service under this warranty, Customer must notify Tektronix of the defect before the expiration of the warranty period and make suitable arrangements for the performance of service. Customer shall be responsible for packaging and shipping the defective product to the service center designated by Tektronix, shipping charges prepaid, and with a copy of customer proof of purchase. Tektronix shall pay for the return of the product to Customer if the shipment is to a location within the country in which the Tektronix service center is located. Customer shall be responsible for paying all shipping charges, duties, taxes, and any other charges for products returned to any other locations.

This warranty shall not apply to any defect, failure or damage caused by improper use or improper or inadequate maintenance and care. Tektronix shall not be obligated to furnish service under this warranty a) to repair damage resulting from attempts by personnel other than Tektronix representatives to install, repair or service the product; b) to repair damage resulting from improper use or connection to incompatible equipment; c) to repair any damage or malfunction caused by the use of non-Tektronix supplies; or d) to service a product that has been modified or integrated with other products when the effect of such modification or integration increases the time or difficulty of servicing the product.

**THIS WARRANTY IS GIVEN BY TEKTRONIX WITH RESPECT TO THE LISTED PRODUCTS IN LIEU OF ANY OTHER WARRANTIES, EXPRESS OR IMPLIED. TEKTRONIX AND ITS VENDORS DISCLAIM ANY IMPLIED WARRANTIES OF MERCHANTABILITY OR FITNESS FOR A PARTICULAR PURPOSE. TEKTRONIX' RESPONSIBILITY TO REPAIR OR REPLACE DEFECTIVE PRODUCTS IS THE SOLE AND EXCLUSIVE REMEDY PROVIDED TO THE CUSTOMER FOR BREACH OF THIS WARRANTY. TEKTRONIX AND ITS VENDORS WILL NOT BE LIABLE FOR ANY INDIRECT, SPECIAL, INCIDENTAL, OR CONSEQUENTIAL DAMAGES IRRESPECTIVE OF WHETHER TEKTRONIX OR THE VENDOR HAS ADVANCE NOTICE OF THE POSSIBILITY OF SUCH DAMAGES.**

## Contacting Tektronix

<b>Phone</b>	1-800-833-9200*
<b>Address</b>	Tektronix, Inc. Department or name (if known) 14200 SW Karl Braun Drive P.O. Box 500 Beaverton, OR 97077 USA
<b>Web site</b>	<a href="http://www.tektronix.com">www.tektronix.com</a>
<b>Sales support</b>	1-800-833-9200, select option 1*
<b>Service support</b>	1-800-833-9200, select option 2*
<b>Technical support</b>	Email: <a href="mailto:techsupport@tektronix.com">techsupport@tektronix.com</a> 1-800-833-9200, select option 3* 6:00 a.m. - 5:00 p.m. Pacific time

---

\* **This phone number is toll free in North America. After office hours, please leave a voice mail message. Outside North America, contact a Tektronix sales office or distributor; see the Tektronix web site for a list of offices.**

# General Safety Summary

Review the following safety precautions to avoid injury and prevent damage to this product or any products connected to it. To avoid potential hazards, use this product only as specified.

*Only qualified personnel should perform service procedures.*

## **To Avoid Fire or Personal Injury**

**Connect and Disconnect Properly.** Do not connect or disconnect probes or test leads while they are connected to a voltage source.

**Observe All Terminal Ratings.** To avoid fire or shock hazard, observe all ratings and markings on the product. Consult the product manual for further ratings information before making connections to the product.

The common terminal is at ground potential. Do not connect the common terminal to elevated voltages.

Do not apply a potential to any terminal, including the common terminal, that exceeds the maximum rating of that terminal.

**Do Not Operate With Suspected Failures.** If you suspect there is damage to this product, have it inspected by qualified service personnel.

**Do Not Operate in Wet/Damp Conditions.**

**Do Not Operate in an Explosive Atmosphere.**

**Keep Product Surfaces Clean and Dry.**

**Symbols and Terms**

**Terms in this Manual.** These terms may appear in this manual:



---

**WARNING.** *Warning statements identify conditions or practices that could result in injury or loss of life.*

---



---

**CAUTION.** *Caution statements identify conditions or practices that could result in damage to this product or other property.*

---

**Terms on the Product.** These terms may appear on the product:

DANGER indicates an injury hazard immediately accessible as you read the marking.

WARNING indicates an injury hazard not immediately accessible as you read the marking.

CAUTION indicates a hazard to property including the product.

**Symbols on the Product.** The following symbols may appear on the product:



DANGER  
High Voltage



Protective Ground  
(Earth) Terminal



ATTENTION  
Refer to Manual



Double  
Insulated

**Certifications and  
Compliances**

Refer to the specifications section for a listing of certifications and compliances that apply to this product.

# Operating Basics

The P6139A is a compact high impedance passive probe designed for use with Tektronix TDS3000 and TDS500 Series digitizing oscilloscopes. The P6139A has a 1.3 meter cable and is fully compatible with the Tektronix family of compact size (3.5 mm) probe accessories. The *Replaceable Parts* list beginning on page 7 identifies the standard and optional accessories for the P6139A probe.



**WARNING.** To avoid electric shock when using the probe, do not touch the metallic portions of the probe head while connected to a voltage source.

## Probe Compensation

Due to variations in oscilloscope input characteristics, probe low-frequency compensation may need adjustment after moving the probe from one oscilloscope to another. If a 1 kHz calibrated square wave displayed at 1 ms/division shows significant differences between the leading and trailing edges, perform the following steps to optimize low-frequency compensation.

1. Connect the probe to the calibration signal on the oscilloscope front panel.
2. Press **AUTOSET** or otherwise adjust your digitizing oscilloscope to display a meaningful waveform.
3. Adjust the trimmer in the probe (accessible through the compensation box) until you see a perfectly flat-top square wave on the display. See Figure 1.

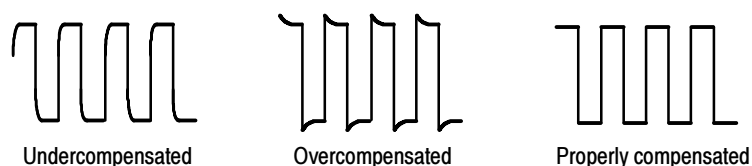

**Figure 1: Probe compensation waveforms**

## Cleaning

To remove accumulated dirt from the probe exterior, use a soft cloth dampened with a mild detergent and water solution or isopropyl alcohol. Do not use solvents such as benzene, toluene, xylene, or acetone. Avoid abrasive cleaners.



# Features and Accessories

Table 1 illustrates the features and standard accessories of the P6139A probe.

**Table 1: Features and Accessories**

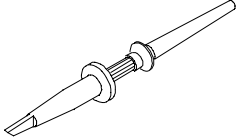
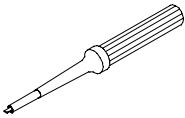
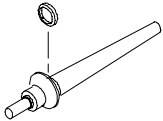
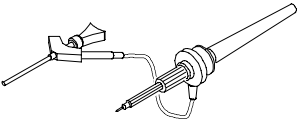
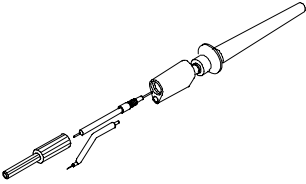
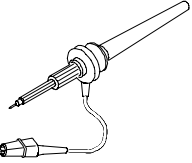
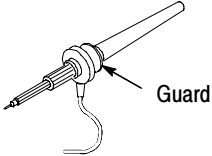
Feature/Accessory	Description	Applications/Notes
	Retractable hook tip	Connects the probe tip to wires and component leads for hands-free measurement. <b>NOTE.</b> For a solid connection, firmly push and twist the hook tip onto the probe tip before using.
	Adjustment tool	Used to adjust probe compensation. Access the adjustment through the opening in the compensation box.
	Color marker bands	Color codes the probe to the oscilloscope input when more than one probe is in use. Clip one band around the strain relief of the probe head and the matching band on the strain relief of probe output.
	SMT KlipChip™ and ground lead	Connects the probe ground to small or hard to reach ground reference points.
	Low-inductance ground	The ground collar and short lead connect the probe ground to a ground reference close to the signal source. The short lead minimizes aberrations on high-frequency signals caused by the inductance of the ground lead.
	Ground lead with insulated alligator clip	Connects the probe ground to ground reference.
	Guard	Keeps fingers away from the probe tip for protection against electric shock.



**WARNING.** To avoid electric shock when using the probe, keep fingers behind the guard on the probe body.

# Specifications

The characteristics listed in Table 2 apply to a P6139A probe installed on a Tektronix TDS3054 oscilloscope unless otherwise noted.

Specifications apply when the instrument warms up for a period of at least 20 minutes in an environment that does not exceed the limits described in Table 3 on page 4.

**Table 2: Electrical characteristics**

Characteristic	Description
Attenuation <sup>1</sup>	10X ±0.5% at DC
Input Resistance <sup>1</sup>	10 MΩ ±0.5%
Input Capacitance	8.0 pF (±0.8 pF)
Compensation Range	8 pF to 18 pF
System Bandwidth (-3 dB)	500 MHz (TDS3054) or TDS500 series 100 MHz (TDS3012)
Maximum Input Voltage <sup>2,3</sup>	400 V RMS CAT I or 400 V DC CAT I 300 V RMS CAT II or 300 V DC CAT II 150 V RMS CAT III or 150 V DC CAT III 590 V peak, <50% DF, <1 sec PW 930 V peak, <20% DF, <1 sec PW 1250 V peak, <10% DF, <50 μsec PW See Figure 4 for voltage derating curve.

<sup>1</sup> System characteristic.

<sup>2</sup> As defined in EN61010-1. See Certifications and compliances in Table 4.

<sup>3</sup> RMS=Root Mean Square=rms=The square root of the average of the sum of the squares of the instantaneous voltage in one cycle =  $\sqrt{\sum (fx_i)^2/n}$  .

300 VDC=300V RMS, 420 V Peak (sinewave)=300 V RMS See Figure 2.

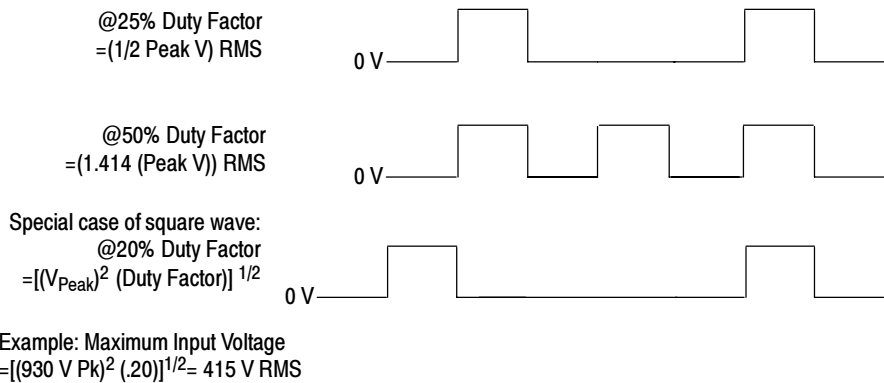
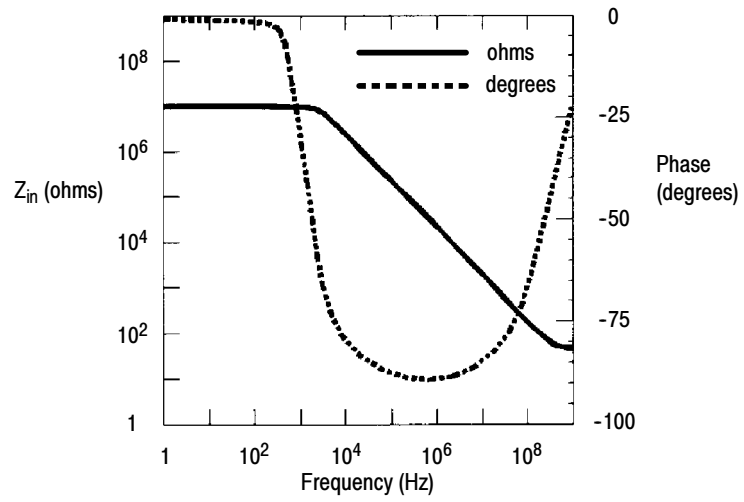

**Figure 2: Maximum input voltage calculation example**

**Table 3: Physical and environmental characteristics**

Characteristic	Description
Net Weight (Including Accessories)	<110 g (0.24 lb)
Temperature Range	
Operating	-15° C to +65° C (+5° F to +149° F)
Nonoperating	-62° C to +85° C (-80° F to +185° F)
Humidity <sup>1</sup>	Five cycles (120 hr) at 95% to 97% relative humidity
Altitude	< 2000 meters

<sup>1</sup> Tektronix standard 062-2847-00, class 3. Refer to MIL-E-16400F, paragraph 4.5.9 through 4.5.9.5.1, class 4.



**Figure 3: Typical P6139A input impedance**

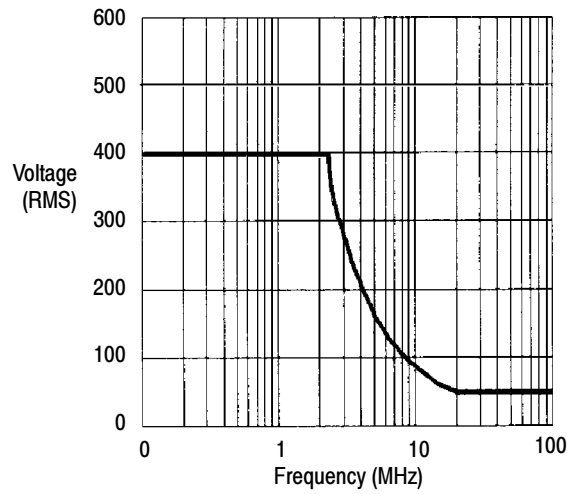

**Figure 4: Typical P6139A voltage derating**

**Table 4: Certifications and compliances**

<p>EC Declaration of Conformity</p>	<p>Compliance was demonstrated to the following specification as listed in the Official Journal of the European Communities:</p> <p>Low Voltage Directive 73/23/EEC as amended by 93/68/EEC:</p> <p>EN 61010-1/A2                      Safety requirements for electrical equipment for measurement, control, and laboratory use</p> <p>EN 61010-2-031:1994              Particular requirements for hand-held probe assemblies for electrical measurement and test</p>								
<p>Overvoltage Category</p>	<table border="0"> <tr> <td>Category:</td> <td>Examples of Products in this Category:</td> </tr> <tr> <td>CAT III</td> <td>Distribution-level mains, fixed installation</td> </tr> <tr> <td>CAT II</td> <td>Local-level mains, appliances, portable equipment</td> </tr> <tr> <td>CAT I</td> <td>Signal levels in special equipment or parts of equipment, telecommunications, electronics</td> </tr> </table>	Category:	Examples of Products in this Category:	CAT III	Distribution-level mains, fixed installation	CAT II	Local-level mains, appliances, portable equipment	CAT I	Signal levels in special equipment or parts of equipment, telecommunications, electronics
Category:	Examples of Products in this Category:								
CAT III	Distribution-level mains, fixed installation								
CAT II	Local-level mains, appliances, portable equipment								
CAT I	Signal levels in special equipment or parts of equipment, telecommunications, electronics								
<p>Pollution Degree 2</p>	<p>Do not operate in environments where conductive pollutants may be present.</p>								
<p>Safety</p>	<p>UL3111-1, First Edition &amp; IEC61010-2-031, First Edition          CSA C22.2 No. 1010.1-92 &amp; CAN/CSA C22.2 No. 1010.2.031-94          EN61010-1/A2          EN61010-2-031          Pollution Degree 2</p>								

# Replaceable Parts

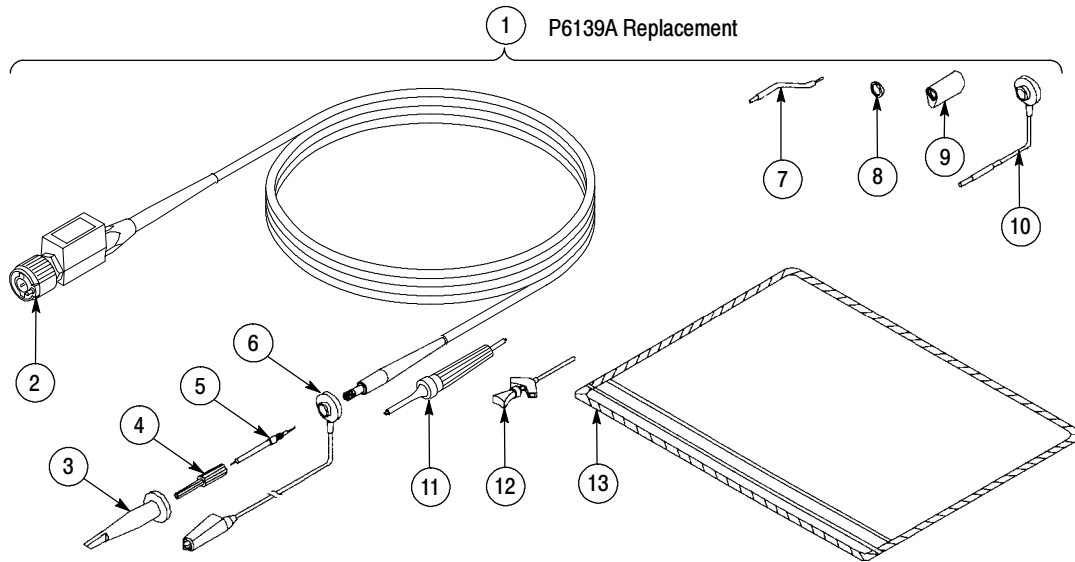

Figure 5: P6139A probe with standard accessories

**Replaceable parts: P6139A probe and standard accessories**

Fig. & index number	Tektronix part number	Serial no. effective	Serial no. discont'd	Qty	Name & description	Mfr. code	Mfr. part number
<b>P6139A</b>							
5 -1	P6139A			1	P6139A PASSIVE PROBE REPLACEMENT		
<b>STANDARD ACCESSORIES</b>							
-2	131-3219-00			1	CONN,RF PLUG:BNC,MALE	24931	28P266-3
-3	013-0107-07			1	TIP,PROBE:MINIATURE/COMPACT SIZE, RETRACTABLE HOOK ASSY	80009	013-0107-07
-4	204-1049-00			1	BODY SHELL:TIP COVER	TK2565	204-1049-00
-5	206-0441-00			1	PROBE TIP ASSY:10X,8.0PF,9M OHM	80009	206-0441-00
-6	196-3305-00			1	LEAD,ELECTRICAL:22 AWG,6.0 L,W/CLIP	TK2469	196-3305-00
-7	195-4240-00			1	LEAD,ELECTRICAL:0.025 DIA,COPPER,2.3 L	TK2469	195-4240-00
-8	016-0633-00			1	MARKER SET,CA:2 EA VARIOUS COLORS	80009	016-0633-00
-9	343-1003-01			1	COLLAR,GND:P6130	TK2565	343-1003-01
-10	196-3113-02			1	LEAD,ELECTRICAL:STRD,22 AWG,6.0 L,8-N	TK2469	196-3113-02
-11	003-1433-02			1	SCREWDRIVER:ADJUSTMENT TOOL	TK2565	003-1433-02
-12	206-0364-00			1	TIP,PROBE:MICROCKT TEST,0.05 CTR	80009	206-0364-00
-13	-----			1	POUCH,ACCESSORY:		
	063-0870-XX			1	DATA SHEET:TECHNICAL,P6139A,DP	TK2548	063-0870-XX

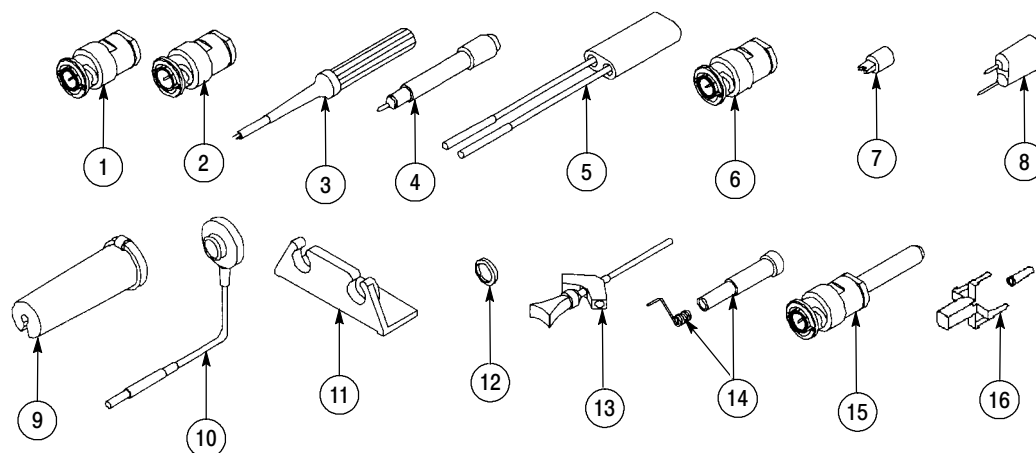

Figure 6: P6139A probe optional accessories

Replaceable parts: P6139A probe optional accessories

Fig. & index number	Tektronix part number	Serial no. effective	Serial no. discont'd	Qty	Name & description	Mfr. code	Mfr. part number
<b>OPTIONAL ACCESSORIES</b>							
6 -1	013-0226-00			1	CONNECTOR,BNC:BNC TO PROBE TIP ADAPTER	24931	28P264-2
-2	013-0227-00			1	CONNECTOR,BNC:50 OHM,BNC TO P TIP ADAPTER	24931	28P312-1
-3	003-1433-02			1	SCREWDRIVER:ADJUSTMENT TOOL	80009	003-1433-02
-4	013-0202-03			1	ADAPTER,PROBE:SUBMINIATURE/COMPACT TO MIN	TK2565	013-0202-03
					NOTE: ITEMS 5 THROUGH 9 ARE USABLE WHEN THE SUBMINIATURE/COMPACT TO MINIATURE PROBE TIP ADAPTER IS USED. (ITEM 4)		
-5	015-0325-01			1	ADAPTER,PROBE:PROBE TO CONNECTOR PINS	TK2565	015-0325-01
-6	013-0084-04			1	ADAPTER,CONN:BNC TO PROBE	80009	013-0084-04
-7	015-0201-07			1	TIP,PROBE:IC TEST,PKG OF 10	80009	015-0201-07
	015-0201-08			1	TIP,PROBE:IC TEST,PKG OF 100	80009	015-0201-08
-8	013-0085-00			1	TIP,PROBE:GROUNDING	80009	013-0085-00
-9	352-0670-00			1	HOLDER,PROBE:ATTENUATOR TIPS (3)	TK2565	352-0670-00
-10	196-3113-03			1	LEAD,ELECTRICAL:STRD,22 AWG,3.0 L,8-N	TK2469	196-3113-03
-11	352-0351-00			1	HOLDER,PROBE:BLACK ABS P6000 SERIES	7X318	1127
-12	016-0633-00			1	MARKER SET,CA:2 EA VARIOUS COLORS	80009	016-0633-00
-13	SMG50			1	SMT KLIPCHIP:20 ADAPTERS		
-14	016-1077-00			1	ACCESSORY KIT:GND TIP CONTACT,PKG OF 2 EA OF 5 LENGTHS W/COVER SHELL	80009	016-1077-00
-15	013-0254-00	9307		1	ADAPTER,CONN:BNC TO PROBE TIP,MALE	24931	28P-302-2
-16	131-5031-00	8926		1	CONNECTOR,PROBE:PKG OF 25,COMPACT	8009	131-5031-00



**Manufacturers cross index**

<b>Mfr. code</b>	<b>Manufacturer</b>	<b>Address</b>	<b>City, state, zip code</b>
0J260	COMTEK MANUFACTURING OF OREGON	P O BOX 4200 M/S 16-207	BEAVERTON, OR 970764200
24931	BERG ELECTRONICS INC	BERG ELECTRONICS RF/COAXIAL DIV 2100 EARLYWOOD DR PO BOX 547	FRANKLIN, IN 46131
7X318	KASO PLASTICS INC	11013 A NE 39TH	VANCOUVER, WA 98662
80009	TEKTRONIX INC	14150 SW KARL BRAUN DR PO BOX 500	BEAVERTON, OR 97077-0001
TK2469	UNITREK CORPORATION	3000 LEWIS & CLARK HWY SUITE 2	VANCOUVER, WA 98661
TK2548	XEROX CORPORATION	14181 SW MILLIKAN WAY	BEAVERTON, OR 97005
TK2565	VISION PLASTICS INC	26000 SW PARKWAY CENTER DRIVE	WILSONVILLE, OR 97070