



ABN 43 064 478 842

231 Osborne Avenue Clayton South, VIC 3169  
PO Box 1548, Clayton South, VIC 3169  
t 03 9265 7400 f 03 9558 0875  
freecall 1800 680 680  
www.tmgtestequipment.com.au

## Test & Measurement

- > sales
- > rentals
- > calibration
- > repair
- > disposal

## Complimentary Reference Material

This PDF has been made available as a complimentary service for you to assist in evaluating this model for your testing requirements.

TMG offers a wide range of test equipment solutions, from renting short to long term, buying refurbished and purchasing new. Financing options, such as Financial Rental, and Leasing are also available on application.

TMG will assist if you are unsure whether this model will suit your requirements.

Call TMG if you need to organise repair and/or calibrate your unit.

If you click on the "Click-to-Call" logo below, you can call us for FREE!

TMG Corporate Website

TMG Products Website



Click-to-Call  
TMG Now



Product Lifecycle Management System

### Disclaimer:

All trademarks appearing within this PDF are trademarks of their respective owners.



# **User Manual**

**Tektronix**

**P7260**

**6 GHz 5X/25X Active Probe**

**071-0922-02**

Copyright © Tektronix, Inc. All rights reserved.

Tektronix products are covered by U.S. and foreign patents, issued and pending. Information in this publication supercedes that in all previously published material. Specifications and price change privileges reserved.

Tektronix, Inc., P.O. Box 500, Beaverton, OR 97077

TEKTRONIX, TEK, and TekConnect are registered trademarks of Tektronix, Inc.

## WARRANTY

Tektronix warrants that the products that it manufactures and sells will be free from defects in materials and workmanship for a period of one (1) year from the date of shipment. If a product proves defective during this warranty period, Tektronix, at its option, either will repair the defective product without charge for parts and labor, or will provide a replacement in exchange for the defective product.

In order to obtain service under this warranty, Customer must notify Tektronix of the defect before the expiration of the warranty period and make suitable arrangements for the performance of service. Customer shall be responsible for packaging and shipping the defective product to the service center designated by Tektronix, with shipping charges prepaid. Tektronix shall pay for the return of the product to Customer if the shipment is to a location within the country in which the Tektronix service center is located. Customer shall be responsible for paying all shipping charges, duties, taxes, and any other charges for products returned to any other locations.

This warranty shall not apply to any defect, failure or damage caused by improper use or improper or inadequate maintenance and care. Tektronix shall not be obligated to furnish service under this warranty a) to repair damage resulting from attempts by personnel other than Tektronix representatives to install, repair or service the product; b) to repair damage resulting from improper use or connection to incompatible equipment; c) to repair any damage or malfunction caused by the use of non-Tektronix supplies; or d) to service a product that has been modified or integrated with other products when the effect of such modification or integration increases the time or difficulty of servicing the product.

**THIS WARRANTY IS GIVEN BY TEKTRONIX IN LIEU OF ANY OTHER WARRANTIES, EXPRESS OR IMPLIED. TEKTRONIX AND ITS VENDORS DISCLAIM ANY IMPLIED WARRANTIES OF MERCHANTABILITY OR FITNESS FOR A PARTICULAR PURPOSE. TEKTRONIX' RESPONSIBILITY TO REPAIR OR REPLACE DEFECTIVE PRODUCTS IS THE SOLE AND EXCLUSIVE REMEDY PROVIDED TO THE CUSTOMER FOR BREACH OF THIS WARRANTY. TEKTRONIX AND ITS VENDORS WILL NOT BE LIABLE FOR ANY INDIRECT, SPECIAL, INCIDENTAL, OR CONSEQUENTIAL DAMAGES IRRESPECTIVE OF WHETHER TEKTRONIX OR THE VENDOR HAS ADVANCE NOTICE OF THE POSSIBILITY OF SUCH DAMAGES.**



# Table of Contents

General Safety Summary .....	v
<b>Preface</b> .....	<b>vii</b>
Related Manuals .....	vii
Manual Structure .....	vii
Manual Conventions .....	viii
Contacting Tektronix .....	ix
<b>Product Description</b> .....	<b>1</b>
Options .....	2
TekConnect Interface .....	2
Installation .....	3
Firmware Requirements .....	3
Probe Installation .....	3
LED Flashes .....	4
Changing Probe Attenuation .....	5
Cleaning .....	6
<b>Features and Accessories</b> .....	<b>7</b>
<b>Host Instrument-to-Probe Calibration</b> .....	<b>19</b>
<b>Functional Check</b> .....	<b>21</b>
<b>Configuration</b> .....	<b>23</b>
Probe Offset .....	23
<b>Operating Basics</b> .....	<b>25</b>
Handling the Probe .....	25
Maximum Nondestructive Input Voltage .....	25
Input Linear Dynamic Range .....	26
Electrical Effects of Ground Lead Length .....	26
Ground Lead Inductance .....	27
Electrical Effects of Adapters .....	29
<b>Troubleshooting</b> .....	<b>31</b>
Nontypical LED Flash Pattern When You Install the Probe ...	31
Nontypical LED Response When You Press the SELECT Button .....	32

## Table of Contents

---

<b>Specifications</b> .....	<b>33</b>
Warranted Characteristics .....	33
Typical Characteristics .....	34
<b>Replaceable Parts</b> .....	<b>41</b>
Parts Ordering Information .....	41
Using the Replaceable Parts List .....	42
Item Names .....	42
Indentation System .....	42
Abbreviations .....	42

## List of Figures

<b>Figure 1: P7260 Probe featuring the TekConnect interface</b>	<b>1</b>
<b>Figure 2: Connecting and disconnecting the probe</b> .....	<b>4</b>
<b>Figure 3: Probe functional check connections</b> .....	<b>20</b>
<b>Figure 4: Dynamic and offset limitations</b> .....	<b>24</b>
<b>Figure 5: Waveform distortion from ground lead length</b> ..	<b>27</b>
<b>Figure 6: Ground lead equivalent circuit</b> .....	<b>28</b>
<b>Figure 7: Typical effects of using the probe tip adapters</b> ...	<b>29</b>
<b>Figure 8: Typical input impedance and phase versus frequency</b> .....	<b>35</b>
<b>Figure 9: Typical bandwidth at 5X attenuation</b> .....	<b>36</b>
<b>Figure 10: Typical bandwidth at 25X attenuation</b> .....	<b>37</b>
<b>Figure 11: Probe head and compensation box dimensions</b> .	<b>38</b>
<b>Figure 12: P7260 replaceable parts</b> .....	<b>43</b>
<b>Figure 13: P7260 standard accessories</b> .....	<b>44</b>
<b>Figure 14: P7260 optional accessories</b> .....	<b>46</b>



# List of Tables

<b>Table 1: P7260 features and standard accessories</b> .....	<b>7</b>
<b>Table 2: P7260 optional accessories</b> .....	<b>16</b>
<b>Table 3: Nontypical LED flash patterns</b> .....	<b>31</b>
<b>Table 4: End states following nontypical LED flash patterns</b> .....	<b>32</b>
<b>Table 5: Warranted electrical specifications</b> .....	<b>33</b>
<b>Table 6: Typical electrical characteristics</b> .....	<b>34</b>
<b>Table 7: Typical mechanical characteristics</b> .....	<b>39</b>
<b>Table 8: Environmental characteristics</b> .....	<b>39</b>
<b>Table 9: Certifications and compliances</b> .....	<b>40</b>

# General Safety Summary

Review the following safety precautions to avoid injury and prevent damage to this product or any products connected to it. To avoid potential hazards, use this product only as specified.

*Only qualified personnel should perform service procedures.*

## To Avoid Fire or Personal Injury

**Connect and Disconnect Properly.** Connect the probe output to the measurement instrument before connecting the probe to the circuit under test. Disconnect the probe input and the probe ground from the circuit under test before disconnecting the probe from the measurement instrument.

**Observe All Terminal Ratings.** To avoid fire or shock hazard, observe all ratings and markings on the product. Consult the product manual for further ratings information before making connections to the product.

Connect the ground lead of the probe to earth ground only.

**Do Not Operate Without Covers.** Do not operate this product with covers or panels removed.

**Do Not Operate With Suspected Failures.** If you suspect there is damage to this product, have it inspected by qualified service personnel.

**Do Not Operate in Wet/Damp Conditions.**

**Do Not Operate in an Explosive Atmosphere.**

**Keep Product Surfaces Clean and Dry.**

## Safety Terms and Symbols

**Terms in This Manual.** These terms may appear in this manual:



---

**WARNING.** *Warning statements identify conditions or practices that could result in injury or loss of life.*

---



---

**CAUTION.** *Caution statements identify conditions or practices that could result in damage to this product or other property.*

---

**Terms on the Product.** These terms may appear on the product:

DANGER indicates an injury hazard immediately accessible as you read the marking.

WARNING indicates an injury hazard not immediately accessible as you read the marking.

CAUTION indicates a hazard to property including the product.

**Symbols on the Product.** These symbols may appear on the product:



CAUTION  
Refer to Manual



# Preface

This is the instruction manual for the P7260 6 GHz 5X/25X Active Probe. Read this preface to learn how this manual is structured and what conventions it uses. Before using this manual or the P7260 probe, read the *General Safety Summary* section at the beginning of this manual for safety and other important background information.

## Related Manuals

If you need to do a performance verification for your probe refer to the *P7260 6 GHz 5X/25X Active Probe Service Manual*. The manual is available as a printable .pdf file on the Application Software CD (Tektronix part number 063-3376-XX) that accompanies your host instrument, or on the Tektronix website.

## Manual Structure

This manual is divided into sections that contain related section topics:

- *Product Description* includes a product description, and instructions for installation and changing probe attenuation.
- *Features and Accessories* introduces the standard and optional accessories for the probe.
- *Operating Basics* includes information about handling the probe, dynamic range, and grounding.
- *Specifications* includes warranted electrical specifications, Typical electrical characteristics, and graphs for typical input impedance and typical bandwidth.

Be sure to read the introductory text for each procedure. These introductions provide important information needed to use the P7260 correctly, safely, and efficiently.

## Manual Conventions

This manual uses certain conventions that you should become familiar with before using the P7260 probe.

### **Safety**

Symbols and terms related to safety appear in the *General Safety Summary* found at the beginning of this manual.

## Contacting Tektronix

<b>Phone</b>	1-800-833-9200*
<b>Address</b>	Tektronix, Inc. Department or name (if known) 14200 SW Karl Braun Drive P.O. Box 500 Beaverton, OR 97077 USA
<b>Web site</b>	<a href="http://www.tektronix.com">www.tektronix.com</a>
<b>Sales support</b>	1-800-833-9200, select option 1*
<b>Service support</b>	1-800-833-9200, select option 2*
<b>Technical support</b>	<a href="http://www.tektronix.com/support">www.tektronix.com/support</a> 1-800-833-9200, select option 3* 6:00 a.m. - 5:00 p.m. Pacific Standard Time

---

\* **This phone number is toll free in North America. After office hours, please leave a voice mail message. Outside North America, contact a Tektronix sales office or distributor; see the Tektronix web site for a list of offices.**



# Product Description

The Tektronix P7260 is a 6 GHz active probe. It has a low input capacitance ( $<0.5$  pF) and high input resistance ( $20$  k $\Omega$  at DC), which minimize circuit loading over a wide bandwidth range.

The P7260 probe features selectable attenuation to maximize dynamic range and sensitivity. The 5X setting provides  $1.5$  V<sub>p-p</sub> dynamic range and  $<75$  ps risetime, and the 25X setting provides  $6$  V<sub>p-p</sub> dynamic range and  $<85$  ps risetime.

Designed for use with the TDS6604 TekConnect host instrument, the P7260 system bandwidth is typically 6 GHz at the probe tip. The TekConnect interface extends useful bandwidth and signal fidelity to 18 GHz.



**Figure 1: P7260 Probe featuring the TekConnect interface**



The small profile and low-mass head of the P7260 make probing dense circuitry by hand fast and easy. Complimentary accessory tips and adapters help you connect with a wide variety of circuit architectures. For hands-free probing, the square-pin adapter (standard accessory), and the PPM100, a multi-axis probe positioner (optional accessory) are provided. For details, refer to the *Features and Accessories* section of this manual.

## Options

The following options are available when ordering the P7260 probe:

- D1 Calibration data report
- C3 Additional 2 years of calibration
- D3 Calibration data report for Option C3
- R3 Additional 2 years of repair
- C5 Additional 4 years of calibration
- D5 Calibration data report for Option C5
- R5 Additional 4 years of repair

## TekConnect Interface

The P7260 is powered through a TekConnect interface between the probe compensation box and the host instrument. The TekConnect interface provides a communication path through contact pins on the host instrument. Power, signal, offset, and probe characteristic data transfer through the interface.

When the probe is connected, the host instrument reads configuration information from the probe, allowing the host instrument to optimally configure the internal signal path. To protect the preamp inputs on the host instrument from electrostatic discharge, the inputs remain grounded until a valid TekConnect device is detected.

## Installation

The P7260 connects directly to the TekConnect interface on the TekConnect host instrument.

### Firmware Requirements

To ensure compatibility of your TekConnect host instrument with the probe, your TDS7000, or CSA7000 series host instrument must have the firmware upgrade V2.1.0 or higher.

Firmware upgrade instructions are available on the Tektronix website at [www.tektronix.com](http://www.tektronix.com). Select the *Software & Drivers* link on the home page of the website. The Tektronix website provides up-to-date software and firmware upgrades for your P7260 and host instrument.

### Probe Installation

The TekConnect interface features a spring-loaded latch that provides audible and tactile confirmation that a reliable connection has been made to the host instrument. Slide the probe into the TekConnect receptacle on the host instrument. The probe snaps into the host instrument when fully engaged. See Figure 2 on page 4.

To release the probe from the host instrument, grasp the compensation box, depress the latch button, and pull out the probe.

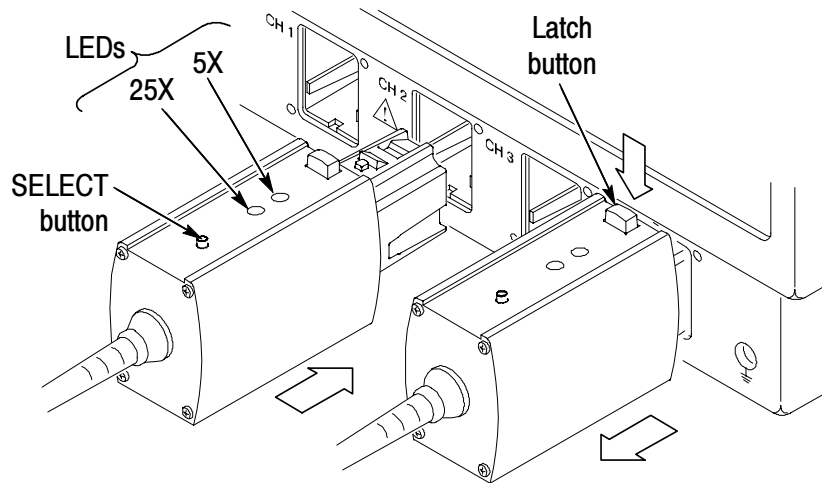

**Figure 2: Connecting and disconnecting the probe**

## LED Flashes

Two green LEDs, labeled 5X and 25X, are visible on the top of the P7260 compensation box. See Figure 2, above. When you connect the probe to a channel on the host instrument, the LEDs immediately show the following information:

- The results of diagnostic tests performed on internal circuitry of the probe. The tests include signals to the host instrument and a host response.
- The attenuation setting of the probe. Initially, the host instrument sets the attenuation of the probe to 25X.

### Reading LED diagnostic flashes

In normal operation when you connect the probe, both LEDs flash once, simultaneously. This flash indicates that the P7260 has completed internal diagnostics and is initiating communication with the host. Next, the 25X attenuation LED lights and remains lit, indicating that the host has recognized the P7260, configured internal signal paths accordingly, and set the default attenuation to 25X.

---

**NOTE.** *If you see a different set of flashes than described on page 4, the internal circuitry of the P7260 has failed in some way. To avoid inaccurate probing, do not use the probe before referring to page 32 of the Troubleshooting section.*

---

## Changing Probe Attenuation

Upon installation, the default attenuation of the P7260 is set to 25X.

To manually change attenuation, use the SELECT button located below the LED lights on the top of the compensation box. To switch to 5X attenuation, grasp the compensation box and depress the SELECT button. The 25X LED extinguishes and the 5X LED lights. To return to 25X attenuation, depress the SELECT button again.

You can also change attenuation settings using GPIB commands available on your host instrument. Refer to the GPIB Programmer Online Help software provided with your host instrument.

---

**NOTE.** *After connecting the P7260 to the host instrument, allow the probe to warm up for at least twenty minutes before probing.*

---

## Cleaning

Follow these guidelines for cleaning the P7260 probe.



---

**CAUTION.** *To avoid permanent damage from static or to avoid damage to the probe tip, do not clean the probe head or probe tip. While cleaning the compensation box and cable, use only enough solution to dampen the cloth or swab. No part of the P7260 is waterproof.*

---

**General Care.** Do not use chemical cleaning agents. Do not use chemicals that contain acetone, benzene, toluene, xylene, or similar solvents because they will damage the plastic.

Clean the exterior surfaces of the compensation box with a dry, lint-free cloth or a soft-bristle brush. If dirt remains, use a cloth or swab dampened with a 75% isopropyl alcohol solution. A swab is useful for cleaning in narrow spaces around the TekConnect release button and connectors. Do not use abrasive compounds on any part of the instrument.

# Features and Accessories

The P7260 has several features and accessories designed to make probing and measurement a simpler task. To familiarize yourself with these items and their uses, refer to Table 1. Refer to Table 2 on page 16 for descriptions of optional accessories that you can order.

**Table 1: P7260 features and standard accessories**

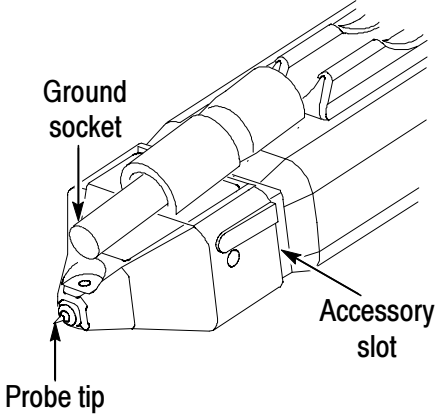
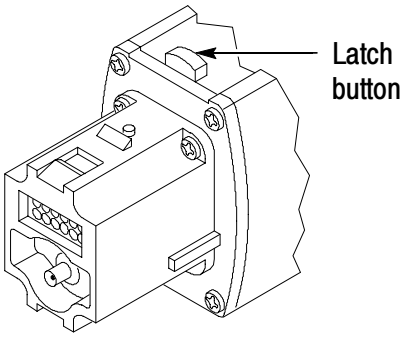
Feature/Accessory	Description
 <p>A perspective view of the probe head assembly. Labels with arrows point to the 'Ground socket' at the top, the 'Probe tip' at the bottom, and the 'Accessory slot' on the side.</p>	<p><b>Probe head assembly.</b> The probe head is designed for ease of use and high performance. The small size makes it easy to handle in tight areas.</p> <p>The probe head features a slot that is designed for holding accessories in place.</p> <p>The nominal distance between the probe tip and the ground socket is .083 inches.</p>
 <p>A perspective view of the TekConnect interface. A label with an arrow points to the 'Latch button' on the top surface.</p>	<p><b>TekConnect interface.</b> The TekConnect interface provides a communication path between the probe and the host instrument. Contact pins provide power, signal, offset, and probe characteristic data transfer.</p> <p>The probe snaps into the host instrument when fully engaged. To remove, grasp the compensation box, depress the latch button, and pull the probe out.</p>

**Table 1: P7260 features and standard accessories (Cont.)**

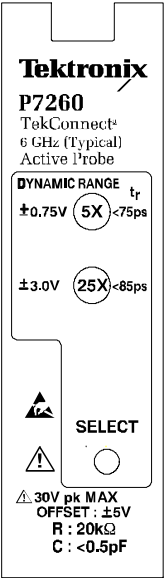
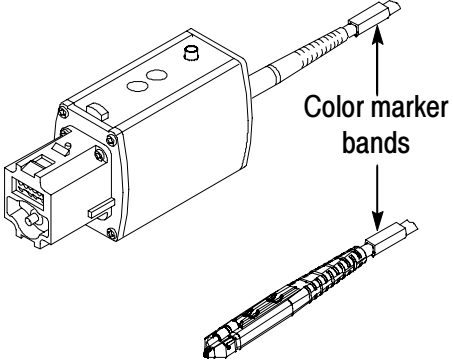
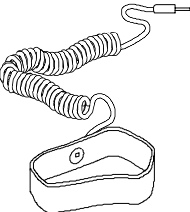
Feature/Accessory	Description
	<p><b>Attenuation selector.</b> The P7260 probe features 5X and 25X attenuation settings. Green LED indicators, labeled 5X and 25X, are visible on the top of the compensation box. When a setting is selected, the LED beside it lights.</p> <p>When you connect the probe to a host instrument, attenuation is automatically set to 25X. To switch settings while probing, firmly press the SELECT button. The 25X LED extinguishes and the 5X LED lights.</p> <p>These LED lights also display diagnostic information about the probe. Refer to page 4 of the <i>Product Description</i> section for more information about the LED lights.</p>
	<p><b>Color marker bands.</b> When you are using more than one probe, the bands enable you to quickly match the probes to the channels that they are connected to.</p> <p>To use the marker bands, attach a band to the probe cable near the probe head and near the probe compensation box. Use the color band that matches the color of the channel that the probe is connected to.</p> <p>Tektronix part number: 016-1886-XX (1 set)</p>
	<p><b>Antistatic wrist strap.</b> When using the probe, always work at an antistatic work station and wear the antistatic wrist strap.</p> <p>Tektronix part number: 006-3415-XX</p>

**Table 1: P7260 features and standard accessories (Cont.)**

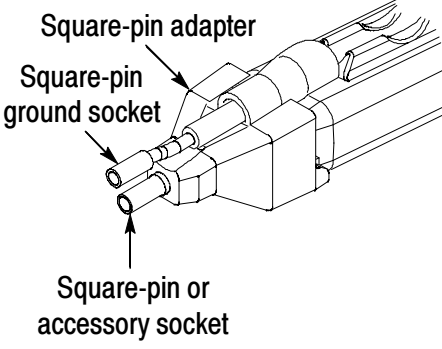
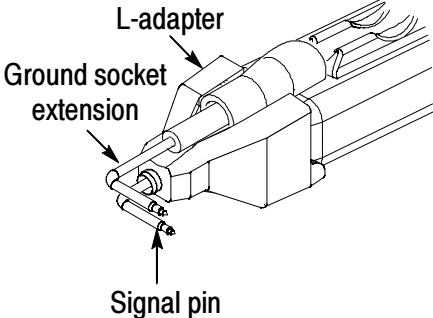
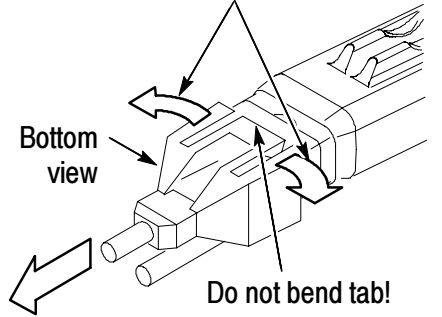
Feature/Accessory	Description
	<p><b>Square-pin adapter.</b> This adapter has a socket for holding a square-pin, or an adapter such as the SureToe, SMT KlipChip, or Y-lead adapter. A square pin ground socket extension that you insert into the ground socket of the probe is included. These sockets can accept .100 in. or .080 in. centered square pins.</p> <p>To attach the square-pin adapter, hold it between your thumb and forefinger and gently slip it over the probe head until the accessory slot on the probe head holds the adapter in place.</p> <p>Tektronix part number: 016-1910-XX (1 set)</p>
	<p><b>L-adapter.</b> This adapter enables you to probe and ground at right angles to the device under test (DUT), while holding the probe parallel to the DUT. A ground socket extension that you insert into the ground socket of the probe is included.</p> <p>To attach the L-adapter, hold it between your thumb and forefinger and gently slip it over the probe head until the accessory slot on the probe head holds the adapter in place.</p> <p>Tektronix part number: 016-1913-XX (1 set)</p>
<p>Gently rock the adapter side-to-side as you pull the adapter straight off</p> 	<p><b>Removing the Square-pin and L-Adapters.</b></p> <p>Caution! The Square-pin and L-adapters have a tab on the bottom side of the probe. (See illustration). When you remove these adapters, do not bend the tab, otherwise you will break the tab.</p> <p>To safely disengage the adapter from the probe tip, grasp the sides of the adapter (not the tab), and gently rock the adapter side-to-side as you pull the adapter straight off of the probe.</p>

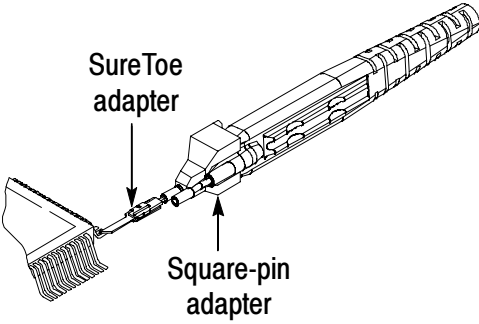
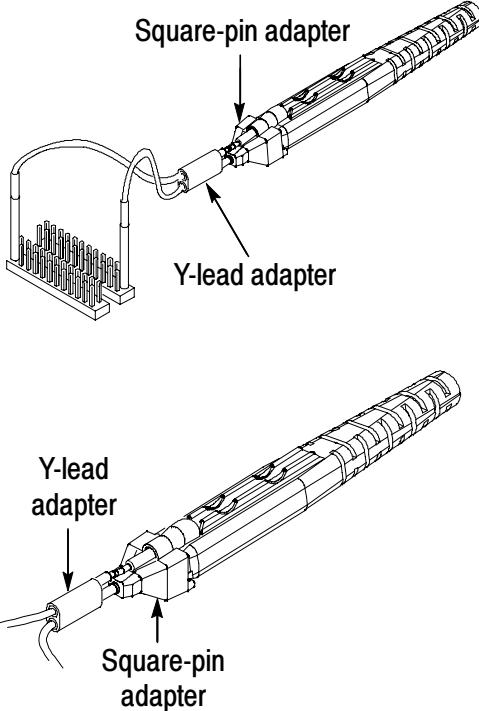

**Table 1: P7260 features and standard accessories (Cont.)**

Feature/Accessory	Description
	<p><b>SureToe adapter (4 ea).</b> The SureToe adapter is a pointed probe tip useful for probing in IC legs.</p> <p>Mount the SureToe adapter in the signal pin socket of the Square-pin adapter. Attach the SureToe adapter the same way as you attach the push-in probe tips. This adapter can be used with any of the socketed accessory leads.</p> <p>Tektronix part number: ST501 (package of 12)</p>
	<p><b>Y-lead adapter.</b> Use the Y-lead adapter to extend the physical reach of the probe and ground when necessary. The Y-lead adapter accepts any of the probe tips or adapters, and can be pushed directly onto the Square-pin adapter.</p> <p>When selecting the grounding connection, maintain as short a ground path as possible. Refer to page 26 for more grounding information.</p> <p>To attach the Y-lead adapter, gently press the lead pins into the signal and ground sockets of the Square-pin adapter.</p> <p>Using the black lead for ground is recommended.</p> <p>Tektronix part number 196-3434-XX (1 each)</p>

**Table 1: P7260 features and standard accessories (Cont.)**

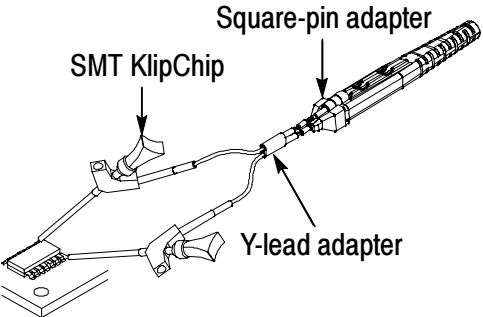
Feature/Accessory	Description
 <p>The diagram illustrates the assembly of an SMT KlipChip. It shows a Square-pin adapter connected to a Y-lead adapter, which is then connected to the SMT KlipChip. The SMT KlipChip has a flexible sleeve and clips. Labels with arrows point to the 'Square-pin adapter', 'SMT KlipChip', and 'Y-lead adapter'.</p>	<p><b>SMT KlipChip.</b> Use the clips of the SMT KlipChip to access fragile, dense circuitry.</p> <p>To use SMT KlipChips with the probe, connect the Square-pin adapter to the probe head. Plug the KlipChips into the Y-lead adapter, and then connect the Y-lead adapter to the Square-pin adapter.</p> <p>The SMT KlipChip body turns freely, allowing better probe orientation. To reduce stress and provide a low profile on components being tested, the flexible sleeve of the SMT KlipChip bends up to a 35 degree angle.</p> <p>Tektronix part number: 206-0364-XX (1 each)</p>

**Table 1: P7260 features and standard accessories (Cont.)**

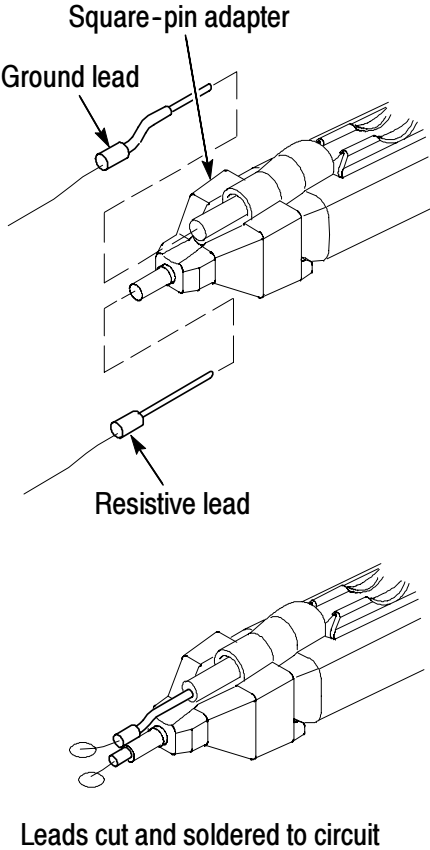
Feature/Accessory	Description
 <p>Square-pin adapter</p> <p>Ground lead</p> <p>Resistive lead</p> <p>Leads cut and soldered to circuit</p>	<p><b>Solderable resistive lead and ground lead.</b></p> <p>These two accessory leads provide a convenient way for you to make hands-free, soldered probe connections to your circuit. The 22 <math>\Omega</math> resistive leads damp the measured signal for best fidelity. Use these leads with the Square-Pin Adapter.</p> <p>To use the leads, plug the Square-Pin Adapter onto the probe and locate the probe next to your test point to gauge how short to cut the leads. The leads will not support the weight of the probe, so make sure that you can secure the probe without straining the connections.</p> <p>Next, measure both the resistive lead (signal) and ground lead, and cut the leads as short as possible to connect to your circuit, preferably less than 0.100 in.</p> <p>Insert the large-diameter lead of the resistive lead into the signal socket of the Square-Pin Adapter, and plug the gold pin of the ground lead into the ground socket. Solder the small diameter leads to your circuit and secure the probe.</p> <p>Solderable Resistive Lead Tektronix part number: 196-3493-XX (1 set of 8)</p> <p>Solderable Ground Lead Tektronix part number: 196-3495-XX (1 set of 8)</p>

**Table 1: P7260 features and standard accessories (Cont.)**

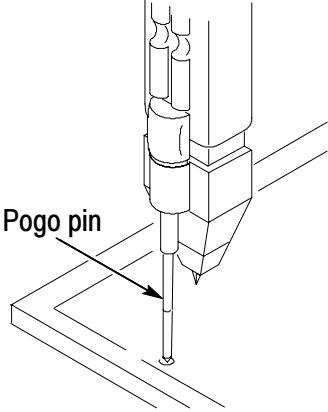
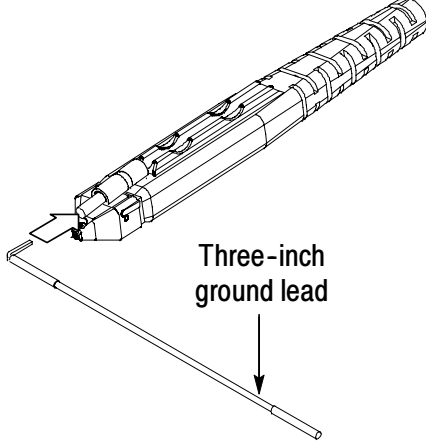
Feature/Accessory	Description
	<p><b>Short ground pogo pin.</b>            This pogo ground pin has a flexible reach of .070 to 1.00 inches and a .083 inch nominal distance between the probe tip and the ground socket. The pin retracts when pressure is applied.</p> <p>When a short ground is required for probing, insert the pogo pin into the ground socket of the probe or adapter.</p> <p>When selecting the grounding connection, maintain as short a ground path as possible. Refer to page 26 for more grounding information.</p> <p>Tektronix part number: 016-1917-XX (1 set)</p>
	<p><b>Three-inch ground lead.</b> Use the three-inch ground lead for general probing. The socketed end of the lead may be connected to any of the probe tips and adapters or fitted onto 0.025 inch square pins.</p> <p>To attach the ground lead, press and rotate the lead pin connector into the ground socket on the probe head. The lead may be removed by simply pulling the pin out by hand.</p> <p>When selecting the grounding connection, maintain as short a ground path as possible. Refer to page 26 for more information.</p> <p>Tektronix part number: 196-3437-10 (1 set)</p>

**Table 1: P7260 features and standard accessories (Cont.)**

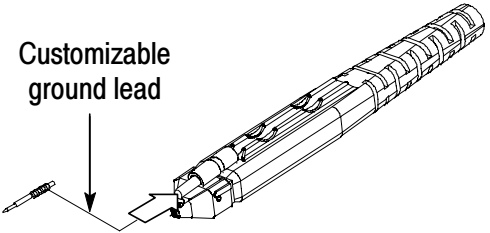
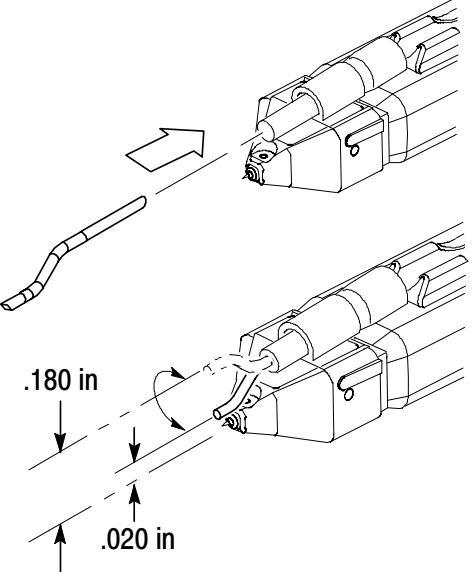
Feature/Accessory	Description
	<p><b>Customizable ground lead.</b> This ground lead wire can be bent or cut shorter.</p> <p><b>NOTE:</b> To ease insertion into the ground socket of the probe, cut the tip of this ground lead wire at a 30 to 60 degree angle.</p> <p>To maintain signal fidelity while probing, use as short a ground path as possible. Refer to page 26 for more grounding information.</p> <p>This accessory is not intended for use with the Square-pin adapter (Tektronix part number: 016-1910-XX).</p> <p>Tektronix part number: 196-3482-XX (1 set)</p>
	<p><b>Z lead.</b> Use the Z lead to ground the probe when the distance between the DUT test point and ground is greater or less than about 0.100 in. (the fixed distance between the probe tip and probe ground).</p> <p>You can rotate the Z-lead in the probe ground socket to accommodate distances of approximately 0.020 to 0.180 in.</p> <p>Tektronix part number: 196-3491-XX (1 set)</p>

**Table 1: P7260 features and standard accessories (Cont.)**



Feature/Accessory	Description
	<p><b>Plastic accessory box.</b> Use the plastic box to store the probe accessories when not in use.</p> <p>Tektronix part number: 006-7164-XX</p>
	<p><b>Instrument case.</b> The instrument case protects the probe from harsh environments and provides room for storing optional accessories.</p> <p>Tektronix part number: 016-1879-XX</p>
	<p><b>Instruction Manual.</b> Provides instructions for efficiently operating the probe, descriptions of accessories for the probe, and procedures for verifying the performance of the probe.</p> <p>Tektronix part number: 071-0922-XX</p>
	<p><b>Calibration certificate.</b> A certificate of traceable calibration is provided with every instrument shipped.</p>
	<p><b>Accessory reorder sheet.</b> The accessory reorder sheet provides photos and part numbers for identifying standard and optional accessories that are compatible with your probe.</p> <p>Tektronix part number: 001-1349-XX</p>

Table 2 lists the optional accessories you can order for your P7260 probe.

**Table 2: P7260 optional accessories**

Accessory	Description
 <p>The image shows an IC Grabber, which is a small metal tool with two thin, pointed probes extending from a base. It is used for probing surface-mounted integrated circuits.</p>	<p><b>IC Grabber.</b> Use the IC Grabber to probe the leads on integrated circuits that are surface-mounted.</p> <p>Tektronix part number: SMK4 (2 sets of 2)</p>
 <p>The image shows the TekConnect interface calibration fixture, which consists of a rectangular metal box with a cable attached to one side and a connector on the other.</p>	<p><b>TekConnect interface calibration fixture.</b> The calibration fixture is required when a performance verification or adjustment is done on the probe. It provides connectors and test points for internal probe measurements.</p> <p>Tektronix part number: 067-0422-XX</p>
 <p>The image shows the probe calibration fixture with labels: 'SMA connector' pointing to the top right, 'Probe holder' pointing to the main body, and '50 Ω Termination' pointing to a component on the bottom left.</p>	<p><b>Probe calibration fixture.</b> Use this calibration fixture to connect the probe to SMA cables. The fixture includes a removable 50 Ω terminator. The calibration fixture is required when performance verification is done for the probe.</p> <p>Tektronix part number: 067-1456-XX</p>
 <p>The image shows the PPM100 Probe Positioner, a complex mechanical device with a long, flexible arm and a heavy-duty base, used for precise probe positioning.</p>	<p><b>PPM100 Probe Positioner.</b> A general-purpose benchtop probe holder with flexible arm, designed for hands-free probing and fine positioning adjustments. The heavy duty base can be replaced with the clamp for securing the probe arm in a variety of situations. Use flexible retention rings to attach the probe to the probe holder.</p>

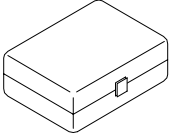
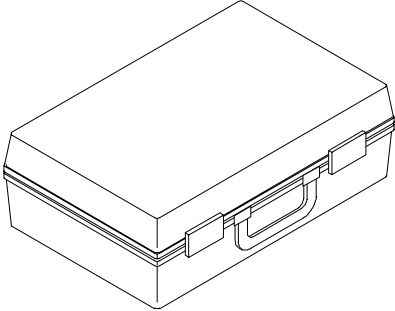
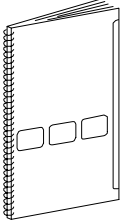
**Table 2: P7260 optional accessories (Cont.)**

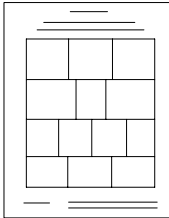
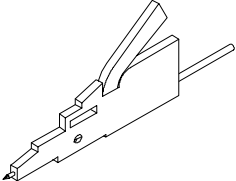
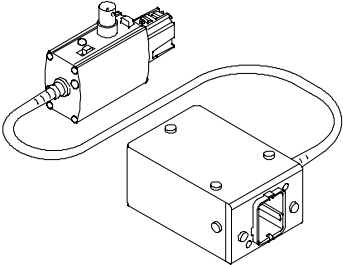
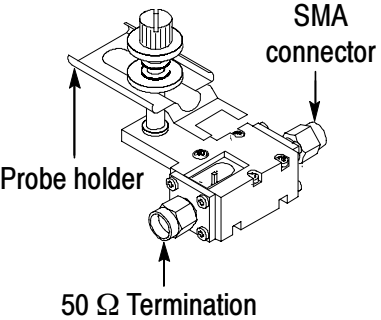
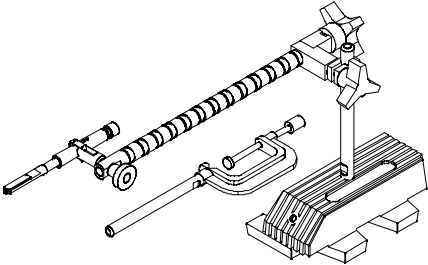
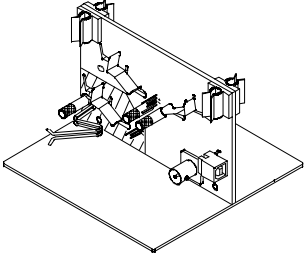
Accessory	Description
	<p><b>Deskew fixture.</b> This fixture provides a standalone edge source to time align (deskew) and to optimize host instrument gain and offset accuracy at the probe tip. You can deskew up to six probes simultaneously with the deskew fixture.</p> <p>Tektronix part number: 679-0484-XX</p>





# Host Instrument-to-Probe Calibration

Before using your probe with a new host instrument, perform a calibration for each channel that you will be using. This procedure calibrates both 5X and 25X attenuation paths at the same time. After an initial calibration, perform a probe calibration at user-defined or six-month intervals.

**Required Equipment.** Gather the following equipment:

- The P7260 probe
- Square-pin adapter with ground socket extension, supplied with the probe
- Y-lead adapter, supplied with the probe
- Two SMT KlipChips, supplied with the probe

---

**NOTE.** *Always use an antistatic wrist strap (provided with your probe), and work at a static-approved workstation when handling the probe.*

---

**Test Equipment Setup.** Do the following:

1. Connect the P7260 to a channel on your host instrument.
2. Set the host instrument to display the probe channel.
3. Connect the Square-pin adapter to the probe head. Plug the SMT KlipChips into the Y-lead adapter, and then connect the Y-lead adapter to the ground and pin sockets of the square-pin adapter. Refer to Figure 3 on page 20.
4. Connect the SMT KlipChips to the ground and signal connections of the PROBE COMPENSATION on the host instrument.

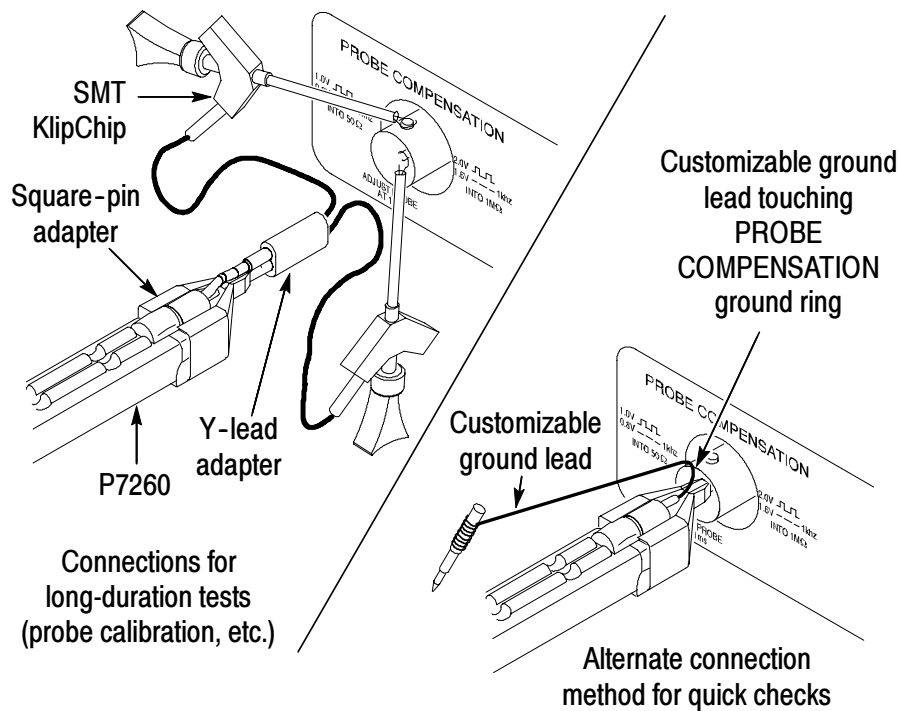

**Figure 3: Probe functional check connections**

---

**NOTE.** See your host instrument manual or online help for specific instructions on its operation.

---

**Test Procedure.** Do the following:

1. From the Vertical menu, select Probe Cal. A probe calibration panel displays on the right side of the screen.
2. Select the signal channel that the probe is connected to.
3. Choose Calibrate Probe. This operation may take several minutes. Do not remove the probe during this operation.
4. When probe calibration is complete, the Probe Status field reads either Pass or Fail. If the field reads Fail, contact your Tektronix service center.
5. Close the probe calibration panel.

# Functional Check

Perform a functional check to verify that a probe is functioning properly. Perform this check for each host instrument channel you will use for probing.

---

**NOTE.** *If not already done, perform a host instrument-to-probe calibration routine before performing this functional check. Refer to page 19 of the Host Instrument-to-Probe Calibration section.*

---

When you do a performance verification for your probe refer to the *P7260 6 GHz 5X/25X Active Probe Service Manual*. The manual is available as a printable .pdf file on the Application Software CD (Tektronix part number 063-3376-XX) that accompanies your host instrument, or on the Tektronix website.

**Required Equipment.** Gather the following equipment:

- The P7260 probe
- Square-pin adapter with ground socket extension, supplied with the probe
- Y-lead adapter, supplied with the probe
- Two SMT KlipChips, supplied with the probe

---

**NOTE.** *Always use an anti-static wrist strap (provided with your probe), and work at a static-approved workstation when handling the probe.*

---

**Test Equipment Hookup.** Do the following:

1. Connect the P7260 to a channel on your host instrument.
2. Set the host instrument to display the probe channel.
3. Connect the square-pin adapter to the probe head, and then connect the Y-lead adapter to the ground and pin sockets of the

square-pin adapter. Plug the SMT KlipChips into the Y-lead adapter. Refer to Figure 3 on page 20 of the *Host Instrument-to-Probe Calibration* section.

4. Connect the SMT KlipChips to the ground and signal connections of the PROBE COMPENSATION on the host instrument.

---

**NOTE.** See your host instrument manual or online help for specific instructions on its operation and offset control.

---

**Test Procedure.** Do the following:

1. Set the probe to 5X attenuation.
2. Press AUTOSSET, or adjust the host instrument to display a stable calibration waveform. (You may need to adjust the offset to display the waveform.)

Result: The square wave on the host instrument screen should match the signal measurements printed beside the PROBE COMPENSATION channel on the front panel.

3. Disconnect the SMT KlipChips from the PROBE COMPENSATION and connect the two KlipChips together.
4. Use the Offset knob located on the host instrument panel to set the probe offset to 0.0 V/div. Ensure that the host instrument display is at ground reference.
5. Use the Vertical Scale knob to set the vertical display of the host instrument to 2 V/div.
6. Change the attenuation of the probe to 25X.
7. Set the probe offset to -5.0 V (-4.9995 V). The signal will move to 5.0 V (2.5 divisions above ground reference).
8. Set the probe offset to 5.0 V (4.9995 V). The signal will move to -5.0 V (2.5 divisions below ground reference).

# Configuration

The P7260 provides the host instrument with the probe model number, serial number, and attenuation factor. When connected to a host instrument with a TekConnect interface, display readouts are corrected for the probe attenuation factor, the instrument input is set to 50  $\Omega$ , and the coupling is set to DC. The probe offset control is controlled by the host instrument.

## Probe Offset

The probe offset is adjustable to permit operation within the linear range of the probe. Using the offset to cancel DC signal components enables optimal probe performance. See Figure 4 on page 24 for more information.

---

**NOTE.** See your host instrument manual for specific instructions on its operation and offset control.

---

To set the probe offset, follow these steps:

1. Ground the input of the probe.
2. Use the vertical position control to set a zero reference level on the host instrument display.
3. Set the host instrument to 1 V/div.
4. Attach the probe to the test circuit.
5. Adjust the probe offset to bring the trace to the host instrument zero reference.
6. Change the V/div setting to the desired range, adjusting the offset to keep the trace on the zero reference level.

**NOTE.** The P7260 has a  $\pm 5.0$  V offset range which can be measured in 5X or 25X gain using offset.

The linear operating range at 5X is  $\pm 0.75$  V. The linear operating range at 25X is  $\pm 3.0$  V. See Figure 4, below.

If cursors are used on a TekConnect interface host instrument, the zero reference will be at the probe offset voltage.

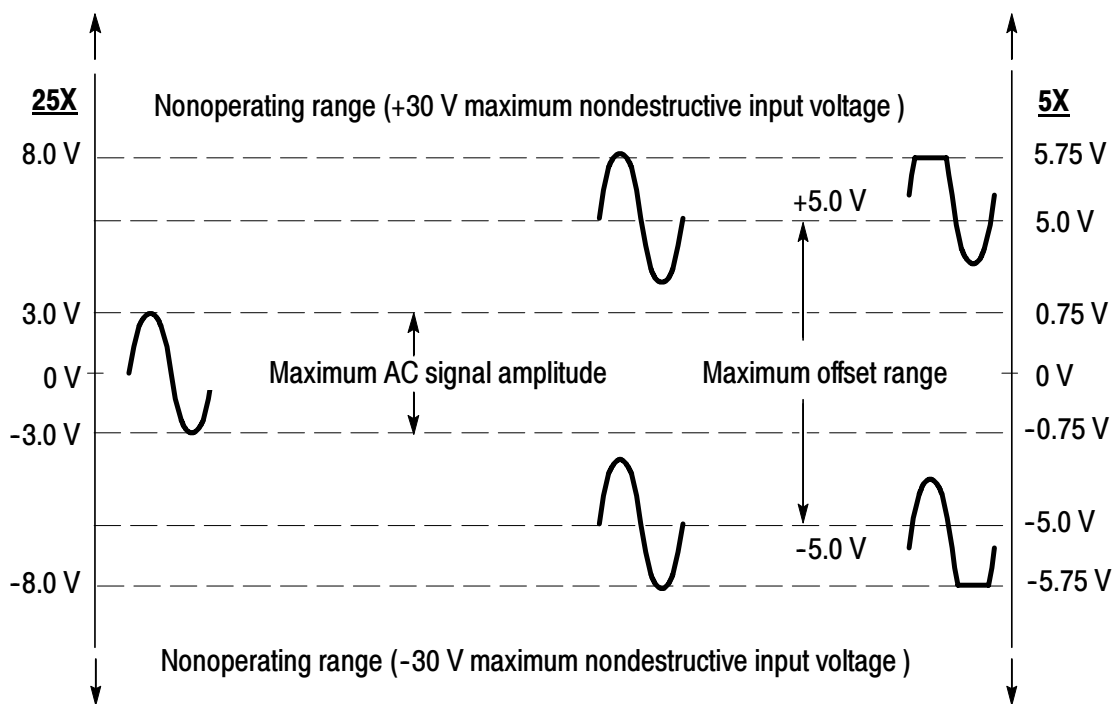

**Figure 4: Dynamic and offset limitations**

**NOTE.** To avoid signal degradation and inaccurate measurements, do not measure signals beyond the dynamic range specified for the attenuation setting you are using. Refer to Table 6 on page 34 of the Specifications section.

# Operating Basics

Please follow these operating guidelines to get optimum performance from your P7260 probe.

## Handling the Probe

Exercise care when using and storing the P7260. The probe and cable are susceptible to damage caused by careless use.

**Handling.** Always handle the probe using the compensation box and probe head, avoiding undue physical strain to the probe cable, such as kinking, excessive bending, or pulling. Visible dents in the cable will increase signal aberrations. Do not drop the probe or subject it to physical shock. Damage to the probe may result.



---

**CAUTION.** *To avoid breakage of the wires encased in the probe cable or the wires entering the probe head, do not tightly coil the cable for storage. Use the 6 inch cable reel provided in the probe case, or make a coil 6 inches or more in diameter.*

---



**Electrostatic Discharge (ESD).** The P7260 is sensitive to electrostatic discharge. When handling the probe, always wear an antistatic wrist strap (provided with your probe), and plug the wrist strap into the ground terminal available on your host instrument or static-approved workstation.

## Maximum Nondestructive Input Voltage

The P7260 is electrically protected against static voltage; however, applying voltages above its design limits may damage the probe tip amplifier. Refer to Table 6 in the *Specifications* for the maximum operating voltage.



## Input Linear Dynamic Range

The P7260 has two attenuation settings that affect dynamic range. Refer to instructions for manually changing attenuation of the probe, or use the GPIB commands available on your host instrument.

The probe head amplifier that the P7260 uses has a limited linear operating range. Refer to Table 6 in the *Specifications* section for dynamic range and linearity limits.

Use the DC offset adjustment to maintain the probe within the dynamic range. Refer to Table 6 in the *Specifications* section for the nominal offset adjustment range of the P7260.

---

**NOTE.** *The probe can tolerate input voltages of  $\pm 30$  V without damage; however, the linearity error specification does not apply to input voltages exceeding the dynamic range and offset range adjustment range. See Figure 4 on page 24.*

---

## Electrical Effects of Ground Lead Length

When you are probing a circuit, always use as short a ground lead as possible between the probe head and circuit ground.

The series inductance added by the probe tip and ground lead can result in a resonant circuit; this circuit may cause parasitic ringing within the bandwidth of your host instrument. Refer to Figure 5 on page 27.

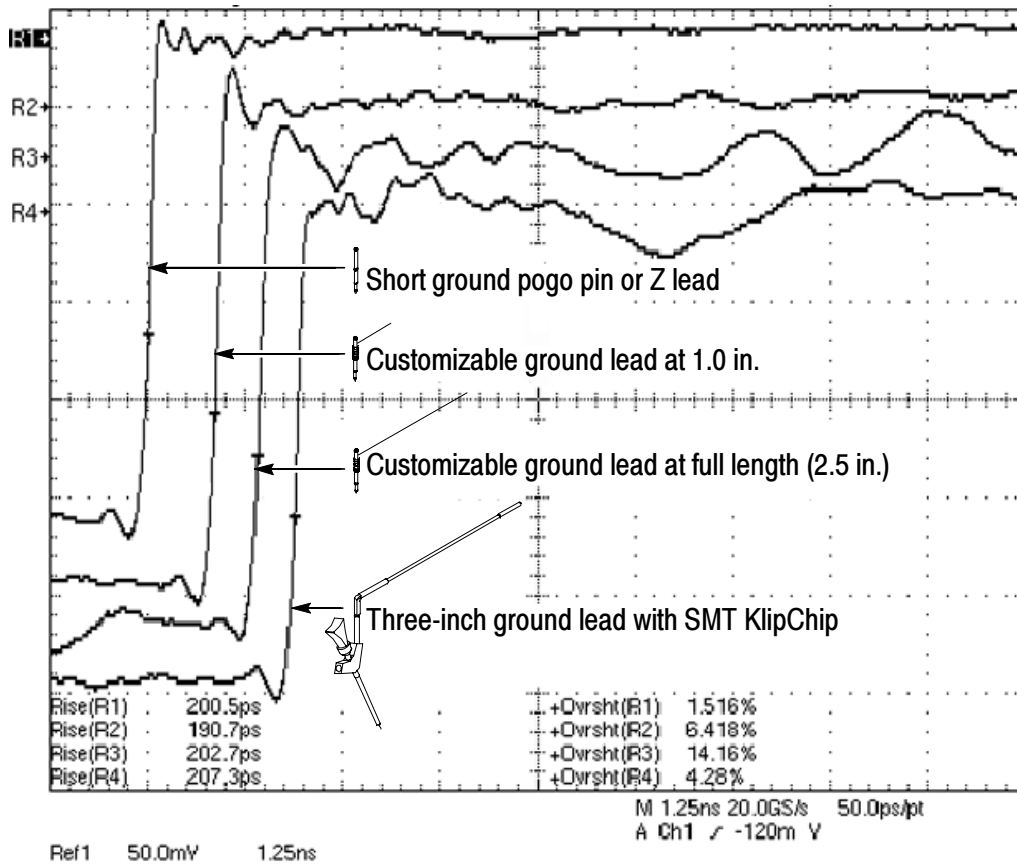

**Figure 5: Waveform distortion from ground lead length**

### Ground Lead Inductance

When you touch the probe tip to a circuit element, you are introducing a new resistance, capacitance, and inductance into the circuit. Refer to Figure 6 on page 28.

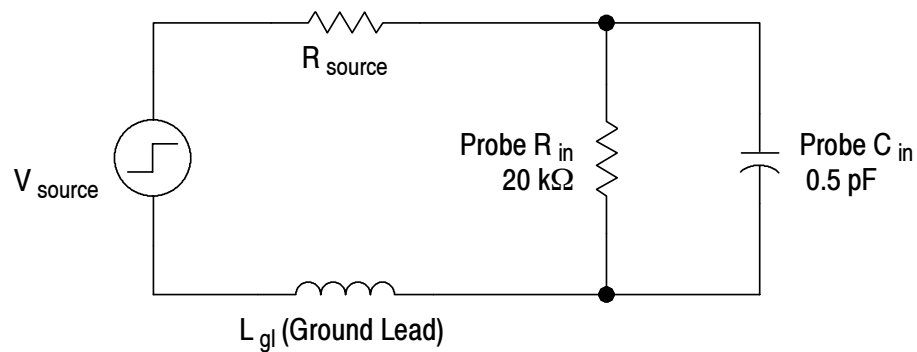

**Figure 6: Ground lead equivalent circuit**

Ringings and rise time degradation can be masked if the frequency content of the signal degradation is beyond the bandwidth of the host instrument.

You can determine if ground lead effects may be a problem in your application if you know the self-inductance ( $L$ ) and capacitance ( $C$ ) of your probe and ground lead. Calculate the approximate resonant frequency ( $f_0$ ) at which this parasitic circuit will resonate with the following formula:

$$f_0 = \frac{1}{2\pi \sqrt{LC}}$$

The preceding equation shows that reducing the ground lead inductance will raise the resonant frequency. If your measurements are affected by ringing, your goal is to lower the inductance of your ground path until the resulting resonant frequency is well above the frequency of your measurements.

The low-inductance ground contacts, described in *Features and Accessories* starting on page 7, can help you reduce the effects of ground lead inductance on your measurements.

## Electrical Effects of Adapters

The probe tip adapters included with your probe help connect to different types of components. While these adapters make connections easier, be aware that the adapter you choose may affect the signal you are measuring, depending on a variety of factors, including signal frequency, source impedance, and lead length.

Use the probe without adapters to optimize step and frequency response. Using the probe tip adapters adds inductance and capacitance, which increases step response and aberrations, and leads to increased ripples in frequency response. These effects increase as the source impedance increases and measured waveform risetimes decrease.

Figure 7 illustrates the typical effects on a given signal using some of the adapters included with your probe.

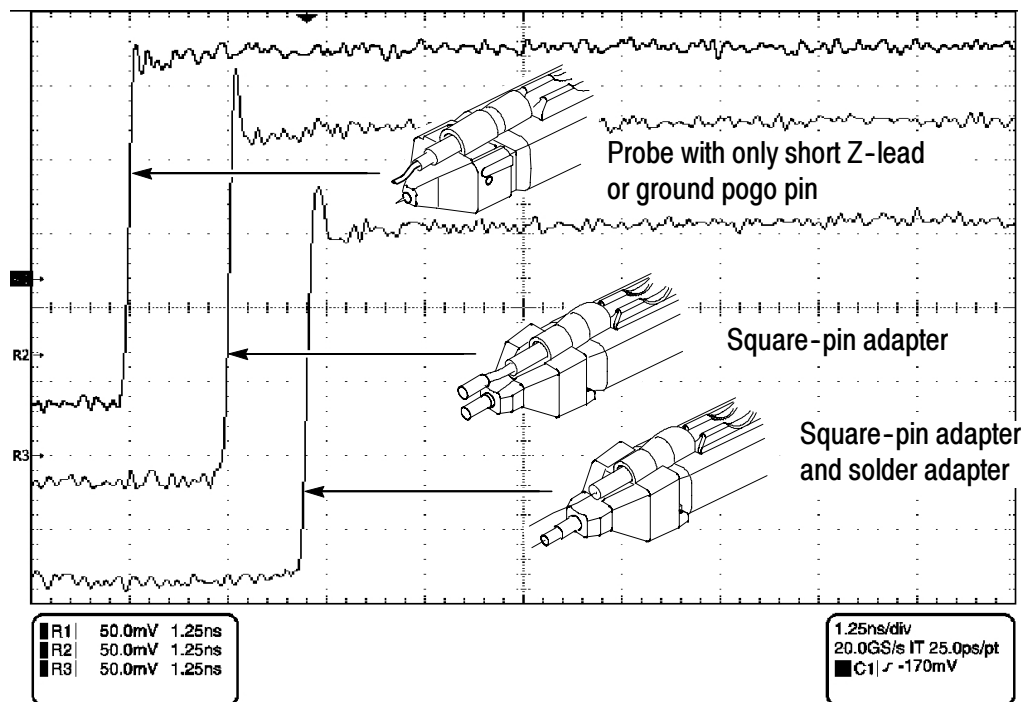

Figure 7: Typical effects of using the probe tip adapters



# Troubleshooting

When you connect the probe to a channel on the host instrument, two green LEDs, visible on the top of the P7260 compensation box, flash to show the results of diagnostic tests performed on the internal circuitry of the probe. The typical flash pattern response is described on page 4 of the *Product Description* section.

## Nontypical LED Flash Pattern When You Install the Probe

Table 3 describes LED flash pattern responses that indicate the probe did not pass the diagnostic tests.

Table 4 on page 32 describes the end states that follow nontypical flash patterns.

**Table 3: Nontypical LED flash patterns**

<b>5X or 25X LED</b>	<b>Description</b>	<b>Result</b>
<b>ONE flash</b>	Offset zero and offset gain adjustment factors are corrupted.	Measurements can be taken at the setting, but may not be accurate. The other setting is not affected.
<b>TWO flashes</b>	The amplifier and attenuator compensation factors are corrupted.	Measurements can be taken at this setting, but may not be accurate. The other setting is not affected.
<b>THREE flashes</b>	Both the offset zero and offset gain, and amplifier/attenuator factors are corrupted.	Measurements can be taken at this setting, but may not be accurate. The other setting is not affected.

Following nontypical flash patterns, the probe and host instrument will rest in one of the end states described in Table 4 on page 32. The column labeled “What to do” describes what to do after observing the end state.

**Table 4: End states following nontypical LED flash patterns**

End State	Description	What to do
Both LEDs are illuminated and remain lit.	Programming in the probe compensation box is corrupted.	Return the probe to your nearest Tektronix service center.
A message appears on screen of the host instrument. The LEDs are not illuminated.	EEPROM memory inside the probe compensation box is corrupted.	Follow the instructions in the message. If the problem persists, return the probe to your nearest Tektronix service center.
The 5X or the 25X LED flashes continuously while in use.	The offset zero and offset gain code is corrupted, or the amplifier and attenuator compensation factors are corrupted.	You can use this attenuation setting, but your measurements may not be accurate. You can use the other attenuation setting for probing. Contact your nearest Tektronix service center to arrange for service.

## Nontypical LED Response When You Press the SELECT Button

Refer to page 5 of the *Product Description* section for a description of the normal LED response to pressing the SELECT button.

Pressing the SELECT button causes the active LED to turn off. If the host instrument does not respond within about one second, and the same LED lights again, then the attenuation setting has not changed.

To troubleshoot this nontypical response, press the SELECT button again. If the response is the same, do the following:

- Disconnect and reconnect the probe, and then press the SELECT button. If the attenuation setting has not changed, investigate whether or not a host instrument program has been set up to disable manual attenuation changes.
- Try another channel or a different host instrument. If the response is the same, contact your nearest Tektronix service center.

# Specifications

These specifications apply to a P7260 6 GHz 5X/25X Active Probe when used with a Tektronix TekConnect host instrument.

The probe and host instrument must first be allowed to warm up for 20 minutes before measurements are taken.

## Warranted Characteristics

Warranted characteristics in Table 5 describe guaranteed performance within tolerance limits or certain type-tested requirements. Warranted characteristics marked with the  $\checkmark$  symbol are checked using procedures in the *P7260 5X/25X Active Probe Service Manual*.



**CAUTION.** To prevent damage to the probe or circuit under test, do not apply voltages beyond the nondestructive input voltage range of the probe.

**Table 5: Warranted electrical specifications**

Characteristic	Description
$\checkmark$ DC Gain (Probe only)	
5X	0.2 $\pm$ 2.0%
25X	0.04 $\pm$ 4.0%
$\checkmark$ Output Zero	$\pm$ 10 mV or less at output of probe, at 25 °C $\pm$ 5 °C $\pm$ 50 mV or less displayed on screen with TekConnect interface



**Table 5: Warranted electrical specifications (Cont.)**

Characteristic	Description
√ Small Signal Rise Time (Probe only)	
5X	≤75 ps for 20 °C to 30 °C for a 250 mV step
25X	≤85 ps for 20 °C to 30 °C for a 250 mV step

## Typical Characteristics

Typical characteristics in Table 6 and Table 7 describe typical but not guaranteed performance.

**Table 6: Typical electrical characteristics**

Characteristic	Description
Bandwidth (Probe only)	
5X	6.0 GHz (See Figure 9 on page 36)
25X	6.0 GHz (See Figure 10 on page 37)
Dynamic Range	
5X	±0.75 V (±350 mV at probe output)
25X	±3.0 V (±350 mV at probe output)
Linearity	
5X	±0.1% over dynamic range ±0.6 V ±0.5% over dynamic range to ±0.75 V
25X	±0.2% over dynamic range ±2.4 V ±0.5% over dynamic range ±3.0 V
Nondestructive Input Voltage Range	-30 V to +30 V (DC + peak AC)
Input Resistance	20 kΩ at DC (See Figure 8 on page 35)
Input Capacitance	<0.5 pF

**Table 6: Typical electrical characteristics (Cont.)**

Characteristic	Description
Offset Range	-5.0 V to +5.0 V
DC Offset Drift	150 $\mu\text{V}/^\circ\text{C}$ or less at output of probe 0.75 $\text{mV}/^\circ\text{C}$ or less displayed on screen with TekConnect interface
Offset Scale Accuracy (5X/25X)	$\pm 2\%$ of actual probe gain
DC Voltage Measurement Accuracy to Input (5X/25X)	$\pm(2\%$ of input + (2% of offset) + 50 mV + 20 mV)
Time Delay	5.415 ns $\pm$ 0.2 ns
Noise, System	$\leq 550 \mu\text{V}_{\text{RMS}}$ at probe output with tip grounded

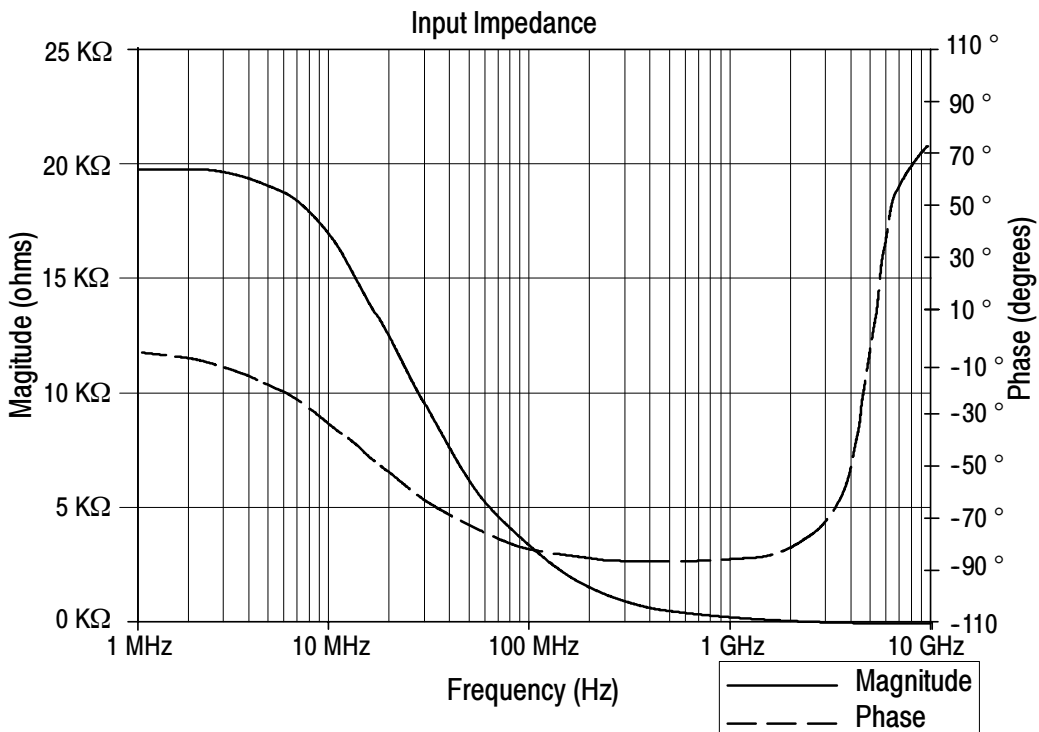

**Figure 8: Typical input impedance and phase versus frequency**

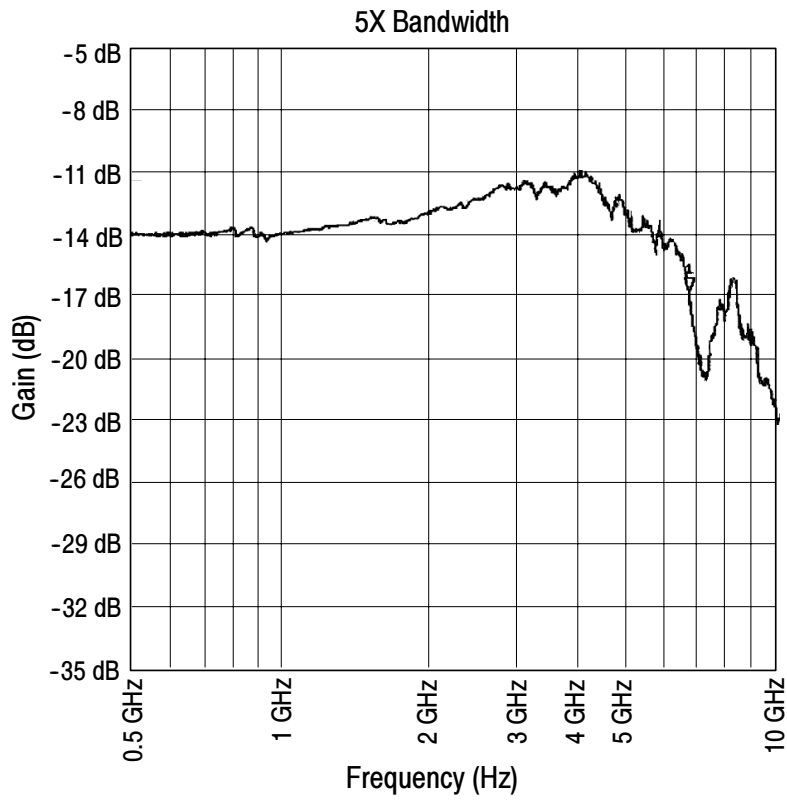

**Figure 9: Typical bandwidth at 5X attenuation**

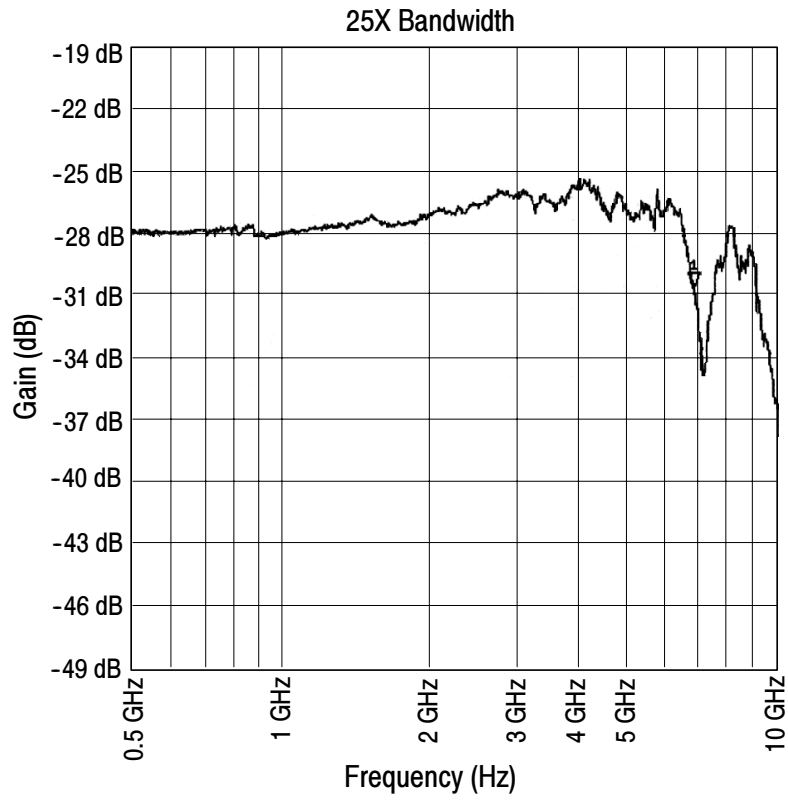

**Figure 10: Typical bandwidth at 25X attenuation**

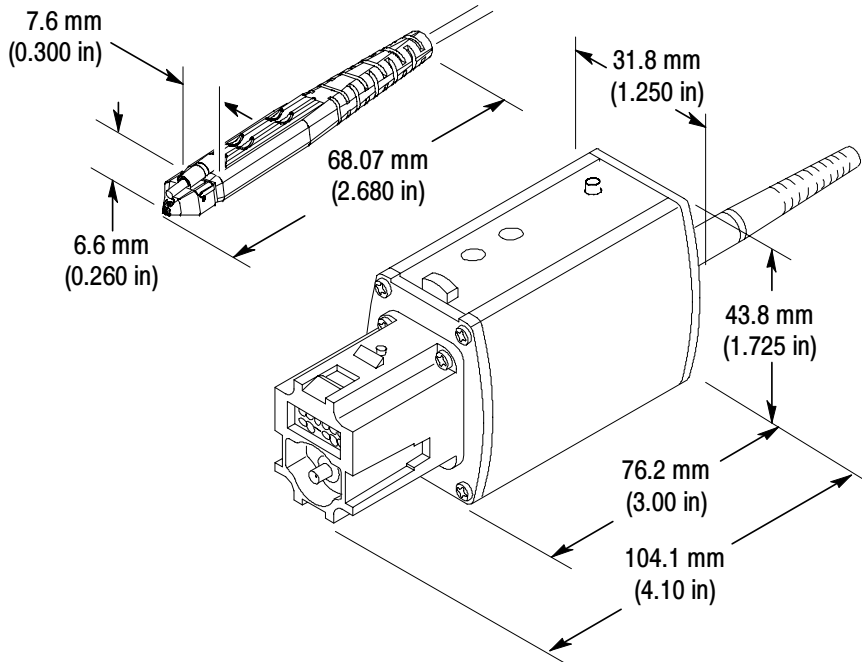

**Figure 11: Probe head and compensation box dimensions**

**Table 7: Typical mechanical characteristics**

Characteristic	Description
Unit Weight (probe only)	3.1 pounds (1406 g)
Cable Length	44.4 in (1.12 meters)

**Table 8: Environmental characteristics**

Characteristic	Standards or Description
Operating Temperature	+32 °F to +104 °F (0 °C to +40 °C)  The environmental exposure is the procedure stated in Tektronix Design Standard 062-2847-00 for Class 5 equipment.
Nonoperating Temperature	-67 °F to +165 °F (-55 °C to +75 °C)  The environmental exposure is the procedure stated in Tektronix Design Standard 062-2847-00 for Class 5 equipment.
Humidity	Operating: 90% RH up to +86 °F (+30 °C) 75% RH up to +104 °F (+40 °C)  Non-operating: 90% RH at 86 °F (+30 °C) 75% RH up to +167 °F (+75 °C)  The environmental exposure is as stated in Tektronix Design Standard 062-2847-00 for Class 5 equipment.

**Table 9: Certifications and compliances**

Category	Standards or description
EMC Compliance	Meets the intent of Directive 89/336/EEC for Electromagnetic Compatibility when it is used with the product(s) stated in the specifications table. Refer to the EMC specification published for the stated products. May not meet the intent of the directive if used with other products.
Pollution Degree Descriptions	<p>A measure of the contaminates that could occur in the environment around and within a product. Typically the internal environment inside a product is considered to be the same as the external. Products should be used only in the environment for which they are rated.</p> <p><b>Pollution Degree 1</b>                      No pollution or only dry, nonconductive pollution occurs. Products in this category are generally encapsulated, hermetically sealed, or located in clean rooms.</p> <p><b>Pollution Degree 2</b>                      Normally only dry, nonconductive pollution occurs. Occasionally a temporary conductivity that is caused by condensation must be expected. This location is a typical office/home environment. Temporary condensation occurs only when the product is out of service.</p> <p><b>Pollution Degree 3</b>                      Conductive pollution, or dry, nonconductive pollution that becomes conductive due to condensation. These are sheltered locations where neither temperature nor humidity is controlled. The area is protected from direct sunshine, rain, or direct wind.</p> <p><b>Pollution Degree 4</b>                      Pollution that generates persistent conductivity through conductive dust, rain, or snow. Typical outdoor locations.</p>
Equipment Type	Test and measuring
Pollution Degree	Pollution Degree 2 (as defined in IEC 61010-1. Note: Rated for indoor use only.

# Replaceable Parts

This section contains a list of replaceable parts for the P7260. Use this list to identify and order replacement parts.

## Parts Ordering Information

Replacement parts are available from or through your local Tektronix, Inc. service center or representative.

Changes to Tektronix instruments are sometimes made to accommodate improved components as they become available and to give you the benefit of the latest circuit improvements. Therefore, when ordering parts, it is important to include the following information in your order:

- Part number
- Instrument type or model number
- Instrument serial number
- Instrument modification number, if applicable

If a part you order has been replaced with a different or improved part, your local Tektronix service center or representative will contact you concerning any change in the part number.



## Using the Replaceable Parts List

The tabular information in the Replaceable Parts List is arranged for quick retrieval. Understanding the structure and features of the list will help you find the information you need for ordering replacement parts.

### Item Names

In the Replaceable Parts List, an Item Name is separated from the description by a colon (:). Because of space limitations, an Item Name may sometimes appear as incomplete. For further Item Name identification, U.S. Federal Cataloging Handbook H6-1 can be used where possible.

### Indentation System

This parts list is indented to show the relationship between items. The following example is of the indentation system used in the Description column:

<i>1</i>	<i>2</i>	<i>3</i>	<i>4</i>	<i>5</i>	<i>Name &amp; Description</i>
					<i>Assembly and/or Component</i>
					<i>Attaching parts for Assembly and/or Component</i>
					<i>(END ATTACHING PARTS)</i>
					<i>Detail Part of Assembly and/or Component</i>
					<i>Attaching parts for Detail Part</i>
					<i>(END ATTACHING PARTS)</i>
					<i>Parts of Detail Part</i>
					<i>Attaching parts for Parts of Detail Part</i>
					<i>(END ATTACHING PARTS)</i>

Attaching parts always appear at the same indentation as the item it mounts, while the detail parts are indented to the right. Indented items are part of, and included with, the next higher indentation. Attaching parts must be purchased separately, unless otherwise specified.

### Abbreviations

Abbreviations conform to American National Standards Institute (ANSI) standard Y1.1

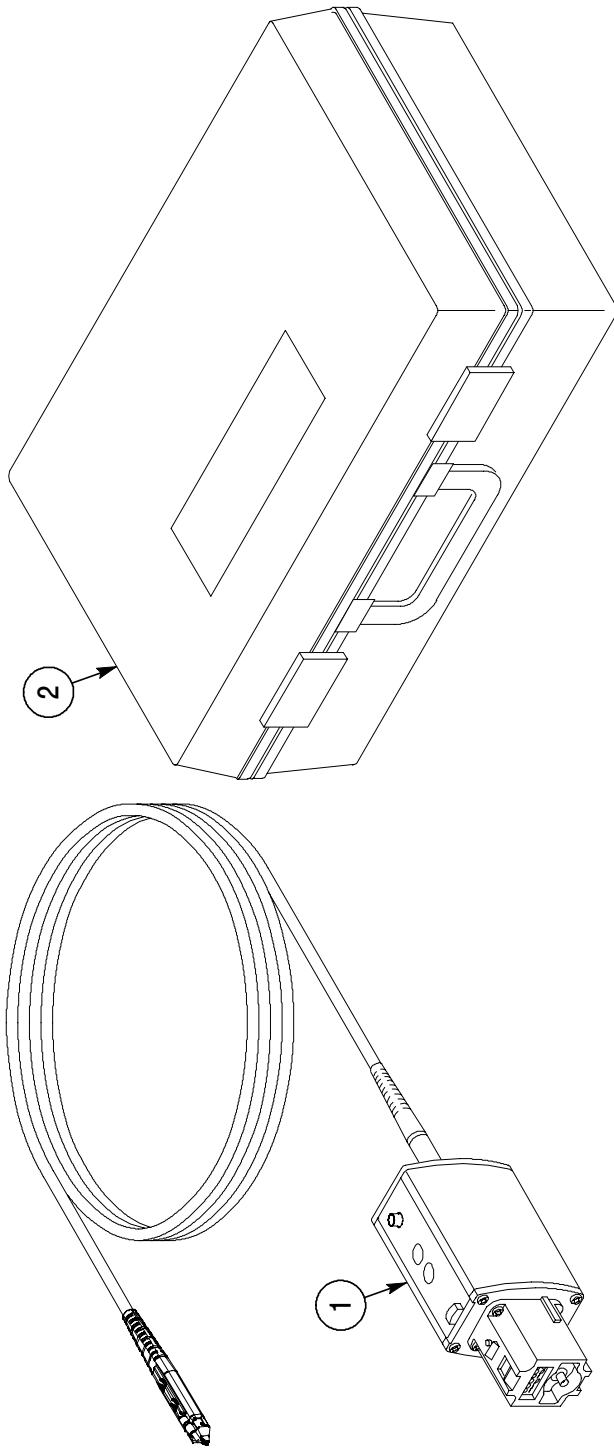
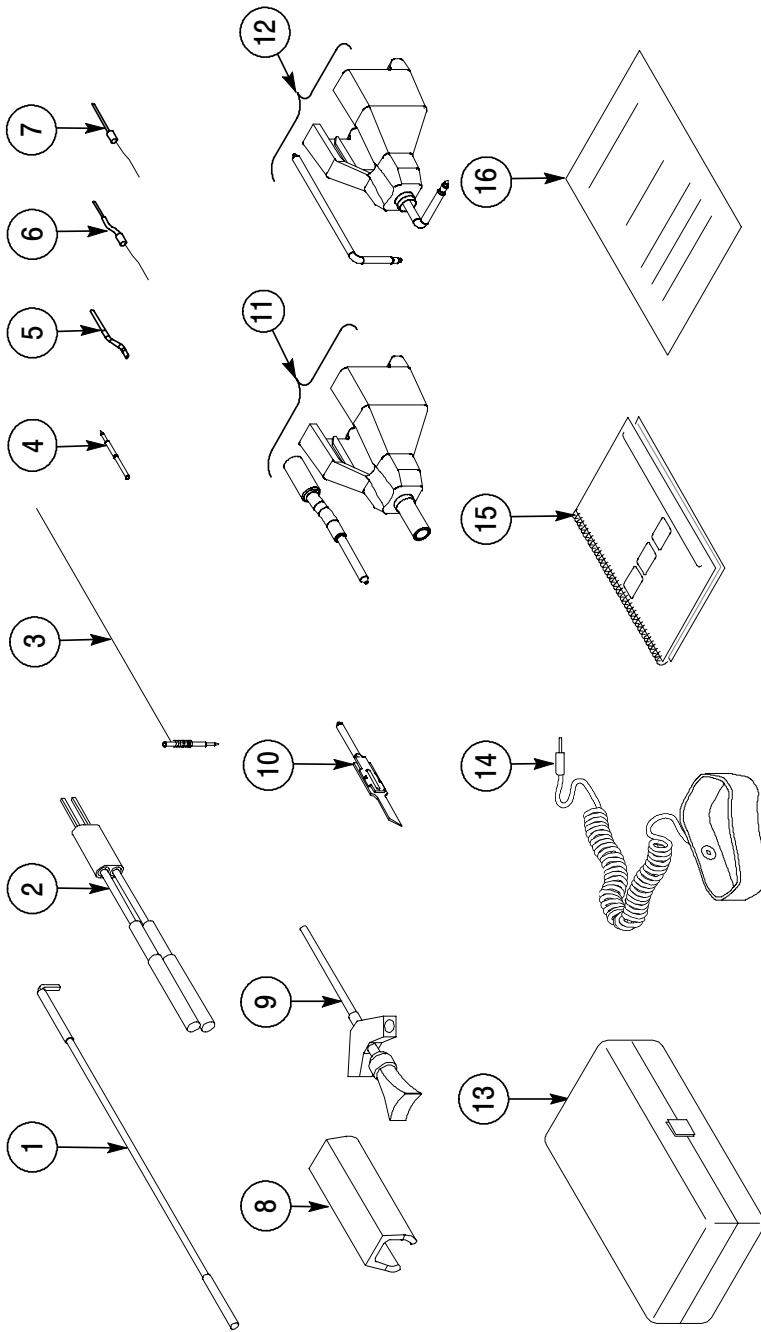

Figure 12: P7260 replaceable parts

Fig. & index no.	Tektronix part no.	Serial no. Effective	Dscont	Qty	12345 name & description	Mfr. code	Mfr. part no.
12-1	010-0657-XX			1	PROBE ASSEMBLY; P7260 SERVICE REPLACEMENT, SERIALIZED, TESTED, WITHOUT ACCESSORIES AND MANUAL	80009	010-0657-XX
-2	016-1879-XX			1	CASE; STORAGE: PLASTIC, W/FOAM	80009	016-1879-XX



**Figure 13: P7260 standard accessories**

Fig. & index no.	Tektronix part no.	Serial no. Effective	Dscont	Qty	12345 name & description	Mfr. code	Mfr. part no.
<b>STANDARD ACCESSORIES</b>							
13-1	196-3437-10			1	LEAD, GROUND; DISCRETE;SDI, 23AWG, 3.0 L, 0.325, SET OF 2	80009	196-3437-10
-2	196-3434-XX			1	LEAD, ELEC; DISCRETE, CPD, 2, 23 AWG, RED & BLACK, 2.300 L, 1 X 2, 0.1 CTR, 0.025 SQ PIN X 2, JACK TIP	80009	196-3434-XX
-3	196-3482-XX			1	CUSTOMIZABLE GROUND LEAD, SET OF 5	80009	196-3482-XX
-4	016-1917-XX			1	ACCESSORY KIT; POGO PIN, SET OF 8	80009	016-1917-XX
-5	196-3491-XX			1	ACCESSORY KIT; Z LEAD, SET OF 10	80009	196-3491-XX
-6	196-3495-XX			1	ACCESSORY KIT; SOLDERABLE GND LEAD, SET OF 8	80009	196-3495-XX
-7	196-3493-XX			1	ACCESSORY KIT; SOLDERABLE RES LEAD, SET OF 8	80009	196-3493-XX
-8	016-1886-XX			1	MARKER BAND SET; TWO EACH OF 5 COLORS	80009	016-1886-XX
-9	206-0364-XX				TIP, PROBE; MICROCKT TEST, 0.05 CTR	80009	206-0364-XX
-10	-----			1	ADAPTER, SURE TOE; PROBING INTERFACE FOR SMALL PITCH IC'S, SET OF 4 (REORDER ST501, PKG OF 12)	80009	-----
-11	016-1910-XX			1	ACCESSORY KIT; SQUARE PIN ADAPTER, SET OF 4	80009	016-1910-XX
-12	016-1913-XX			1	ACCESSORY KIT; L-ADAPTERS, SET OF 2	80009	016-1913-XX
-13	006-7164-XX			1	BOX,PLASTIC:4.625 X 2.875 X 1.0	80009	006-7164-XX
-14	006-3415-XX			1	STRAP,WRIST:3M TYPE 2214, ADJ,6 FT COILED CORD	TK0623	RTI 8454001829
-15	071-0922-XX			1	MANUAL,TECH:USER,P7260	80009	071-0922-XX
-16	001-1349-XX			1	REORDER SHEET; ACTIVE PROBE ACCESSORY	80009	001-1349-XX

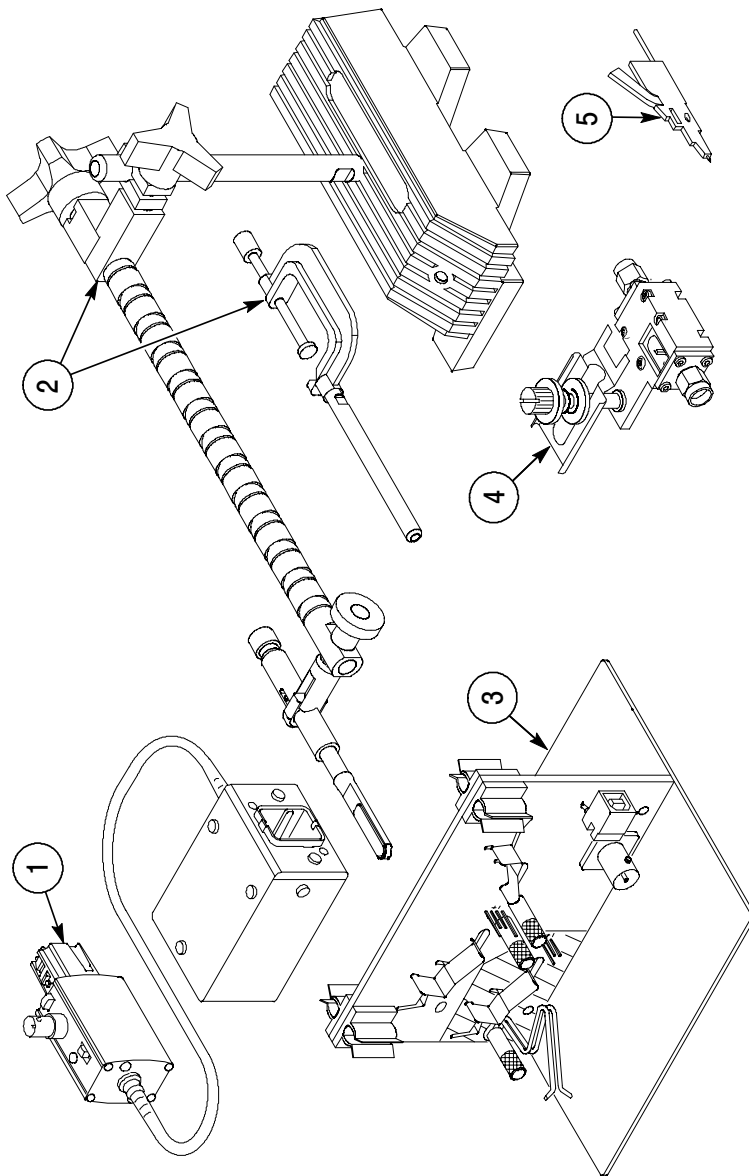

**Figure 14: P7260 optional accessories**

Fig. & index no.	Tektronix part no.	Serial no. Effective	Dscont	Qty	12345 name & description	Mfr. code	Mfr. part no.
<b>OPTIONAL ACCESSORIES</b>							
14-1	067-0422-XX			1	CALIBRATION FIXTURE ASSY:ECB TO TOP,P7000 SERIES	80009	067-0422-XX
-2	PPM100			1	POSITIONER; PROBE POSITIONER; CLAMP, BASE, POSITIONING ARM, PROBE HOLDER	80009	PPM100
-3	067-0484-XX			1	FIXTURE, CAL; PROBE CAL DESKEW	80009	067-0484-XX
-4	067-1456-XX			1	FIXTURE; PROBE CAL	80009	067-1456-XX
-5	SMK4			1	IC GRABBER; MICRO CLIP, 0.025 DIA LEAD, 2 SETS OF 2	80009	SMK4

**CROSS INDEX - MFR. CODE NUMBER TO MANUFACTURER**

<b>Mfr. Code</b>	<b>Manufacturer</b>	<b>Address</b>	<b>City, State, Zip Code</b>
80009	TEKTRONIX INC	14150 SW KARL BRAUN DR PO BOX 500	BEAVERTON OR 97077-0001
TK0623	GENERAL TOOL & SUPPLY CO	2705 NW NICOLAI ST	PORTLAND, OR 97210