



ABN 43 064 478 842

231 Osborne Avenue Clayton South, VIC 3169
PO Box 1548, Clayton South, VIC 3169
t 03 9265 7400 f 03 9558 0875
freecall 1800 680 680
www.tmgtestequipment.com.au

Test & Measurement

- > sales
- > rentals
- > calibration
- > repair
- > disposal

Complimentary Reference Material

This PDF has been made available as a complimentary service for you to assist in evaluating this model for your testing requirements.

TMG offers a wide range of test equipment solutions, from renting short to long term, buying refurbished and purchasing new. Financing options, such as Financial Rental, and Leasing are also available on application.

TMG will assist if you are unsure whether this model will suit your requirements.

Call TMG if you need to organise repair and/or calibrate your unit.

If you click on the "Click-to-Call" logo below, you can call us for FREE!

TMG Corporate Website

TMG Products Website



Click-to-Call
TMG Now



Product Lifecycle Management System

Disclaimer:

All trademarks appearing within this PDF are trademarks of their respective owners.



User Manual



P7330

3.5 GHz Differential Probe

071-0758-04

Warning

The servicing instructions are for use by qualified personnel only. To avoid personal injury, do not perform any servicing unless you are qualified to do so. Refer to all safety summaries prior to performing service.

www.tektronix.com

Copyright © Tektronix, Inc. All rights reserved.

Tektronix products are covered by U.S. and foreign patents, issued and pending. Information in this publication supercedes that in all previously published material. Specifications and price change privileges reserved.

Tektronix, Inc., P.O. Box 500, Beaverton, OR 97077

TEKTRONIX, TEK, SureFoot, and TekConnect are registered trademarks of Tektronix, Inc., and KlipChip is a trademark of Tektronix, Inc.

WARRANTY

Tektronix warrants that the products that it manufactures and sells will be free from defects in materials and workmanship for a period of one (1) year from the date of shipment. If a product proves defective during this warranty period, Tektronix, at its option, either will repair the defective product without charge for parts and labor, or will provide a replacement in exchange for the defective product.

In order to obtain service under this warranty, Customer must notify Tektronix of the defect before the expiration of the warranty period and make suitable arrangements for the performance of service. Customer shall be responsible for packaging and shipping the defective product to the service center designated by Tektronix, with shipping charges prepaid. Tektronix shall pay for the return of the product to Customer if the shipment is to a location within the country in which the Tektronix service center is located. Customer shall be responsible for paying all shipping charges, duties, taxes, and any other charges for products returned to any other locations.

This warranty shall not apply to any defect, failure or damage caused by improper use or improper or inadequate maintenance and care. Tektronix shall not be obligated to furnish service under this warranty a) to repair damage resulting from attempts by personnel other than Tektronix representatives to install, repair or service the product; b) to repair damage resulting from improper use or connection to incompatible equipment; c) to repair any damage or malfunction caused by the use of non-Tektronix supplies; or d) to service a product that has been modified or integrated with other products when the effect of such modification or integration increases the time or difficulty of servicing the product.

THIS WARRANTY IS GIVEN BY TEKTRONIX IN LIEU OF ANY OTHER WARRANTIES, EXPRESS OR IMPLIED. TEKTRONIX AND ITS VENDORS DISCLAIM ANY IMPLIED WARRANTIES OF MERCHANTABILITY OR FITNESS FOR A PARTICULAR PURPOSE. TEKTRONIX' RESPONSIBILITY TO REPAIR OR REPLACE DEFECTIVE PRODUCTS IS THE SOLE AND EXCLUSIVE REMEDY PROVIDED TO THE CUSTOMER FOR BREACH OF THIS WARRANTY. TEKTRONIX AND ITS VENDORS WILL NOT BE LIABLE FOR ANY INDIRECT, SPECIAL, INCIDENTAL, OR CONSEQUENTIAL DAMAGES IRRESPECTIVE OF WHETHER TEKTRONIX OR THE VENDOR HAS ADVANCE NOTICE OF THE POSSIBILITY OF SUCH DAMAGES.



Preface

This is the User Manual for the P7330 differential probe. This manual provides operating information, specifications, and a replaceable parts list.

Related Manuals

If you need to do a performance verification or make internal adjustments to your probe, refer to the *P7330 3.5 GHz Differential Probe Service Manual*, Tektronix part number 071-1057-XX. The manual is a printable pdf file, and is available on both the Tektronix website and the Optional Applications CD that is included with Tektronix oscilloscopes featuring the TekConnect interface.

Contacting Tektronix

Phone	1-800-833-9200*
Address	Tektronix, Inc. Department or name (if known) 14200 SW Karl Braun Drive P.O. Box 500 Beaverton, OR 97077 USA
Web site	www.tektronix.com
Sales support	1-800-833-9200, select option 1*
Service support	1-800-833-9200, select option 2*
Technical support	Email: techsupport@tektronix.com 1-800-833-9200, select option 3* 6:00 a.m. - 5:00 p.m. Pacific time

* **This phone number is toll free in North America. After office hours, please leave a voice mail message. Outside North America, contact a Tektronix sales office or distributor; see the Tektronix web site for a list of offices.**

Table of Contents

General Safety Summary	iii
Preface	v
Related Manuals	v
Contacting Tektronix	vi
Getting Started	1
TekConnect Interface	1
Functional Check	3
Options	4
Features and Standard Accessories	5
Optional Accessories	9
Operating Basics	11
Input Voltage Limits	12
Maximum Input Voltage	12
Common-Mode Signal Range	12
Differential-Mode Signal Range	12
Common-Mode Rejection	12
Probing Techniques to Maximize CMRR	13
Input Impedance and Probe Loading	14
Probe Grounding	15
Electrical Effects of Accessories	16
Reference	17
Problems with Single-Ended Measurements	17
Differential Measurements	17
Common-Mode Rejection Ratio	18
Assessing CMRR Error	18
Input Impedance Effects on CMRR	19
Extending the Input Leads	19
Extending the Ground Lead	20
Appendix A: Specifications	21
Appendix B: User Service	27
Appendix C: Replaceable Parts	29

List of Figures

Figure 1: P7330 differential probe featuring the TekConnect Interface	1
Figure 2: Connecting and disconnecting the probe	2
Figure 3: Probe functional check connections	3
Figure 4: Protect the probe tips with the protective cover	11
Figure 5: Using the variable spacing adapter	13
Figure 6: Using the TwinFoot adapter	13
Figure 7: Typical probe input model	14
Figure 8: Probe ground input	15
Figure 9: Typical effects on a signal using probe tip adapters ..	16
Figure 10: Simplified model of a differential amplifier	18
Figure 11: Twisting the input leads	20
Figure 12: Typical common-mode gain	24
Figure 13: Typical differential input impedance vs frequency ..	24
Figure 14: Probe head and compensation box dimensions	25
Figure 15: P7330 replaceable parts	31
Figure 16: P7330 standard accessories	33
Figure 17: P7330 optional accessories	35



General Safety Summary

Review the following safety precautions to avoid injury and prevent damage to this product or any products connected to it. To avoid potential hazards, use this product only as specified.

To Avoid Fire or Personal Injury

Connect and Disconnect Properly. Connect the probe output to the measurement instrument before connecting the probe to the circuit under test. Disconnect the probe input and the probe ground from the circuit under test before disconnecting the probe from the measurement instrument.

Observe All Terminal Ratings. To avoid fire or shock hazard, observe all ratings and markings on the product. Consult the product manual for further ratings information before making connections to the product.

The common terminal is at ground potential. Do not connect the common terminal to elevated voltages.

Do Not Operate Without Covers. Do not operate this product with covers or panels removed.

Do Not Operate With Suspected Failures. If you suspect there is damage to this product, have it inspected by qualified service personnel.

Do Not Operate in Wet/Damp Conditions.

Do Not Operate in an Explosive Atmosphere.

Keep Product Surfaces Clean and Dry.

Safety Terms and Symbols

Terms in This Manual. These terms may appear in this manual:



WARNING. *Warning statements identify conditions or practices that could result in injury or loss of life.*



CAUTION. *Caution statements identify conditions or practices that could result in damage to this product or other property.*

Terms on the Product. These terms may appear on the product:

DANGER indicates an injury hazard immediately accessible as you read the marking.

WARNING indicates an injury hazard not immediately accessible as you read the marking.

CAUTION indicates a hazard to property including the product.

Symbols on the Product. These symbols may appear on the product:



CAUTION
Refer to Manual

Getting Started

The P7330 is a high-bandwidth (3.5 GHz) active differential probe with a miniaturized probe head design. The probe has low circuit loading, high common-mode rejection, and comes with a variety of accessories for connecting to surface-mount devices and other components.

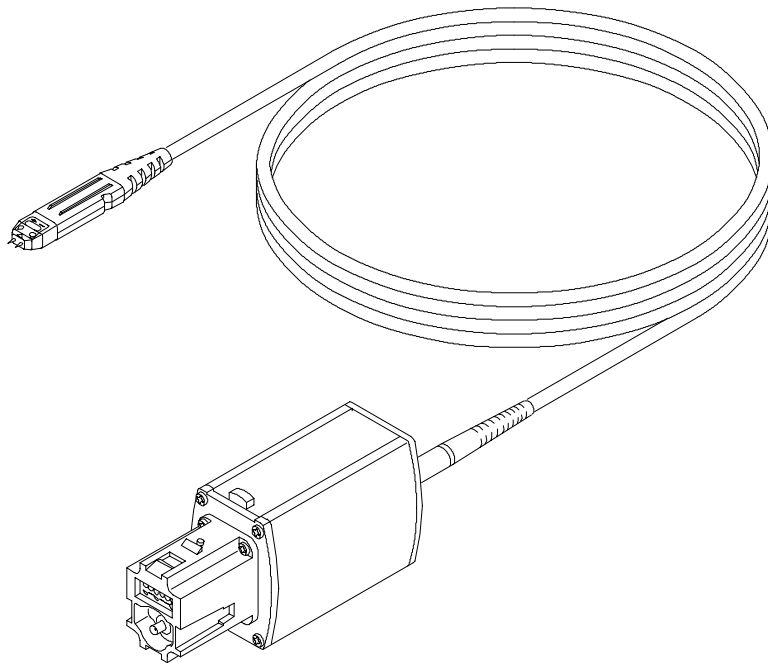

Figure 1: P7330 differential probe featuring the TekConnect Interface

TekConnect Interface

The P7330 probe is powered through a TekConnect Interface between the probe compensation box and the oscilloscope. The TekConnect Interface provides a communication path through contact pins on the host instrument. Power, signal, offset, and probe characteristic data transfer through the interface.

When the probe is connected, the oscilloscope reads EEPROM information from the probe, identifying the device and allowing the appropriate power supplies to be turned on. The preamp inputs on the oscilloscope are ESD protected by remaining grounded until a valid TekConnect device is detected.

The TekConnect Interface features a spring-loaded latch that provides audible and tactile confirmation that a reliable connection has been made to the oscilloscope. Slide the probe into the TekConnect receptacle on the oscilloscope. The probe snaps into the oscilloscope when fully engaged. See Figure 2.

To release the probe from the oscilloscope, grasp the compensation box, press the latch button, and pull out the probe.

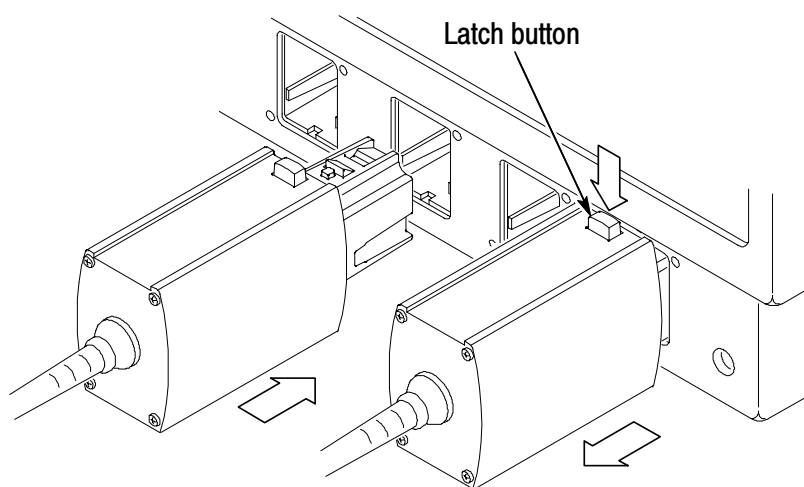

Figure 2: Connecting and disconnecting the probe

Functional Check

After installing the probe on the oscilloscope, a functional check may be performed using the PROBE COMPENSATION connections on the front panel of the oscilloscope. See Figure 3.

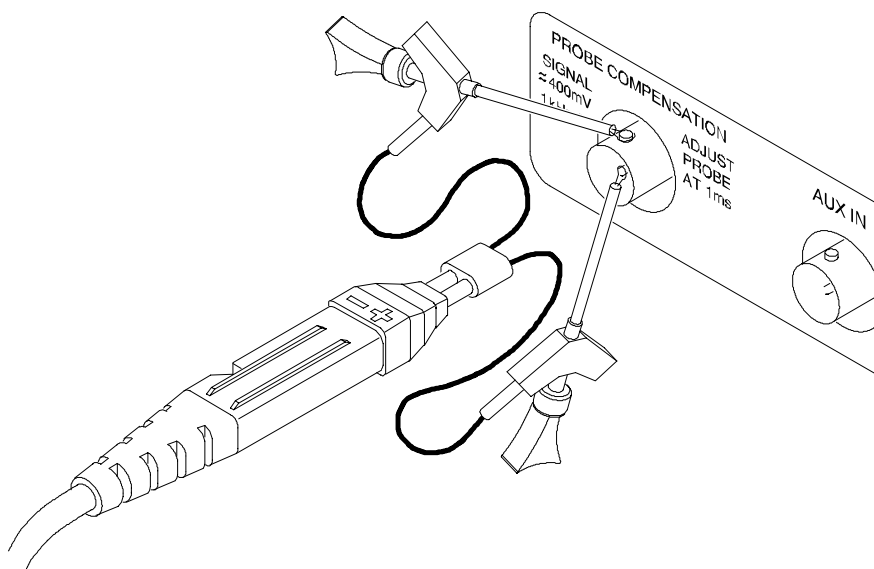

Figure 3: Probe functional check connections

1. Connect the probe to the oscilloscope.
2. Set the oscilloscope to display the probe channel.
3. Connect the square pin adapter to the probe tip, and connect the Y-lead adapter to the square pin adapter. Plug the SMT KlipChips into the Y-lead adapter.
4. Connect the SMT KlipChips to the PROBE COMPENSATION connections on the oscilloscope.
5. Adjust the oscilloscope to display a stable calibration waveform.

NOTE. *If your instrument supports probe calibration routines, now is a good time to perform them.*

6. Disconnect the probe from the PROBE COMPENSATION connector and connect the two KlipChips together.
7. With the probe offset set to 0.0 V, the oscilloscope display should be at the ground reference.
8. Set the oscilloscope volts/division to 500 mV.
9. Adjust the probe offset. The displayed waveform should vary between approximately +1.0 V and -1.0 V.

Options

The following options are available when ordering the P7330 probe:

- Option D1 - Calibration Data
- Option C3 - 3 years Calibration Service
- Option D3 - 3 years Calibration Data (requires Option C3)
- Option R3 - 3 years Extended Warranty

Features and Standard Accessories

Table 1 shows the features and standard accessories of the P7330 differential probe.

Table 1: P7330 features and standard accessories

Feature/Accessory	Description
	<p>TekConnect Interface. The TekConnect Interface provides a communication path between the probe and the oscilloscope. Contact pins provide power, signal, offset, and probe characteristic data transfer.</p> <p>The probe snaps into the oscilloscope when fully engaged. To remove, grasp the compensation box, press the latch button, and pull the probe out.</p>
	<p>Input connections. The plus and minus connections on the probe tip accept the standard and optional probe accessories. (Some of the accessories connect to the probe tip through the square pin adapter). The ground lead connects to the probe head through a slot in the side of the insulated probe housing.</p> <p>WARNING: Skin penetration hazard. To prevent injury, install the probe tip cover when the probe is not in use. The probe tips are extremely sharp to ensure good contact and measurement integrity.</p>
	<p>Probe tip cover. The probe tip cover is shipped on the probe. The probe tips are extremely sharp to ensure good contact and measurement integrity. When not using the probe, slide the probe tip cover over the probe head to prevent damage to the probe tips and to protect yourself from personal injury.</p> <p>Tektronix part number: 200-4236-00</p>
	<p>Three-inch ground lead (2 ea). Use the ground lead for connecting the probe ground to the circuit, if needed. The socketed end of the lead may be connected to accessories, or fitted onto 0.025-inch square pins.</p> <p>Tektronix part number: 196-3469-00 (package of 2)</p>

Table 1: P7330 features and standard accessories (Cont.)

Feature/Accessory	Description
	<p>Variable spacing adapter (4 ea). The variable spacing adapter fits over the probe tip. Push the adapter onto the probe tip until it seats against the probe head.</p> <p>Use the variable spacing adapter to probe any two adjacent leads or test points spaced between 0.020 and 0.180-inches apart. Adjust the articulated pins by gently rotating them using a pair of tweezers.</p> <p>NOTE: The articulated pins can be bent, but they are fragile. Use extreme care when bending the pins.</p> <p>The elastomeric contacts inside the adapter are rated for 50 - 75 insertion cycles with the probe tip. Replace the adapter after exceeding these limits to avoid unreliable operation.</p> <p>Tektronix part number: 016-1885-00 (package of 4)</p>
	<p>Square pin adapter (4 ea). Push the square pin adapter onto the probe tip until it seats against the probe head. Use the square pin adapter to connect the probe to other accessories, such as the Y-lead adapter or TwinFoot adapter. The inputs on the adapter are spaced 0.100-inches apart.</p> <p>CAUTION: To avoid damaging the square pin connectors, do not insert anything larger than a 0.025-inch square pin into the inputs.</p> <p>The elastomeric contacts inside the adapter are rated for 50 - 75 insertion cycles with the probe tip. Replace the adapter after exceeding these limits to avoid unreliable operation.</p> <p>Tektronix part number: 016-1884-00 (package of 4)</p>

Table 1: P7330 features and standard accessories (Cont.)

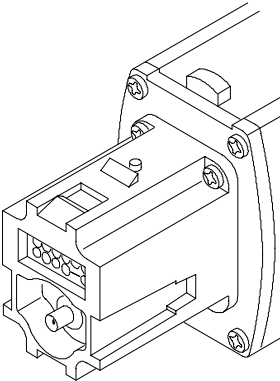
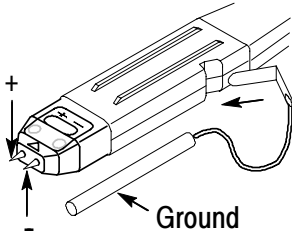
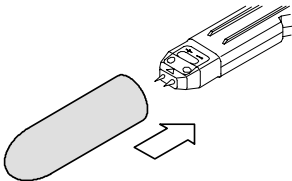
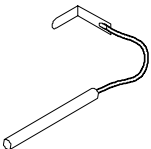

Feature/Accessory	Description
	<p>TwinFoot adapter (4 ea). Use the TwinFoot adapter to probe two adjacent leads on a surface-mount integrated circuit. The TwinFoot adapter connects to the probe through the square pin adapter. Flexible fingers adapt to a range of lead spacings. See Figure 6 on page 13.</p> <p>Tektronix part number: 016-1785-00 (package of 4)</p>
	<p>Y-lead adapter (2 ea). The Y-lead adapter connects to the probe through the square pin adapter. The socketed ends of the leads may be connected to the probe tips and accessories, or fitted onto 0.025-inch square pins.</p> <p>Tektronix part number: 196-3468-00 (package of 2)</p>
	<p>X-lead adapter (2 ea). The X-lead adapter connects between accessories fitted with 0.025-inch pins, such as the SMT KlipChip and Micro KlipChip adapters.</p> <p>You can use the X-lead adapter with the adapters below to make connections between the probe tip and your circuit under test. Be aware of the electrical effects of the added lead length of the adapters, especially as circuit frequencies increase.</p> <p>Tektronix part number: 196-3473-XX (package of 1)</p>
	<p>SMT KlipChip adapter (2 ea). Use this accessory to probe the leads on dual-in-line packages (DIP).</p> <p>Tektronix part number: 206-0364-XX (package of 1)</p>
<p>Cable marker bands</p> 	<p>Cable marker bands (10 ea). Attach matching pairs of the marker bands onto the cable at the head and compensation box of each probe. The marker bands enable quick verification of which probe is connected to which instrument channel.</p> <p>Tektronix part number: 016-1315-00 (package of 10)</p>

Table 1: P7330 features and standard accessories (Cont.)

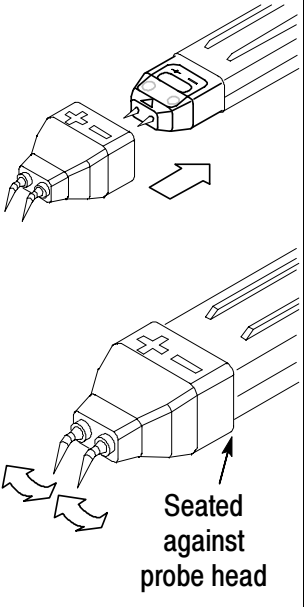
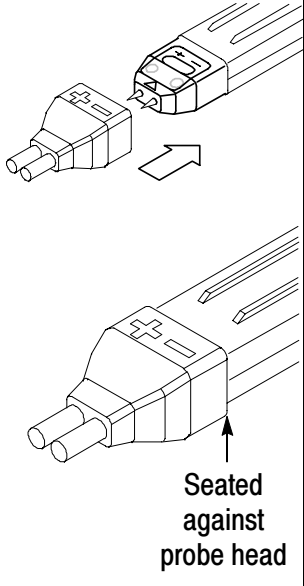
Feature/Accessory	Description
	<p>Plastic accessory box. Use the plastic box to store the probe accessories when not in use.</p> <p>Tektronix part number: 006-7164-00</p>
	<p>Instrument case. The instrument case protects the probe from harsh environments and provides room for storing optional accessories.</p> <p>Tektronix part number: 016-1879-XX</p>
	<p>Calibration certificate. A certificate of traceable calibration is provided with every instrument shipped.</p>
	<p>Accessory reorder sheet. Use the accessory reorder sheet as a quick guide for ordering accessories for your probe. The sheet provides photos and part numbers for identifying your accessories.</p> <p>Tektronix part number 001-1362-XX</p>
	<p>User Manual. Provides instructions for operating and maintaining the P7330 differential probe</p> <p>Tektronix part number: 071-0758-XX</p>
	<p>Antistatic wrist strap. When using the probe, always work at an antistatic work station and wear the anti static wrist strap.</p> <p>Tektronix part number: 006-3415-04</p>

Optional Accessories

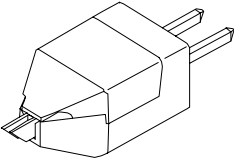
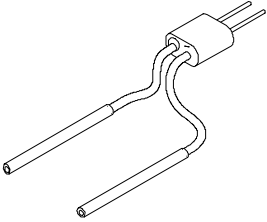
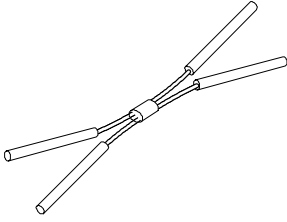
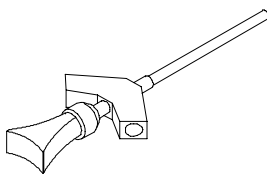
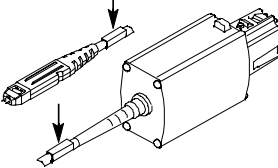
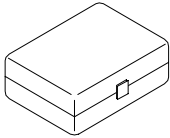
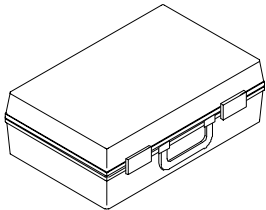
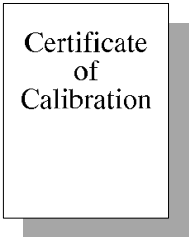
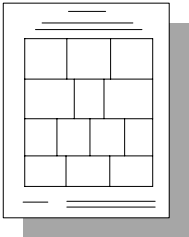
Table 2 shows the optional accessories that you can order for the P7330 differential probe.

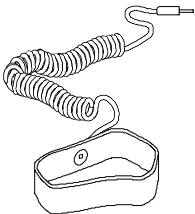
Table 2: Optional accessories

Accessory	Description
	<p>TekConnect Interface calibration adapter. The calibration adapter is required when a performance verification or adjustment is done on the probe. It provides connectors and test points for internal probe measurements.</p> <p>Tektronix part number 067-0422-00</p>
	<p>Probe calibration fixture. Use the probe calibration fixture to perform some of the calibration procedures. The calibration fixture connects to signal sources used to test the probe characteristics.</p> <p>Tektronix part number 067-0419-XX</p>
	<p>IEEE1394 Adapter. The IEEE1394 Adapter allows you to probe signals on the bus, external to system enclosures, without disturbing system operation. The adapter maintains a balanced 55 Ω signal path and can be used in both single-ended and differential modes.</p> <p>Tektronix part number: 679-5027-00</p>

Table 2: Optional accessories (Cont.)

Accessory	Description
	<p>Micro KlipChip adapters. Use the adapters to probe the leads on integrated circuits that are surface-mounted.</p> <p>Tektronix part number: SMK4 (package of 4)</p>
	<p>Calibration software and instructions.</p> <p>Use the Optional Applications Software CD that is shipped with host instruments featuring the TekConnect interface. Alternatively, you can download the software from the Tektronix website, or order the CD using the part number below.</p> <p>Tektronix part number: 063-3376-XX</p>

Operating Basics

This section discusses operating considerations and probing techniques. For more detailed information about differential measurements and common-mode rejection ratio (CMRR), see the *Reference* section on page 17.

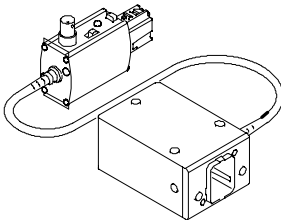
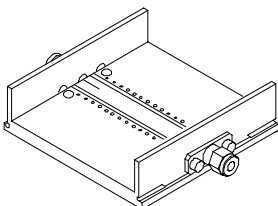
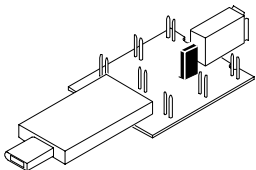
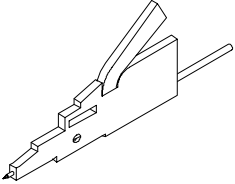
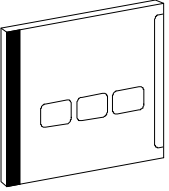
The P7330 probe design is optimized for high bandwidth, low capacitance applications; it is not a general purpose probe. The probe head and tips are miniaturized for electrical characteristics and access to dense circuitry, and must be handled carefully. Rough or careless use will likely damage the probe.

To avoid damaging the probe tips, minimize your lateral pressure on the tips. Always probe as straight onto the circuit (perpendicular) as possible. The probe tips are extremely sharp to ensure good contact and measurement integrity.



WARNING. *The sharp probe tips pose a skin penetration hazard. Use care when handling the probe. To prevent injury and/or probe damage, install the protective cover over the probe tips when the probe is not in use (see Figure 4).*

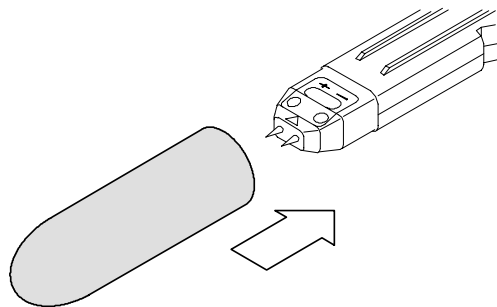

Figure 4: Protect the probe tips with the protective cover

Input Voltage Limits

The P7330 differential probe is designed to probe low-voltage circuits. Before probing a voltage, take into account the limits for maximum input voltage, the common-mode signal range, and the differential-mode signal range. For specific limits, see *Specifications* on page 21.

Maximum Input Voltage

The maximum input voltage is the maximum voltage to ground that the inputs can withstand without damaging the probe input circuitry.



CAUTION. To avoid damaging the inputs of the P7330 differential probe, do not apply more than ± 15 V (DC + peak AC) between each input and ground.

Common-Mode Signal Range

The common-mode signal range is the maximum voltage that you can apply to each input, with respect to earth ground, without saturating the input circuitry of the probe. A common-mode voltage that exceeds the common-mode signal range may produce an erroneous output waveform even when the differential-mode specification is met. For *Specifications*, refer to page 21.

Differential-Mode Signal Range

The differential-mode signal range is the maximum voltage difference between the plus and minus inputs that the probe can accept without distorting the signal. The distortion from a voltage that is too large can result in a clipped or otherwise distorted and inaccurate measurement. For *Specifications*, refer to page 21.

Common-Mode Rejection

The common-mode rejection ratio (CMRR) is the ability of a probe to reject signals that are common to both inputs. More precisely, CMRR is the ratio of the differential gain to the common-mode gain. The higher the ratio, the greater the ability to reject common-mode signals. For additional information about CMRR, see page 18.

Probing Techniques to Maximize CMRR

The common-mode rejection of the probe is highest when the probe is applied directly to the circuit, without using adapters. However, some probing tasks are made easier using accessories included with the probe. The accessories shown in Figures 5 and 6 achieve a high CMRR by minimizing the distance between the probe head and the signal source.

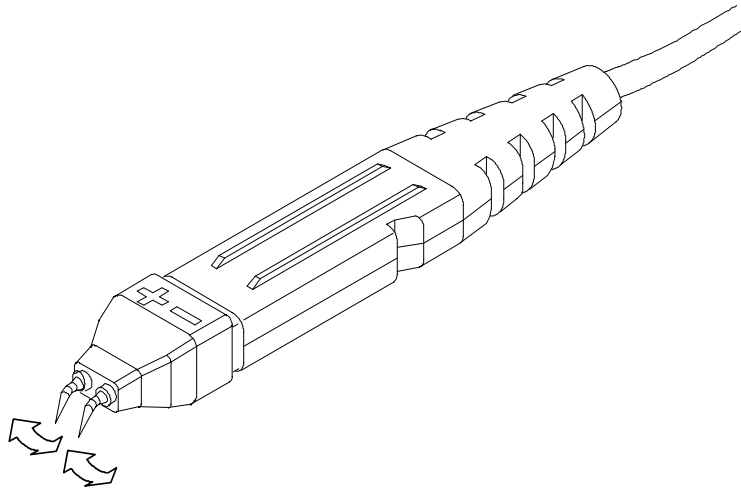

Figure 5: Using the variable spacing adapter

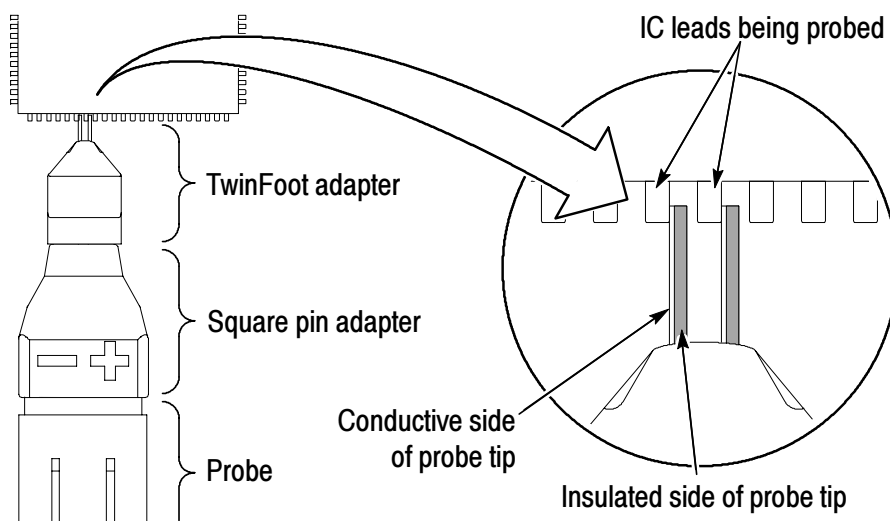

Figure 6: Using the TwinFoot adapter

Input Impedance and Probe Loading

When you connect the probe inputs to a circuit, you are introducing a new resistance, capacitance, and inductance into the circuit. Each input of the P7330 differential probe has a characteristic input impedance of $50\text{ k}\Omega$ to ground in parallel with less than 0.4 pF . See Figure 7.

For signals with low source impedance and frequency, the $50\text{ k}\Omega$ input impedance on each input is large enough to prevent the inputs from loading the signal sources. The greater the source impedances and the higher the signal frequencies, the more you must take these factors into account.

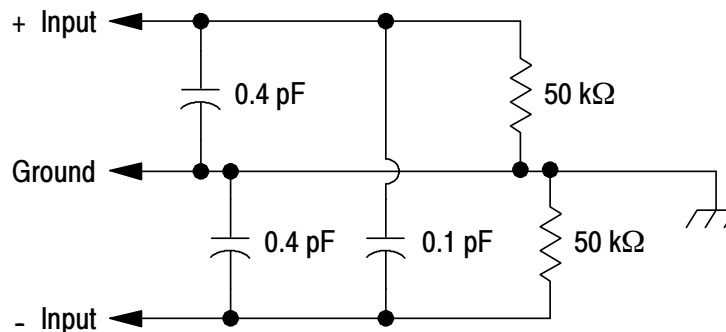

Figure 7: Typical probe input model

As the impedance of the signal source on an input increases, the more the probe loads the source and reduces the signal amplitude.

The frequency of the signal also affects signal measurement. As the frequency of the signal increases, the input impedance of the probe decreases. The lower the impedance of the probe relative to that of the source, the more the probe loads the circuit under test and reduces the signal amplitude. For a graph of frequency versus input impedance, refer to Figure 13 on page 24.

Probe Grounding

In addition to the plus and minus inputs on the probe head, there is also a ground (common) input. The ground lead slides into the notch on the side of the probe. See Figure 8.

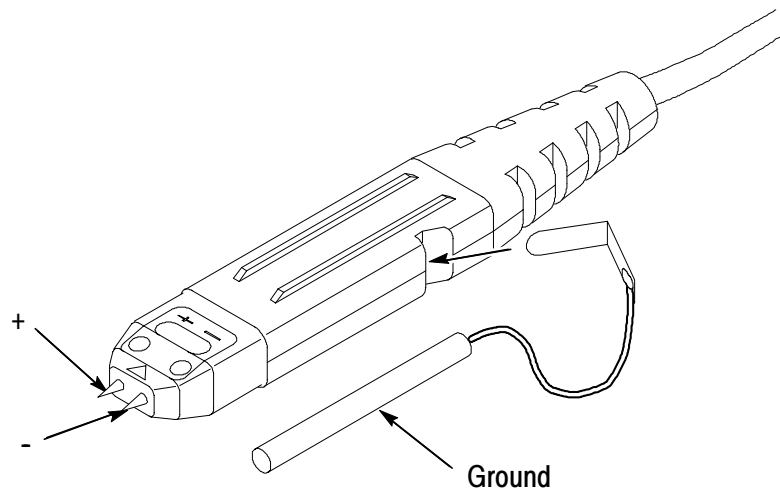

Figure 8: Probe ground input



CAUTION. To avoid damaging the circuitry under test, connect the probe ground (common), if used, to a ground-reference point only.

In most applications, the common-mode impedance to ground is greater than the differential impedance. Adding the probe ground lead does not improve the high-frequency performance of the measurement. You can use the probe to take a differential measurement regardless of whether or not the ground (common) is connected.

There are some applications that may require a ground reference connection to maintain measurement accuracy. Generally this is necessary when probing circuits which are fully isolated from ground, such as battery operated devices.

Electrical Effects of Accessories

The probe tip accessories included with your probe help connect to different types of components. While these accessories make connections easier, be aware that the adapter you choose may affect the signal you are measuring, depending on a variety of factors, including signal frequency, source impedance, and lead length.

Use the probe only (without adapters) to optimize step and frequency response. Using the probe tip adapters adds inductance and capacitance, which increases step response and aberrations, and leads to increased ripples in frequency response. These effects increase as the source impedance and the measured waveform risetimes decrease. Refer to page 23 for input capacitance specifications when using the variable spacing and square pin adapters.

The recommended method for hands-free probing is to use the probe only (without adapters), with a probe positioner such as a Tektronix PPM203B. If you need a tip space between 0.020 and 0.180 inches apart, use the variable spacing adapter and the probe positioner. Use the square pin adapter for test points or component leads spaced farther than 0.180 inches apart.

Figure 9 illustrates the typical effects on a given signal using some of the adapters included with your probe.

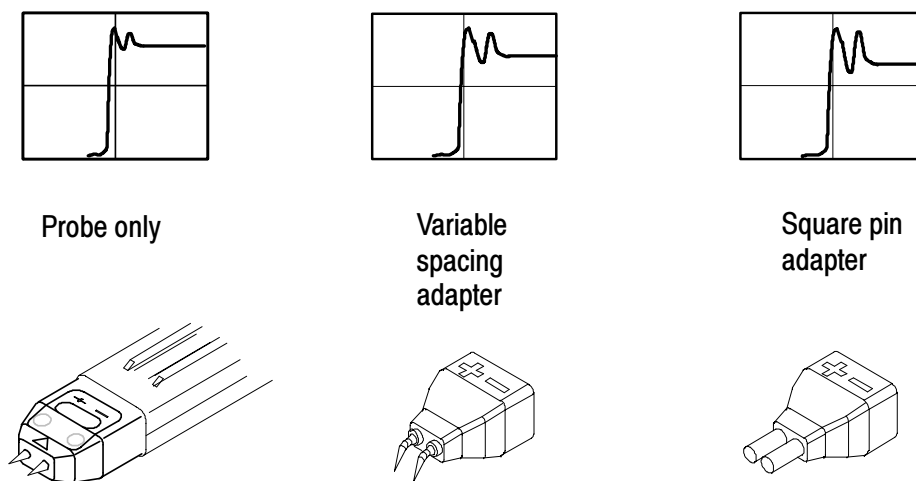

Figure 9: Typical effects on a signal using probe tip adapters

Reference

This section contains important reference information about differential measurements and how to increase the accuracy of your measurements.

Problems with Single-Ended Measurements

While suitable in many applications, single-ended measurements can present problems in the following situations:

- When the signal is not referenced to earth ground
- When the signal being measured is distorted or changed by connecting or disconnecting the probe ground reference lead

Differential Measurements

Devices designed to make differential measurements avoid the problems posed by single-ended systems. These devices include a variety of differential probes, differential amplifiers, and isolators.

The differential amplifier (Figure 10) is at the heart of any device or system designed to make differential measurements. Ideally, the differential amplifier rejects any voltage that is common to the inputs and amplifies any difference between the inputs. Voltage that is common to both inputs is often referred to as the Common-Mode Voltage (V_{CM}) and voltage that is different as the Differential-Mode Voltage (V_{DM}).

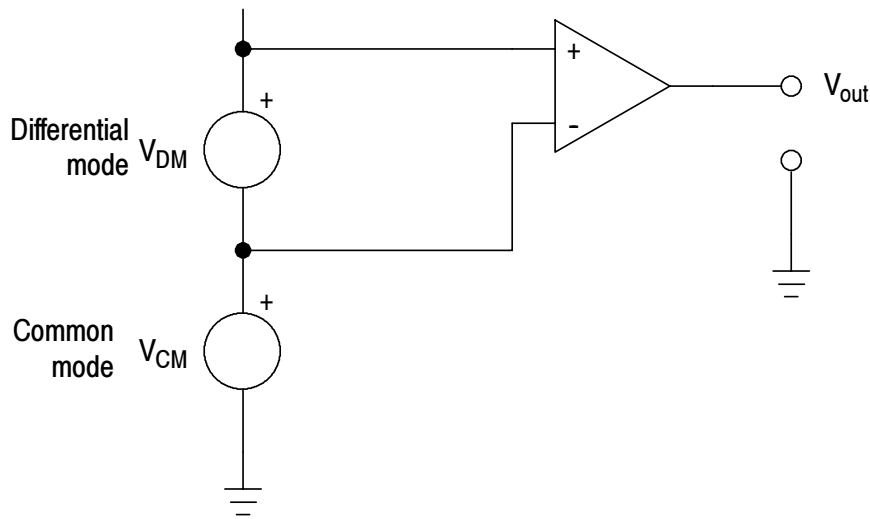

Figure 10: Simplified model of a differential amplifier

Common-Mode Rejection Ratio

In reality, differential amplifiers cannot reject all of the common-mode signal. The ability of a differential amplifier to reject the common-mode signal is expressed as the Common-Mode Rejection Ratio (CMRR). The CMRR is the differential-mode gain (A_{DM}) divided by the common-mode gain (A_{CM}). It is expressed either as a ratio or in dB.

$$CMRR = \frac{A_{DM}}{A_{CM}} \quad dB = 20 \log \frac{A_{DM}}{A_{CM}}$$

CMRR generally is highest (best) at DC and degrades with increasing frequency.

Assessing CMRR Error

Figure 12 on page 24 shows the CMRR of the P7330 differential probe. This derating chart assumes a common-mode signal that is sinusoidal.

A quick way to assess the magnitude of CMRR error when the common-mode signal is not sinusoidal is to connect both leads to the same point in the circuit. The oscilloscope will display only the common-mode component which is not fully rejected by the probe. While this technique may not give you entirely accurate measurements, it does allow you to determine if the magnitude of the common-mode error signal is significant.

Input Impedance Effects on CMRR

The lower the input impedance of the probe relative to the source impedance, the lower the CMRR. See Figure 12 on page 24. Significant differences in the source impedance driving the two inputs will also lower the CMRR.

Extending the Input Leads

At times it may be necessary to extend the probe inputs with wires or a probe tip adapter. When you do this, you should minimize the lead lengths to optimize common-mode rejection and twist the input leads together as shown in Figure 11.

Twisting the input leads together does increase capacitance that may degrade high-frequency performance. You should take into account any effects caused by the extended leads when you take a measurement.

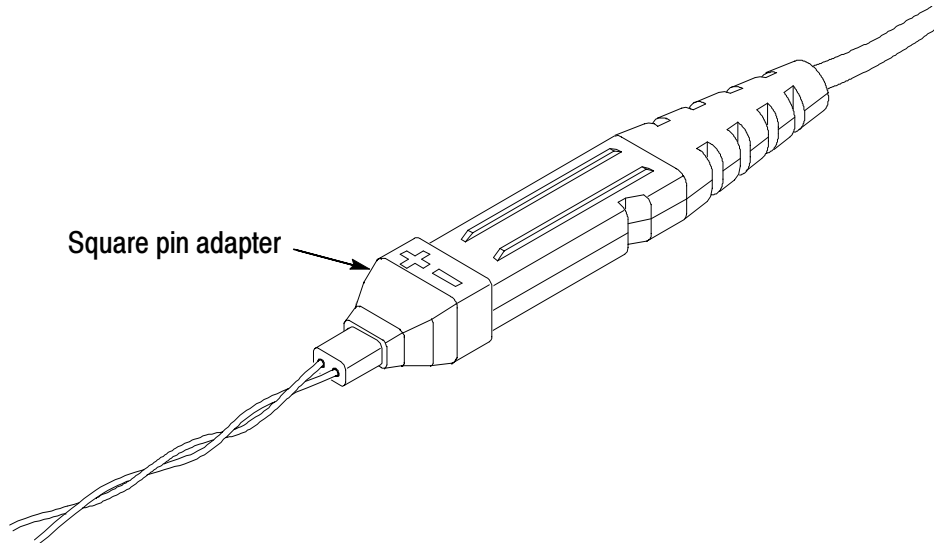

Figure 11: Twisting the input leads

Extending the Ground Lead

Extending the ground lead will have little, if any, affect on your measurements. In most circuits, the ground path from the differential source has sufficiently high impedance to damp out any ringing caused by lead inductance.

Appendix A: Specifications

The specifications in Tables 3 through 6 apply to a P7330 probe installed on a TDS7404 oscilloscope. The probe must have a warm-up period of at least 20 minutes and be in an environment that does not exceed the limits described in Table 3. Specifications for the P7330 differential probe fall into three categories: warranted, typical, and nominal characteristics.

Warranted Characteristics

Warranted characteristics (Table 3) describe guaranteed performance within tolerance limits or certain type-tested requirements.

Warranted characteristics that have checks in the *Performance Verification* section are marked with the ✓ symbol.

Table 3: Warranted electrical characteristics

Characteristic	Description
✓ Rise time (probe only)	140 ps (130 ps typical)
✓ DC gain	0.2 ±2%
✓ Output offset voltage	±10 mV +20° C to +30° C (+68° F to +86° F) ±50 mV displayed on screen with TekConnect interface
Maximum nondestructive input voltage	±15 V(DC + peak AC) between signal and common of the same channel.
Delay variation (probe-to-probe)	600 ps maximum
Temperature	Operating: 0 to +40° C (+32 to +104° F) Nonoperating: -55 to +75° C (-131 to +167° F) ¹

Table 3: Warranted electrical characteristics (Cont.)

Characteristic	Description
Humidity	Operating: 0-90% RH, tested at +30 to +40° C (+68 to +104° F) Nonoperating: 0-90% RH, tested at +30 to +60° C (+68 to +140° F)

¹ See warning that follows.



WARNING. To avoid a burn hazard at high ambient temperatures, do not touch the probe with bare hands at nonoperating temperatures above + 70° C. Allow sufficient time for the probe to cool before handling.

Typical Characteristics

Typical characteristics (Tables 4 and 5) describe typical but not guaranteed performance.

Table 4: Typical electrical characteristics

Characteristic	Description
Bandwidth (probe only)	DC to ≥ 3.5 GHz (- 3dB)
Differential signal range	± 2.0 V
Differential offset range	± 1 V
Linearity	$\pm 1\%$ or less of dynamic range
Common-mode signal range	+5 V to -4 V
Common-mode rejection ratio	≥ 60 dB at DC ≥ 55 dB at 1 MHz ≥ 45 dB at 30 MHz ≥ 25 dB at 1 GHz

Table 4: Typical electrical characteristics (Cont.)

Characteristic	Description
Delay time	5.53 ns
Differential input resistance, DC coupled	100 k Ω \pm 2%
Differential input capacitance:	
probe only	<0.3 pF @100 MHz
probe with variable spacing adapter (P/N 016-1885-00)	<0.45 pF @100 MHz
probe with square pin adapter (P/N 016-1884-00)	<0.55 pF @100 MHz
Common-mode input resistance, DC coupled	50 k Ω \pm 2% (per side)
Common-mode input capacitance	<0.45 pF @100 MHz (per side)
Input impedance	See Figure 13
Noise, referred to input	35 nV/ $\sqrt{\text{Hz}}$ @100 MHz
DC Offset Scale Accuracy (gain of offset signal path)	\pm 2.0%
DC Offset Drift	150 $\mu\text{V}/^\circ\text{C}$ or less at output of probe 0.75 mV/ $^\circ\text{C}$ or less displayed on screen with TekConnect interface
DC Voltage Measurement Accuracy (referred to input)	\pm [2% of input + (2% of offset) + 50.0 mV + 40.0 mV] gain error = \pm 2% of input voltage offset gain error = \pm 2% of effective offset at probe tip output zero = \pm 50 mV effective at probe tip linearity error = \pm 1.0% of 4.0 V dynamic range (40.0 mV)

Figure 12 shows the typical common-mode gain of the probe. The CMRR can be approximated by subtracting the common-mode gain from the -14 dB reference level. For example, -80 dB CM gain equals +66 dB CMRR.

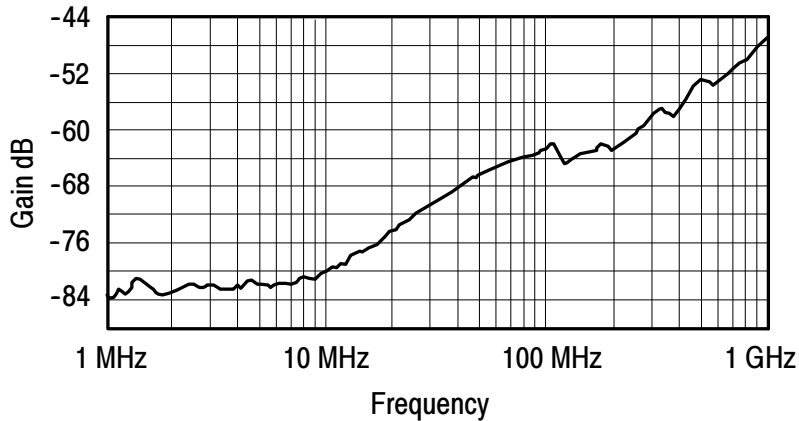

Figure 12: Typical common-mode gain

The graph in Figure 13 represents simulation results of a first order model of the probe input.

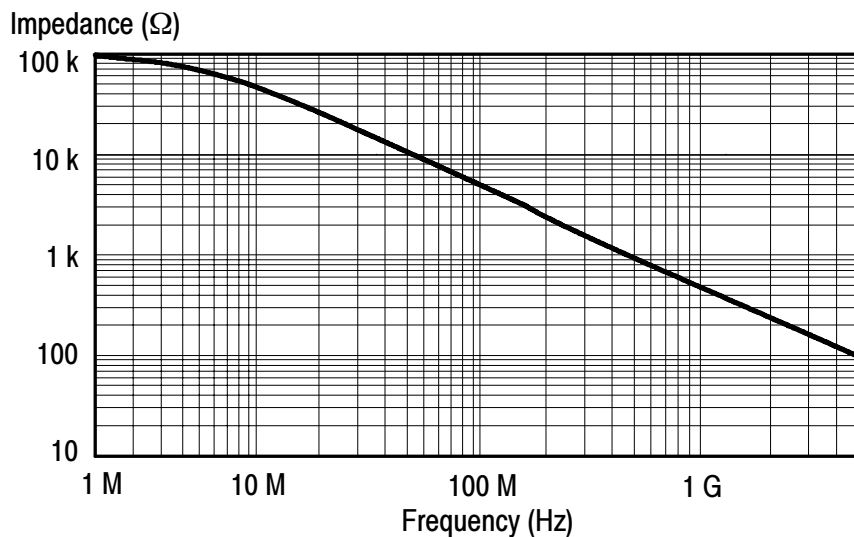

Figure 13: Typical differential input impedance vs frequency

Table 5: Typical mechanical characteristics

Dimensions, control box	91.5 mm × 43.8 mm × 31.8 mm (3.60 in × 1.725 in × 1.25 in)
Dimensions, probe head	59 mm × 7.7 mm × 5.1 mm (2.30 in × 0.30 in × 0.20 in)
Dimensions, output cable	1.2 m (47 in)
Unit weight (probe only)	223 g (7.5 oz)

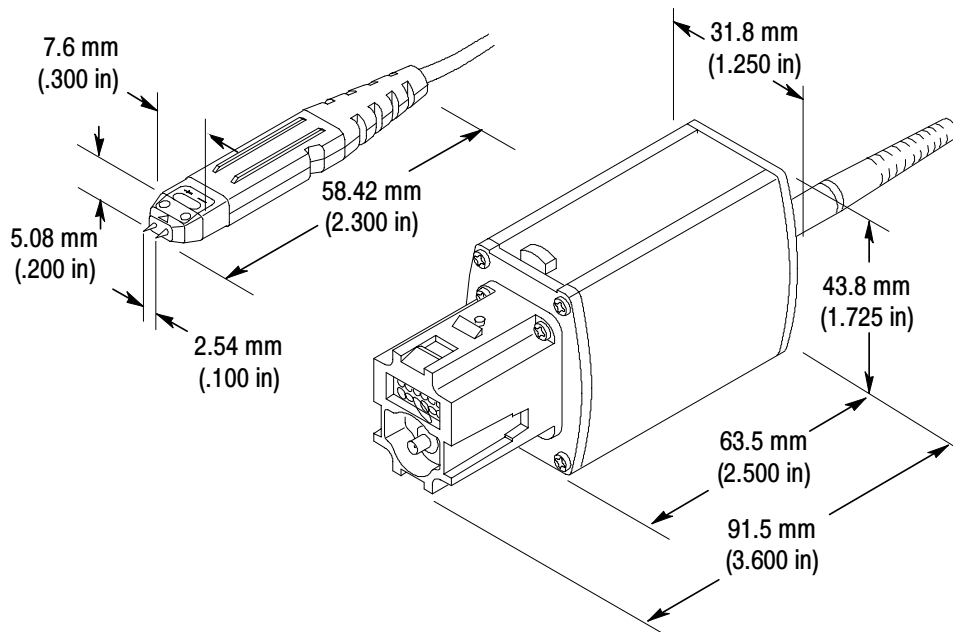

Figure 14: Probe head and compensation box dimensions

Nominal Characteristics

Nominal characteristics (Table 6) describe guaranteed traits, but the traits do not have tolerance limits.

Table 6: Nominal electrical characteristics

Input configuration	Differential (two inputs, + and -), with case ground
Attenuation	5X
Input coupling	DC
Termination	Terminate output into 50 Ω

Appendix B: User Service

This section details the maintenance for the P7330 differential probe.

Inspection and Cleaning

Protect the probe from adverse weather conditions. The probe is not waterproof.



CAUTION. *To prevent damage to the probe, do not expose it to sprays, liquids, or solvents. Do not use chemical cleaning agents; they may damage the probe. Avoid using chemicals that contain benzene, benzene, toluene, xylene, acetone, or similar solvents.*

Clean the exterior surfaces of the probe with a dry, lint-free cloth or a soft-bristle brush. If dirt remains, use a soft cloth or swab dampened with a 75% isopropyl alcohol solution. A swab is useful for cleaning narrow spaces on the probe. Do not use abrasive compounds on any part of the probe.



CAUTION. *Avoid getting moisture inside the probe during exterior cleaning and use only enough solution to dampen the swab or cloth. Use a 75% isopropyl alcohol solution as a cleanser, and rinse with deionized water.*

Replacement Parts

Refer to the *Replaceable Parts* section for a list of customer replacement parts. Due to the sophisticated design of the P7330 differential probe, there are no user replaceable parts within the probe.

Performance Verification and Adjustments

If you need to do a performance verification or make internal adjustments to your probe, refer to the *P7330 3.5 GHz Differential Probe Service Manual*, Tektronix part number 071-1057-XX. The manual is a printable pdf file, and is available on both the Tektronix website and the Optional Applications CD that is included with Tektronix oscilloscopes featuring the TekConnect interface.

Preparation for Shipment

If the original packaging is unfit for use or not available, use the following packaging guidelines:

1. Use a corrugated cardboard shipping carton having inside dimensions at least one inch greater than the probe dimensions. The box should have a carton test strength of at least 200 pounds.
2. Put the probe into an antistatic bag or wrap to protect it from dampness.
3. Place the probe into the box and stabilize it with light packing material.
4. Seal the carton with shipping tape.



Appendix C: Replaceable Parts

This section contains a list of replaceable parts for the P7330 differential probe. Use this list to identify and order replacement parts.

Parts Ordering Information

Replacement parts are available from or through your local Tektronix, Inc. service center or representative.

Changes to Tektronix instruments are sometimes made to accommodate improved components as they become available and to give you the benefit of the latest circuit improvements. Therefore, when ordering parts, it is important to include the following information in your order:

- Part number
- Instrument type or model number
- Instrument serial number
- Instrument modification number, if applicable

If a part you order has been replaced with a different or improved part, your local Tektronix service center or representative will contact you concerning any change in the part number.

Using the Replaceable Parts List

The tabular information in the Replaceable Parts List is arranged for quick retrieval. Understanding the structure and features of the list will help you find the information you need for ordering replacement parts.

Item Names

In the Replaceable Parts List, an Item Name is separated from the description by a colon (:). Because of space limitations, an Item Name may sometimes appear as incomplete. For further Item Name identification, U.S. Federal Cataloging Handbook H6-1 can be used where possible.

Indentation System

This parts list is indented to show the relationship between items. The following example is of the indentation system used in the Description column:

<i>1</i>	<i>2</i>	<i>3</i>	<i>4</i>	<i>5</i>	<i>Name & Description</i>
					<i>Assembly and/or Component</i>
					<i>Attaching parts for Assembly and/or Component</i>
					<i>(END ATTACHING PARTS)</i>
					<i>Detail Part of Assembly and/or Component</i>
					<i>Attaching parts for Detail Part</i>
					<i>(END ATTACHING PARTS)</i>
					<i>Parts of Detail Part</i>
					<i>Attaching parts for Parts of Detail Part</i>
					<i>(END ATTACHING PARTS)</i>

Attaching parts always appear at the same indentation as the item it mounts, while the detail parts are indented to the right. Indented items are part of, and included with, the next higher indentation. Attaching parts must be purchased separately, unless otherwise specified.

Abbreviations

Abbreviations conform to American National Standards Institute (ANSI) standard Y1.1

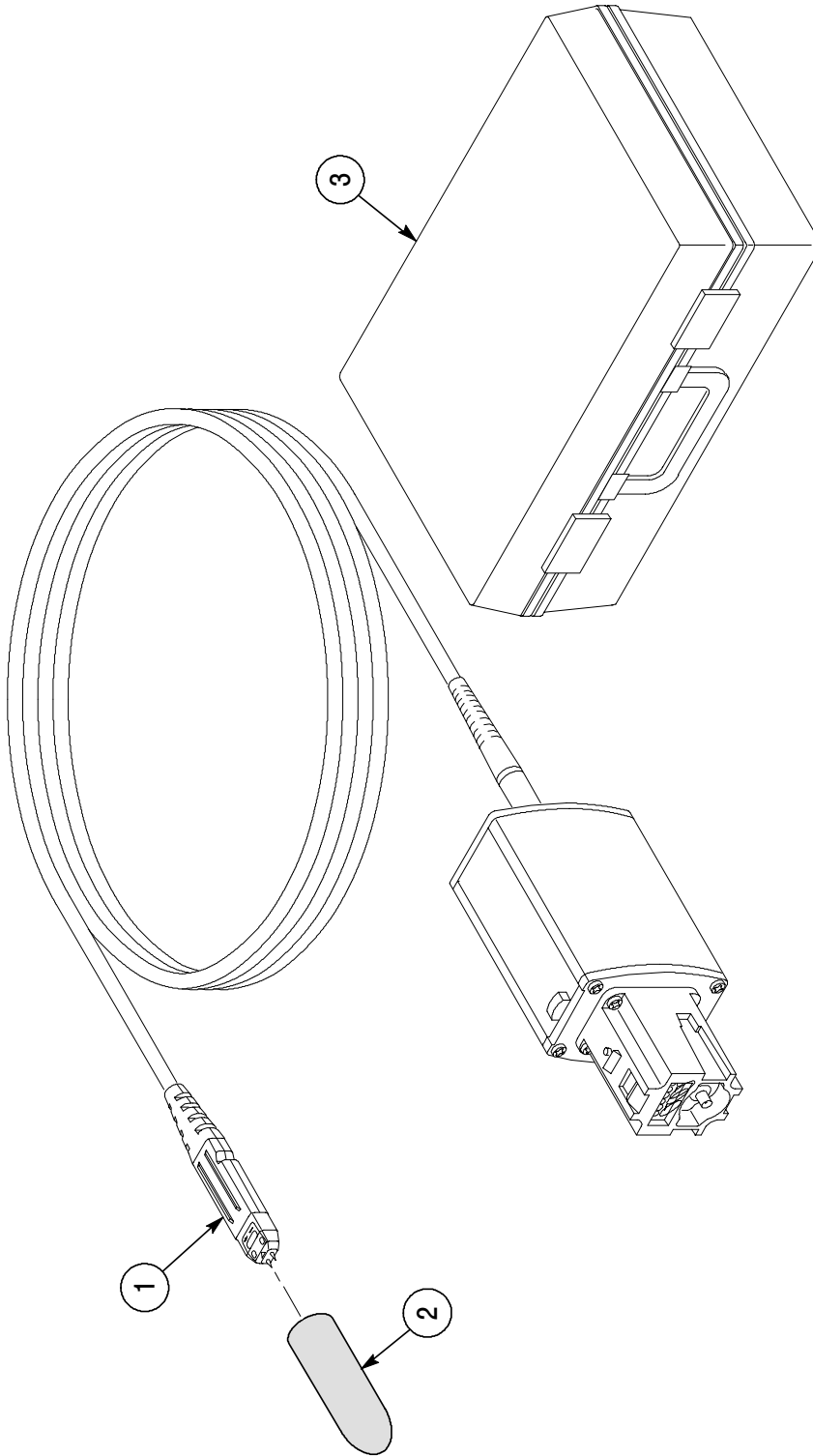

Figure 15: P7330 replaceable parts

Appendix C: Replaceable Parts

Fig. & index no.	Tektronix part no.	Serial no. Effective	Qty	12345 name & description	Mfr. code	Mfr. part no.
15-1	010-0641-04		1	PROBE ASSEMBLY:SERVICE REPLACEMENT, SERIALIZED	80009	010-0641-04
-2	200-4236-00		1	COVER, PROBE TIP	80009	200-4236-00
-3	016-1879-XX		1	CASE,STORAGE:PLASTIC, W/ANTISTAT FOAM	TK6108	016-1879-XX

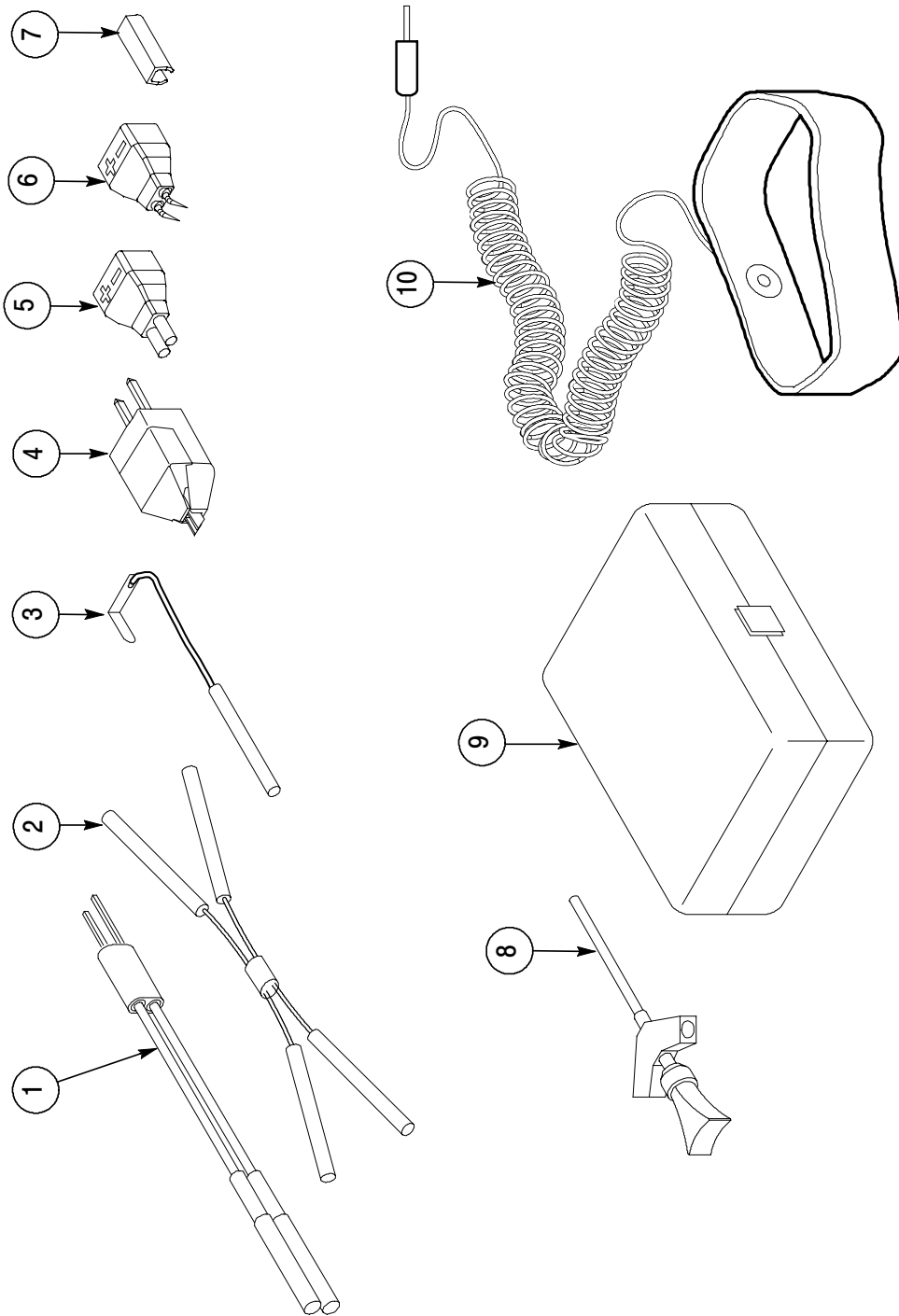

Figure 16: P7330 standard accessories

Appendix C: Replaceable Parts

Fig. & index no.	Tektronix part no.	Serial no. Effective	Qty	12345 name & description	Mfr. code	Mfr. part no.
STANDARD ACCESSORIES						
16-1	196-3468-00		1	LEAD, ELEC:DESCRETE, CPD,2,22 AWG, RED & BLACK,2.300 L,JACK TIP,PKG OF 2	060D9	196-3468-00
-2	196-3473-00		2	LEAD,PIN JUMPER:DIFF,FEMALE SQ PIN CONNECTOR TO FEMALE SQ PIN CONNECTOR,23 AWG,3.0 L	060D9	196-3473-00
-3	196-3469-00		1	LEAD GROUND:GROUND LEAD,PKG OF 2		196-3469-00
-4	016-1785-00		1	ADAPTER:DIFFERENTIAL PROBE,PKG OF 4	80009	016-1785-00
-5	016-1884-00		1	ACCESSORY KIT:SQUARE PIN ADAPTER,PKG OF 4	060D9	016-1884-00
-6	016-1885-00		1	ACCESSORY KIT:VARIABLE SPACER ADAPTER,PKG OF 4	060D9	016-1885-00
-7	016-1315-00		1	MARKER KIT,ID:CABLE MARKER BAND,2 EA, VAR COLRS	80009	016-1315-00
-8	206-0364-XX		2	TIP,PROBE:MICROCKT TEST,SMT KLIPCHIP	80009	206-0364-XX
-9	006-7164-00		1	BOX,PLASTIC:4.625 X 2.875 X 1.0	80009	006-7164-00
-10	006-3415-04		1	STRAP,WRIST:3M TYPE 2214, ADJUSTABLE,6 FT COILED CORD	TK0623	RTI 8454001829
	071-0758-XX		1	MANUAL,TECH:USER,P7330	80009	071-0758-XX

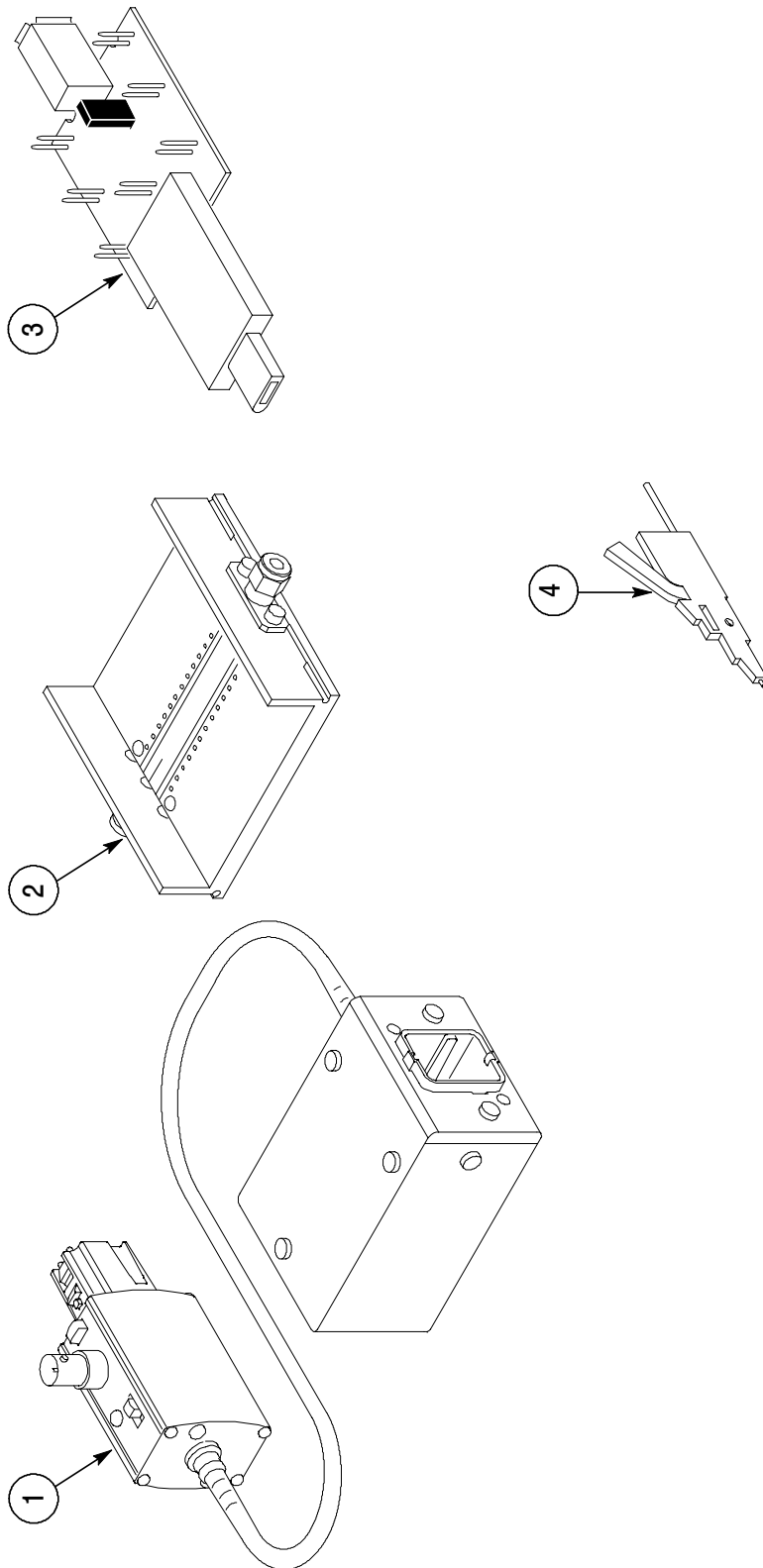

Figure 17: P7330 optional accessories

Appendix C: Replaceable Parts

Fig. & index no.	Tektronix part no.	Serial no. Effective	Dscont	Qty	12345 name & description	Mfr. code	Mfr. part no.
OPTIONAL ACCESSORIES							
17	-1 067-0422-00			1	CALIBRATION FIXTURE ASSY:ECB TO TOP,P7000 SERIES	80009	067-0422-00
	-2 067-0419-00			1	PROBE CALIBRATION FIXTURE	80009	067-0419-00
	-3 679-5027-00			1	CKT BD SUBASSY:1394 ADAPTER	80009	679-5027-00
	-4 SMK4			1	TIP,PROBE:MICROCKT TEST,PKG OF 4	80009	SMK4

CROSS INDEX - MFR. CODE NUMBER TO MANUFACTURER

Mfr. code	Manufacturer	Address	City, state, zip code
060D9	UNITREK CORPORATION	3000 COLUMBIA HOUSE BLVD, SUITE 120	VANCOUVER, WA 98661
26805	M/A COM OMNI SPECTRA INC	MICROWAVE CONNECTOR DIV 140 4TH AVE	WALTHAM, MA 02254
80009	TEKTRONIX INC	14150 SW KARL BRAUN DR PO BOX 500	BEAVERTON, OR 97077-0001
TK0623	GENERAL TOOL & SUPPLY CO	2705 NW NICOLAI ST	PORTLAND, OR 97210
TK2565	VISION PLASTICS INC	26000 SW PARKWAY CENTER DRIVE	WILSONVILLE, OR 97070
TK6108	KENT H LANDSBERG CO	27929 SW 95TH, SUITE 101	WILSONVILLE, OR 97070

