



ABN 43 064 478 842

➤ 231 Osborne Avenue Clayton South, VIC 3169  
 PO Box 1548, Clayton South, VIC 3169  
 t 03 9265 7400 f 03 9558 0875  
 freecall 1800 680 680  
[www.tmgtestequipment.com.au](http://www.tmgtestequipment.com.au)

## Test & Measurement

- sales
- rentals
- calibration
- repair
- disposal

## Complimentary Reference Material

This PDF has been made available as a complimentary service for you to assist in evaluating this model for your testing requirements.

TMG offers a wide range of test equipment solutions, from renting short to long term, buying refurbished and purchasing new. Financing options, such as Financial Rental, and Leasing are also available on application.

TMG will assist if you are unsure whether this model will suit your requirements.

Call TMG if you need to organise repair and/or calibrate your unit.

If you click on the “Click-to-Call” logo below, you can call us for FREE!

TMG Corporate Website

TMG Products Website



Click-to-Call  
TMG Now



Product Lifecycle Management System

**Disclaimer:**

All trademarks appearing within this PDF are trademarks of their respective owners.



# Instruction Manual



## **P7350** **5 GHz Differential Probe** **071-1238-00**

### **Warning**

The servicing instructions are for use by qualified personnel only. To avoid personal injury, do not perform any servicing unless you are qualified to do so. Refer to all safety summaries prior to performing service.

**[www.tektronix.com](http://www.tektronix.com)**

Copyright © Tektronix, Inc. All rights reserved.

Tektronix products are covered by U.S. and foreign patents, issued and pending. Information in this publication supercedes that in all previously published material. Specifications and price change privileges reserved.

Tektronix, Inc., P.O. Box 500, Beaverton, OR 97077

TEKTRONIX, TEK, SureFoot, and TekConnect are registered trademarks of Tektronix, Inc., and KlipChip is a trademark of Tektronix, Inc.

## WARRANTY

Tektronix warrants that the products that it manufactures and sells will be free from defects in materials and workmanship for a period of one (1) year from the date of shipment. If a product proves defective during this warranty period, Tektronix, at its option, either will repair the defective product without charge for parts and labor, or will provide a replacement in exchange for the defective product.

In order to obtain service under this warranty, Customer must notify Tektronix of the defect before the expiration of the warranty period and make suitable arrangements for the performance of service. Customer shall be responsible for packaging and shipping the defective product to the service center designated by Tektronix, with shipping charges prepaid. Tektronix shall pay for the return of the product to Customer if the shipment is to a location within the country in which the Tektronix service center is located. Customer shall be responsible for paying all shipping charges, duties, taxes, and any other charges for products returned to any other locations.

This warranty shall not apply to any defect, failure or damage caused by improper use or improper or inadequate maintenance and care. Tektronix shall not be obligated to furnish service under this warranty a) to repair damage resulting from attempts by personnel other than Tektronix representatives to install, repair or service the product; b) to repair damage resulting from improper use or connection to incompatible equipment; c) to repair any damage or malfunction caused by the use of non-Tektronix supplies; or d) to service a product that has been modified or integrated with other products when the effect of such modification or integration increases the time or difficulty of servicing the product.

**THIS WARRANTY IS GIVEN BY TEKTRONIX IN LIEU OF ANY OTHER WARRANTIES, EXPRESS OR IMPLIED. TEKTRONIX AND ITS VENDORS DISCLAIM ANY IMPLIED WARRANTIES OF MERCHANTABILITY OR FITNESS FOR A PARTICULAR PURPOSE. TEKTRONIX' RESPONSIBILITY TO REPAIR OR REPLACE DEFECTIVE PRODUCTS IS THE SOLE AND EXCLUSIVE REMEDY PROVIDED TO THE CUSTOMER FOR BREACH OF THIS WARRANTY. TEKTRONIX AND ITS VENDORS WILL NOT BE LIABLE FOR ANY INDIRECT, SPECIAL, INCIDENTAL, OR CONSEQUENTIAL DAMAGES IRRESPECTIVE OF WHETHER TEKTRONIX OR THE VENDOR HAS ADVANCE NOTICE OF THE POSSIBILITY OF SUCH DAMAGES.**





# Preface

This is the Instruction Manual for the P7350 differential probe. This manual provides operating information, specifications, and a replaceable parts list.

## Contacting Tektronix

<b>Phone</b>	1-800-833-9200*
<b>Address</b>	Tektronix, Inc. Department or name (if known) 14200 SW Karl Braun Drive P.O. Box 500 Beaverton, OR 97077 USA
<b>Web site</b>	<a href="http://www.tektronix.com">www.tektronix.com</a>
<b>Sales support</b>	1-800-833-9200, select option 1*
<b>Service support</b>	1-800-833-9200, select option 2*
<b>Technical support</b>	Email: <a href="mailto:techsupport@tektronix.com">techsupport@tektronix.com</a> 1-800-833-9200, select option 3* 6:00 a.m. - 5:00 p.m. Pacific time

---

\* **This phone number is toll free in North America. After office hours, please leave a voice mail message. Outside North America, contact a Tektronix sales office or distributor; see the Tektronix web site for a list of offices.**

# Table of Contents

<b>Preface</b> .....	<b>i</b>
Contacting Tektronix .....	ii
General Safety Summary .....	v
Service Safety Summary .....	vii
<b>Getting Started</b> .....	<b>1</b>
TekConnect Interface .....	1
Functional Check .....	3
Options .....	4
Features and Standard Accessories .....	5
Optional Accessories .....	9
<b>Operating Basics</b> .....	<b>11</b>
Input Voltage Limits .....	12
Common-Mode Rejection .....	12
Probing Techniques to Maximize CMRR .....	13
Input Impedance and Probe Loading .....	14
Probe Grounding .....	15
Electrical Effects of Accessories .....	16
<b>Reference</b> .....	<b>17</b>
Problems with Single-Ended Measurements .....	17
Differential Measurements .....	17
Extending the Input Leads .....	19
Extending the Ground Lead .....	20
<b>Appendix A: Specifications</b> .....	<b>21</b>
<b>Appendix B: Performance Verification</b> .....	<b>29</b>
<b>Appendix C: Maintenance</b> .....	<b>43</b>
<b>Appendix D: Replaceable Parts</b> .....	<b>45</b>



## List of Figures

Figure 1: P7350 differential probe featuring the TekConnect interface .....	1
Figure 2: Connecting and disconnecting the probe .....	2
Figure 3: Probe functional check connections .....	3
Figure 4: Protect the probe tips with the protective cover .....	11
Figure 5: Using the variable spacing adapter .....	13
Figure 6: Using the TwinFoot adapter .....	13
Figure 7: Typical probe input model .....	14
Figure 8: Probe ground input .....	15
Figure 9: Typical effects on a signal using probe tip adapters ..	16
Figure 10: Simplified model of a differential amplifier .....	18
Figure 11: Twisting the input leads .....	20
Figure 12: Typical common- and differential-mode gain plots	24
Figure 13: Typical differential input impedance vs frequency ..	25
Figure 14: Typical bandwidth .....	25
Figure 15: Probe head and compensation box dimensions .....	27
Figure 16: Variable spacing adapter dimensions .....	28
Figure 17: Square pin adapter dimensions .....	28
Figure 18: TekConnect Interface Calibration Adapter .....	31
Figure 19: Probe Calibration Fixture .....	33
Figure 20: Probe Calibration Fixture test points .....	34
Figure 21: Setup for the output offset voltage test .....	35
Figure 22: DC Gain Accuracy setup .....	36
Figure 23: Test system rise time setup .....	38
Figure 24: Test system rise time setup with probe .....	40
Figure 25: Verifying both probe pins are contacting the DM test points .....	41
Figure 26: P7350 replaceable parts .....	47
Figure 27: P7350 standard accessories .....	49
Figure 28: P7350 optional accessories .....	51



# General Safety Summary

Review the following safety precautions to avoid injury and prevent damage to this product or any products connected to it. To avoid potential hazards, use this product only as specified.

## To Avoid Fire or Personal Injury

**Connect and Disconnect Properly.** Connect the probe output to the measurement instrument before connecting the probe to the circuit under test. Disconnect the probe input and the probe ground from the circuit under test before disconnecting the probe from the measurement instrument.

**Observe All Terminal Ratings.** To avoid fire or shock hazard, observe all ratings and markings on the product. Consult the product manual for further ratings information before making connections to the product.

The common terminal is at ground potential. Do not connect the common terminal to elevated voltages.

**Do Not Operate Without Covers.** Do not operate this product with covers or panels removed.

**Do Not Operate With Suspected Failures.** If you suspect there is damage to this product, have it inspected by qualified service personnel.

**Do Not Operate in Wet/Damp Conditions.**

**Do Not Operate in an Explosive Atmosphere.**

**Keep Product Surfaces Clean and Dry.**

## Safety Terms and Symbols

**Terms in This Manual.** These terms may appear in this manual:



---

**WARNING.** *Warning statements identify conditions or practices that could result in injury or loss of life.*

---



---

**CAUTION.** *Caution statements identify conditions or practices that could result in damage to this product or other property.*

---

**Terms on the Product.** These terms may appear on the product:

DANGER indicates an injury hazard immediately accessible as you read the marking.

WARNING indicates an injury hazard not immediately accessible as you read the marking.

CAUTION indicates a hazard to property including the product.

**Symbols on the Product.** These symbols may appear on the product:



CAUTION  
Refer to Manual



## Service Safety Summary

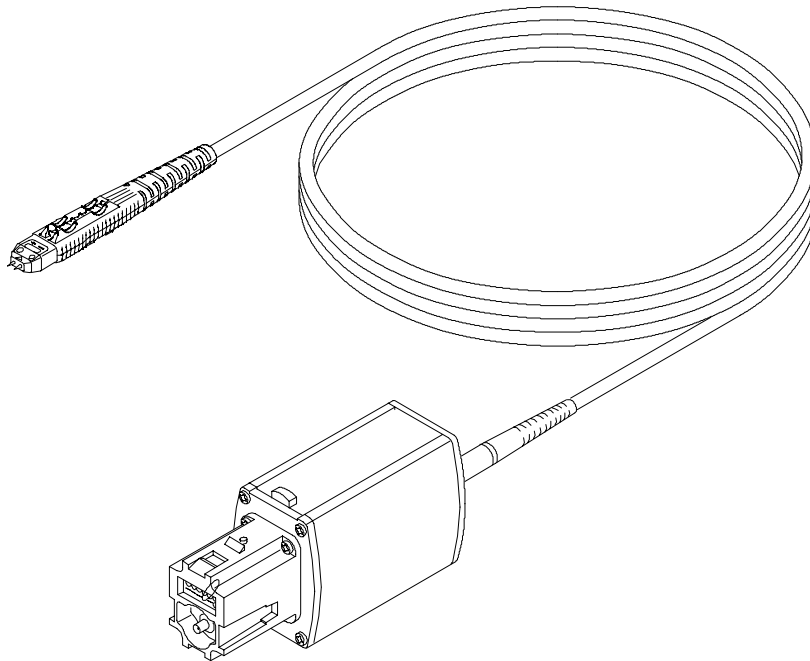
Only qualified personnel should perform service procedures. Read this *Service Safety Summary* and the *General Safety Summary* before performing any service procedures.

**Do Not Service Alone.** Do not perform internal service or adjustments of this product unless another person capable of rendering first aid and resuscitation is present.



# Getting Started

The P7350 is a high-bandwidth (5 GHz typical), active differential probe with a miniaturized probe head design. The probe has low circuit loading, high common-mode rejection, and ships with a variety of accessories for connecting to surface-mount devices and other components.



**Figure 1: P7350 differential probe featuring the TekConnect interface**

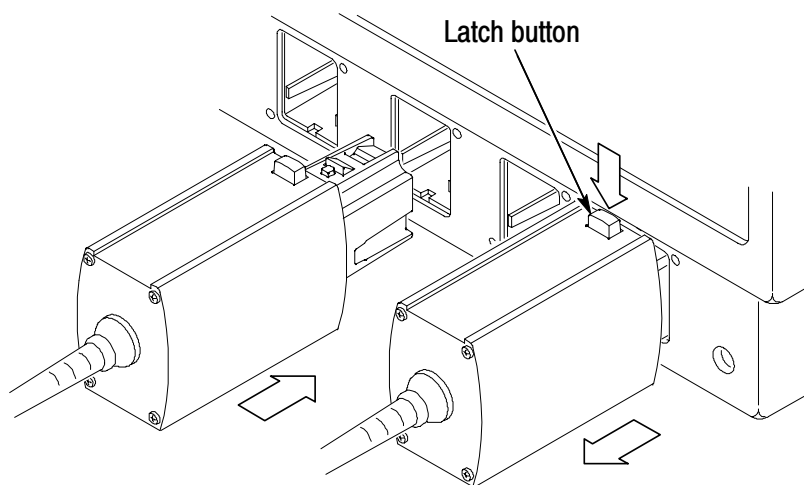
## TekConnect Interface

The P7350 probe is powered through a TekConnect interface between the probe compensation box and the host instrument. The TekConnect interface provides a communication path through contact pins on the host instrument. Power, signal, offset, and probe characteristic data transfer through the interface.

When the probe is connected, the host instrument reads EEPROM information from the probe, identifying the device and allowing the appropriate power supplies to be turned on. The preamp inputs on the host instrument are ESD protected by remaining grounded until a valid TekConnect device is detected.

The TekConnect interface features a spring-loaded latch that provides audible and tactile confirmation that a reliable connection has been made to the host instrument. Slide the probe into the TekConnect receptacle on the host instrument. The probe snaps into the receptacle when fully engaged. See Figure 2.

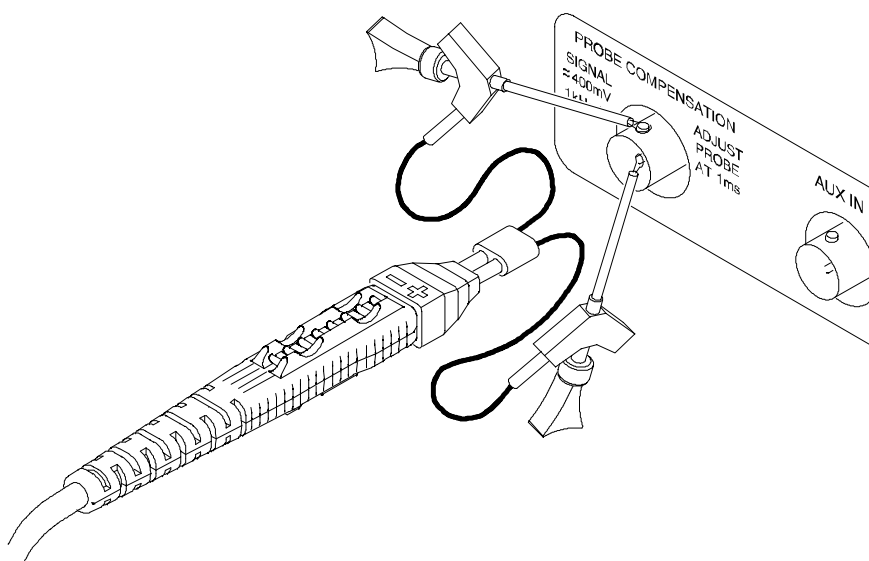
To release the probe from the host instrument, grasp the compensation box, press the latch button, and pull out the probe.



**Figure 2: Connecting and disconnecting the probe**

## Functional Check

After installing the probe on the oscilloscope, a functional check may be performed using the PROBE COMPENSATION connections on the front panel of the oscilloscope. Figure 3 shows a method for connecting the probe to a typical compensation connector.



**Figure 3: Probe functional check connections**

1. Connect the probe to the oscilloscope.
2. Set the oscilloscope to display the probe channel.
3. Connect the square pin adapter to the probe tip, and connect the Y-lead adapter to the square pin adapter. Plug the SMT KlipChips into the Y-lead adapter.
4. Connect the SMT KlipChips to the PROBE COMPENSATION connections on the oscilloscope.
5. Adjust the oscilloscope to display a stable calibration waveform.



---

**NOTE.** *If your instrument supports probe calibration routines, now is a good time to perform them.*

---

6. Disconnect the probe from the PROBE COMPENSATION connector, and connect the two KlipChips together.
7. With the probe offset set to 0.0 V, the oscilloscope display should be at the ground reference.
8. Set the oscilloscope volts/division to 500 mV.
9. Adjust the probe offset. The displayed waveform should vary between approximately +1.25 V and -1.25 V.

## Options

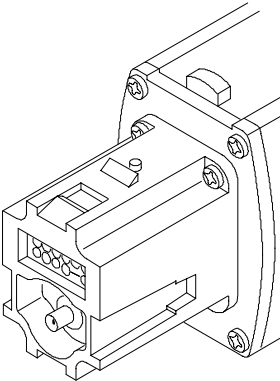
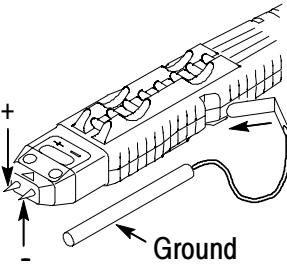
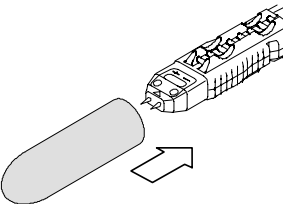
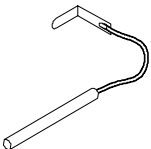
The following options are available when ordering the P7350 probe:

- Option D1-Calibration Data Report
- Option D3-Calibration Data Report, 3 years (with Option C3)
- Option C3-Calibration Service 3 years
- Option D5-Calibration Data Report, 5 years (with Option C5)
- Option C5-Calibration Service 5 years
- Option R3-Repair Service 3 years
- Option R5-Repair Service 5 years

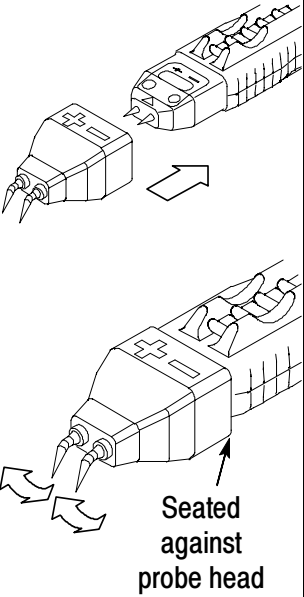
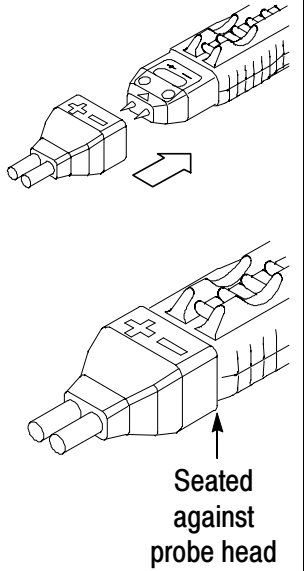
## Features and Standard Accessories

Table 1 shows the features and standard accessories of the P7350 differential probe.

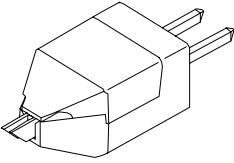
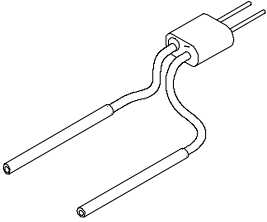
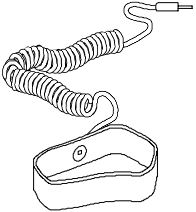
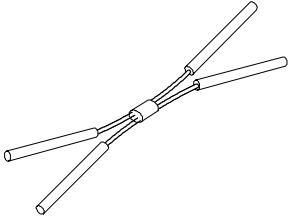
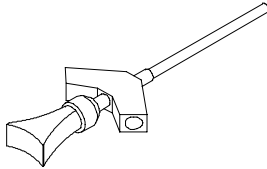
**Table 1: P7350 features and standard accessories**

Feature/Accessory	Description
	<p><b>TekConnect interface.</b> The TekConnect interface provides a communication path between the probe and the oscilloscope. Contact pins provide power, signal, offset, and probe characteristic data transfer.</p> <p>The probe snaps into the oscilloscope when fully engaged. To remove, grasp the compensation box, press the latch button, and pull the probe out.</p>
	<p><b>Input connections.</b> The plus and minus connections on the probe tip accept the standard and optional probe accessories. (Some of the accessories connect to the probe tip through the square pin adapter.) The ground lead connects to the probe head through a slot in the side of the insulated probe housing.</p> <p><b>WARNING:</b> Skin penetration hazard. To prevent injury, install the probe tip cover when the probe is not in use. The probe tips are extremely sharp to ensure good contact and measurement integrity.</p>
	<p><b>Probe tip cover.</b> The probe tip cover is shipped on the probe. The probe tips are extremely sharp to ensure good contact and measurement integrity. When not using the probe, slide the probe tip cover over the probe head to prevent damage to the probe tips and to protect yourself from personal injury.</p> <p>Tektronix part number: 200-4236-XX</p>
	<p><b>Three-inch ground lead (2 ea).</b> Use the ground lead for connecting the probe ground to the circuit, if needed. The socketed end of the lead may be connected to accessories, or fitted onto 0.025-inch square pins.</p> <p>Tektronix part number: 196-3469-XX (package of 2)</p>

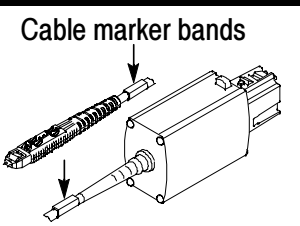
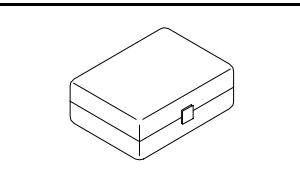
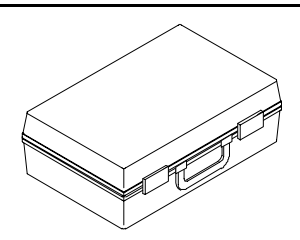
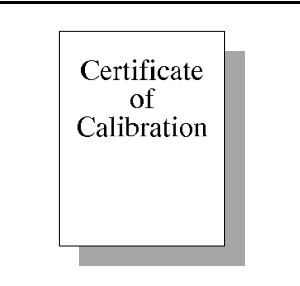
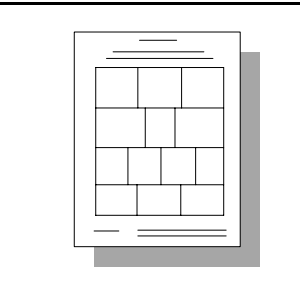
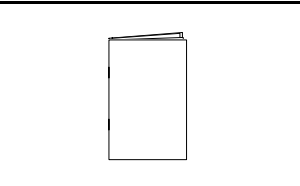
**Table 1: P7350 features and standard accessories (Cont.)**

Feature/Accessory	Description
	<p><b>Variable spacing adapter (4 ea).</b> The variable spacing adapter fits over the probe tip. Push the adapter onto the probe tip until it seats against the probe head.</p> <p>Use the variable spacing adapter to probe any two adjacent leads or test points spaced between 0.020 and 0.180-inches apart. See Figure 16 on page 28 for physical dimensions of the adapter. Adjust the articulated pins by gently rotating them using a pair of tweezers.</p> <p><b>NOTE:</b> The articulated pins can be bent, but they are fragile. Use extreme care when bending the pins.</p> <p>The elastomeric contacts inside the adapter are rated for 50-75 insertion cycles with the probe tip. Replace the adapter after exceeding these limits to avoid unreliable operation.</p> <p>Tektronix part number: 016-1885-XX (package of 4)</p>
	<p><b>Square pin adapter (4 ea).</b> Push the square pin adapter onto the probe tip until it seats against the probe head. Use the square pin adapter to connect the probe to other accessories, such as the Y-lead adapter or TwinFoot adapter. The inputs on the adapter are spaced 0.100 inches apart. See Figure 17 on page 28 for physical dimensions of the adapter.</p> <p><b>CAUTION:</b> To avoid damaging the square pin connectors, do not insert anything larger than a 0.025-inch square pin into the inputs.</p> <p>The elastomeric contacts inside the adapter are rated for 50-75 insertion cycles with the probe tip. Replace the adapter after exceeding these limits to avoid unreliable operation.</p> <p>Tektronix part number: 016-1884-XX (package of 4)</p>

**Table 1: P7350 features and standard accessories (Cont.)**

Feature/Accessory	Description
	<p><b>TwinFoot adapter (4 ea).</b> Use the TwinFoot adapter to probe two adjacent leads on a surface-mount integrated circuit. The TwinFoot adapter connects to the probe through the square pin adapter. Flexible fingers adapt to a range of lead spacings. See Figure 6 on page 13.</p> <p>Tektronix part number: 016-1785-XX (package of 4)</p>
	<p><b>Y-lead adapter (2 ea).</b> The Y-lead adapter connects to the probe through the square pin adapter. The socketed ends of the leads may be connected to the probe tips and accessories, or fitted onto 0.025-inch square pins.</p> <p>Tektronix part number: 196-3468-XX (package of 2)</p>
	<p><b>Antistatic wrist strap.</b> When using the probe, always work at an antistatic work station and wear the antistatic wrist strap.</p> <p>Tektronix part number: 006-3415-XX</p>
	<p><b>X-lead adapter (2 ea).</b> The X-lead adapter connects between accessories fitted with 0.025-inch pins, such as the SMT KlipChip and Micro KlipChip adapters.</p> <p>You can use the X-lead adapter with the adapters below to make connections between the probe tip and your circuit under test. Be aware of the electrical effects of the added lead length of the adapters, especially as circuit frequencies increase.</p> <p>Tektronix part number: 196-3473-XX (package of 2)</p>
	<p><b>SMT KlipChip adapter (2 ea).</b> Use this accessory to probe the leads on dual-in-line packages (DIP).</p> <p>Tektronix part number: 206-0364-XX</p>

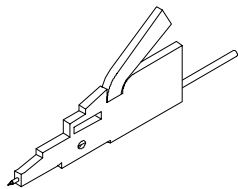
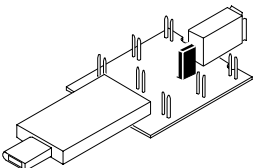
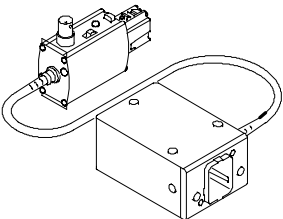
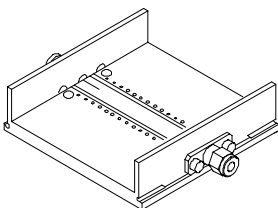
**Table 1: P7350 features and standard accessories (Cont.)**

Feature/Accessory	Description
	<p><b>Cable marker bands (10 ea).</b> Attach matching pairs of the marker bands onto the cable at the head and compensation box of each probe. The marker bands enable quick verification of which probe is connected to which instrument channel.</p> <p>Tektronix part number: 016-1886-XX (package of 10)</p>
	<p><b>Plastic accessory box.</b> Use the plastic box to store the probe accessories when not in use.</p> <p>Tektronix part number: 006-7164-XX</p>
	<p><b>Instrument case.</b> The instrument case protects the probe from harsh environments and provides room for storing optional accessories.</p> <p>Tektronix part number: 016-1879-XX</p>
	<p><b>Calibration certificate.</b> A certificate of traceable calibration is provided with every instrument shipped.</p>
	<p><b>Accessory reorder sheet.</b> Use the accessory reorder sheet as a quick guide for ordering accessories for your probe. The sheet provides photos and part numbers for identifying your accessories.</p> <p>Tektronix part number: 001-1362-XX</p>
	<p><b>Instruction Manual.</b> Provides instructions for operating and maintaining the P7350 differential probe</p> <p>Tektronix part number: 071-1238-XX</p>

## Optional Accessories

Table 2 shows the optional accessories that you can order for the P7350 differential probe.

**Table 2: Optional accessories**

Accessory	Description
	<p><b>Micro KlipChip adapters.</b> Use the adapters to probe the leads on integrated circuits that are surface-mounted.</p> <p>Tektronix part number: SMK4 (package of 4)</p>
	<p><b>IEEE1394 Adapter.</b> The IEEE1394 Adapter allows you to probe signals on the bus, external to system enclosures, without disturbing system operation. The adapter maintains a balanced 55 <math>\Omega</math> signal path and can be used in both single-ended and differential modes.</p> <p>Tektronix part number: 679-5027-XX</p>
	<p><b>TekConnect interface calibration adapter.</b> The calibration adapter is required when a performance verification or adjustment is done on the probe. It provides connectors and test points for internal probe measurements.</p> <p>Tektronix part number: 067-0422-XX</p>
	<p><b>Probe calibration fixture.</b> Use the probe calibration fixture to perform some of the calibration procedures. The calibration fixture connects to signal sources used to test the probe characteristics.</p> <p>Tektronix part number: 067-0419-XX</p>



## Operating Basics

This section discusses operating considerations and probing techniques. For more detailed information about differential measurements and common-mode rejection ratio (CMRR), see the *Reference* section on page 17.

The P7350 probe design is optimized for high bandwidth, low capacitance applications; it is not a general purpose probe. The probe head and tips are miniaturized for electrical characteristics and access to dense circuitry, and must be handled carefully. Rough or careless use will likely damage the probe.

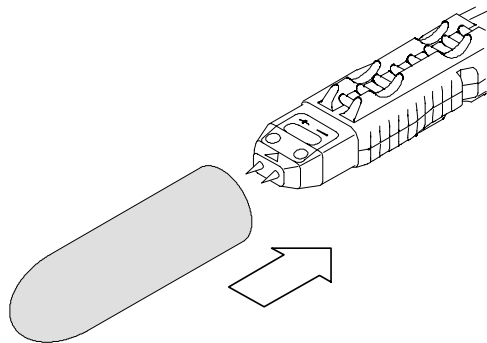
To avoid damaging the probe tips, minimize your lateral pressure on the tips. Always probe as straight onto the circuit (perpendicular) as possible. The probe tips are extremely sharp to ensure good contact and measurement integrity.



---

**WARNING.** *The sharp probe tips pose a skin penetration hazard. Use care when handling the probe. To prevent injury and/or probe damage, install the protective cover over the probe tips when the probe is not in use (see Figure 4).*

---



**Figure 4: Protect the probe tips with the protective cover**



## Input Voltage Limits

The P7350 differential probe is designed to probe low-voltage circuits. Before probing a voltage, take into account the limits for maximum input voltage, the common-mode signal range, and the differential-mode signal range. For specific limits, see *Specifications* on page 21.

### Maximum Input Voltage

The maximum input voltage is the maximum voltage to ground that the inputs can withstand without damaging the probe input circuitry.



**CAUTION.** To avoid damaging the inputs of the P7350 differential probe, do not apply more than  $\pm 15$  V (DC + peak AC) between each input and ground.

---

### Common-Mode Signal Range

The common-mode signal range is the maximum voltage that you can apply to each input, with respect to earth ground, without saturating the input circuitry of the probe. A common-mode voltage that exceeds the common-mode signal range may produce an erroneous output waveform even when the differential-mode specification is met. For *Specifications*, refer to page 21.

### Differential-Mode Signal Range

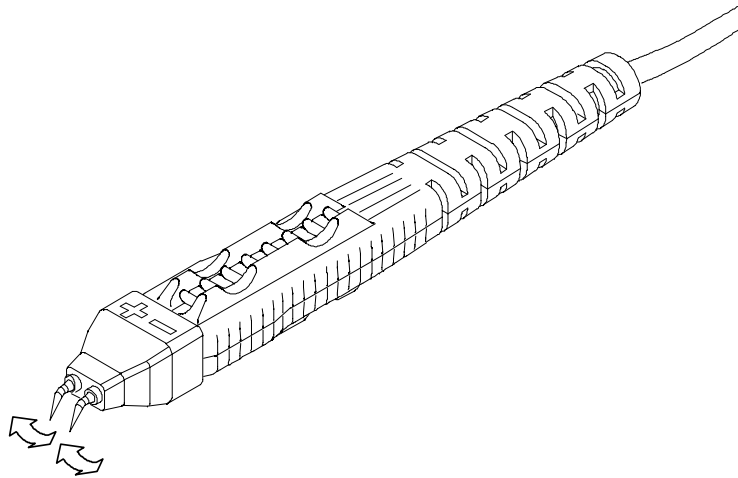
The differential-mode signal range is the maximum voltage difference between the plus and minus inputs that the probe can accept without distorting the signal. The distortion from a voltage that is too large can result in a clipped or otherwise distorted and inaccurate measurement. For *Specifications*, refer to page 21.

## Common-Mode Rejection

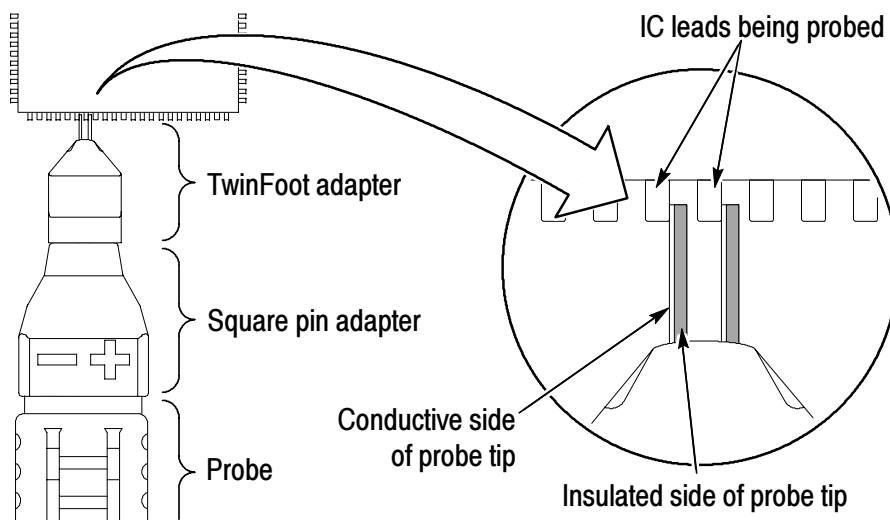
The common-mode rejection ratio (CMRR) is the ability of a probe to reject signals that are common to both inputs. More precisely, CMRR is the ratio of the differential gain to the common-mode gain. The higher the ratio, the greater the ability to reject common-mode signals. For additional information about CMRR, see page 18.

## Probing Techniques to Maximize CMRR

The common-mode rejection of the probe is highest when the probe is applied directly to the circuit, without using adapters. However, some probing tasks are made easier using accessories included with the probe. The accessories shown in Figures 5 and 6 achieve a high CMRR by minimizing the distance between the probe head and the signal source.



**Figure 5: Using the variable spacing adapter**

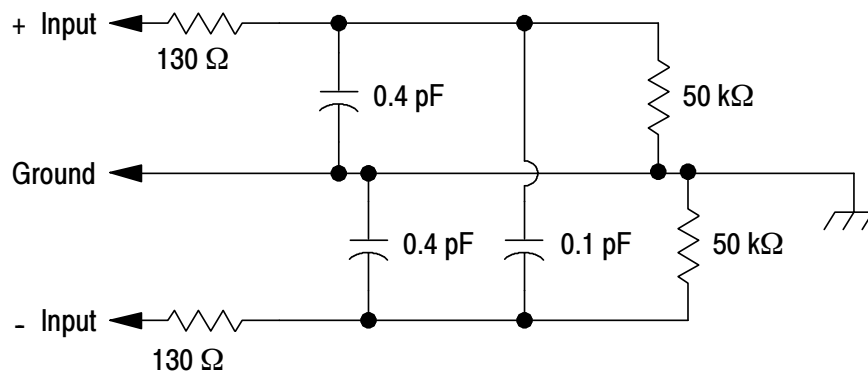


**Figure 6: Using the TwinFoot adapter**

## Input Impedance and Probe Loading

When you connect the probe inputs to a circuit, you are introducing a new resistance, capacitance, and inductance into the circuit. Each input of the P7350 differential probe has a characteristic input impedance of  $50\text{ k}\Omega$  to ground in parallel with less than  $0.4\text{ pF}$ . See Figure 7.

For signals with low source impedance and frequency, the  $50\text{ k}\Omega$  input impedance on each input is large enough to prevent the inputs from loading the signal sources. The greater the source impedances and the higher the signal frequencies, the more you must take these factors into account.



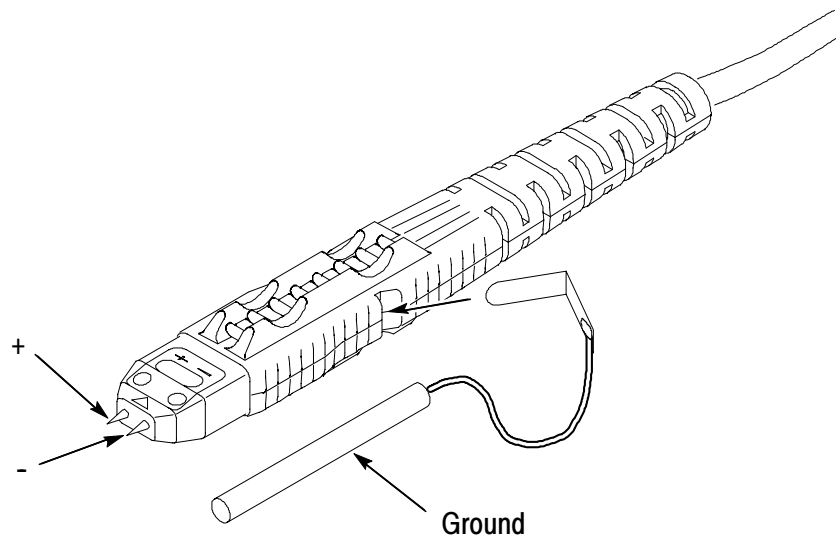
**Figure 7: Typical probe input model**

As the impedance of the signal source on an input increases, the more the probe loads the source and reduces the signal amplitude.

The frequency of the signal also affects signal measurement. As the frequency of the signal increases, the input impedance of the probe decreases. The lower the impedance of the probe relative to that of the source, the more the probe loads the circuit under test and reduces the signal amplitude. For a graph of frequency versus input impedance, refer to Figure 13 on page 25.

## Probe Grounding

In addition to the plus and minus inputs on the probe head, there is also a ground (common) input. The ground lead slides into the notch on the side of the probe. See Figure 8.



**Figure 8: Probe ground input**



**CAUTION.** To avoid damaging the circuitry under test, connect the probe ground (common), if used, to a ground-reference point only.

In most applications, the common-mode impedance to ground is greater than the differential impedance. Adding the probe ground lead does not improve the high-frequency performance of the measurement. You can use the probe to take a differential measurement regardless of whether or not the ground (common) is connected.

There are some applications that may require a ground reference connection to maintain measurement accuracy. Generally this is necessary when probing circuits which are fully isolated from ground, such as battery operated devices.

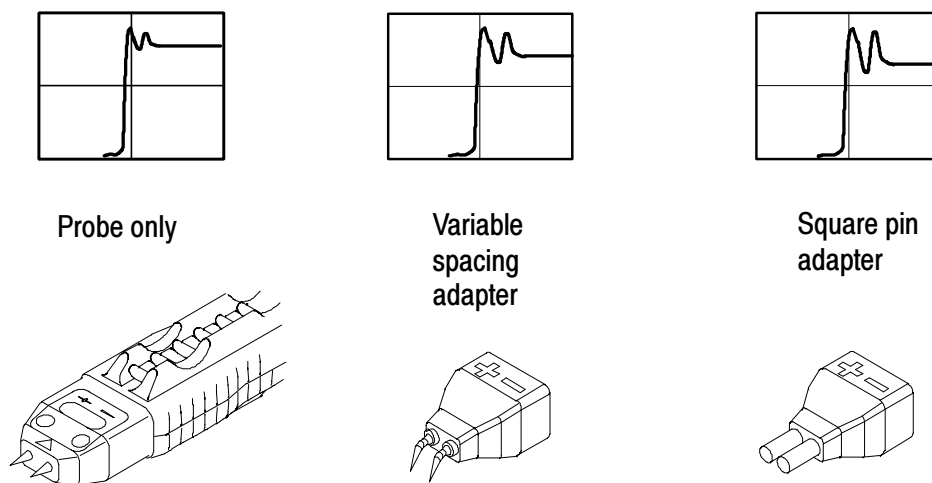
## Electrical Effects of Accessories

The probe tip accessories included with your probe help connect to different types of components. While these accessories make connections easier, be aware that the adapter you choose may affect the signal you are measuring, depending on a variety of factors, including signal frequency, source impedance, and lead length.

Use the probe only (without adapters) to optimize step and frequency response. Using the probe tip adapters adds inductance and capacitance, which increases step response and aberrations, and leads to increased ripples in frequency response. These effects increase as the source impedance and the measured waveform risetimes decrease. Refer to page 23 for input capacitance specifications when using the variable spacing and square pin adapters.

The recommended method for hands-free probing is to use the probe only (without adapters), with a probe positioner such as a Tektronix PPM100 or PPM203B. If you need a tip space between 0.020 and 0.180 inches apart, use the variable spacing adapter and the probe positioner. Use the square pin adapter for test points or component leads spaced farther than 0.180 inches apart.

Figure 9 illustrates the typical effects on a given signal using some of the adapters included with your probe.



**Figure 9: Typical effects on a signal using probe tip adapters**

# Reference

This section contains important reference information about differential measurements and how to increase the accuracy of your measurements.

## Problems with Single-Ended Measurements

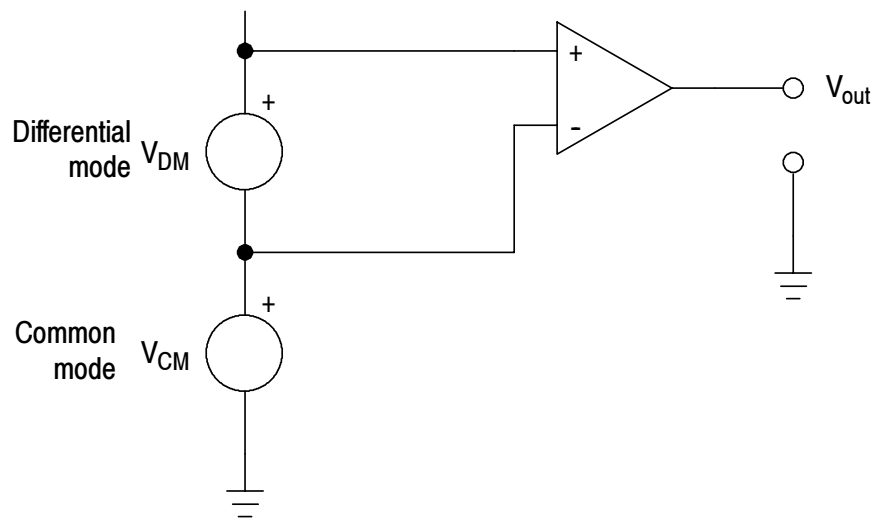
While suitable in many applications, single-ended measurements can present problems in the following situations:

- When the signal is not referenced to earth ground
- When the signal being measured is distorted or changed by connecting or disconnecting the probe ground reference lead

## Differential Measurements

Devices designed to make differential measurements avoid the problems posed by single-ended systems. These devices include a variety of differential probes, differential amplifiers, and isolators.

The differential amplifier (Figure 10 on page 18) is at the heart of any device or system designed to make differential measurements. Ideally, the differential amplifier rejects any voltage that is common to the inputs and amplifies any difference between the inputs. Voltage that is common to both inputs is often referred to as the Common-Mode Voltage ( $V_{CM}$ ) and voltage that is different as the Differential-Mode Voltage ( $V_{DM}$ ).



**Figure 10: Simplified model of a differential amplifier**

### Common-Mode Rejection Ratio

In reality, differential amplifiers cannot reject all of the common-mode signal. The ability of a differential amplifier to reject the common-mode signal is expressed as the Common-Mode Rejection Ratio (CMRR). The CMRR is the differential-mode gain ( $A_{DM}$ ) divided by the common-mode gain ( $A_{CM}$ ). It is expressed either as a ratio or in dB.

$$CMRR = \frac{A_{DM}}{A_{CM}} \quad dB = 20 \log \frac{A_{DM}}{A_{CM}}$$

CMRR generally is highest (best) at DC and degrades with increasing frequency.

### Assessing CMRR Error

Figure 12 on page 24 shows the CMRR of the P7350 differential probe. This derating chart assumes a common-mode signal that is sinusoidal.

A quick way to assess the magnitude of CMRR error when the common-mode signal is not sinusoidal is to connect both leads to the same point in the circuit. The oscilloscope will display only the common-mode component which is not fully rejected by the probe. While this technique may not give you entirely accurate measurements, it does allow you to determine if the magnitude of the common-mode error signal is significant.

### **Input Impedance Effects on CMRR**

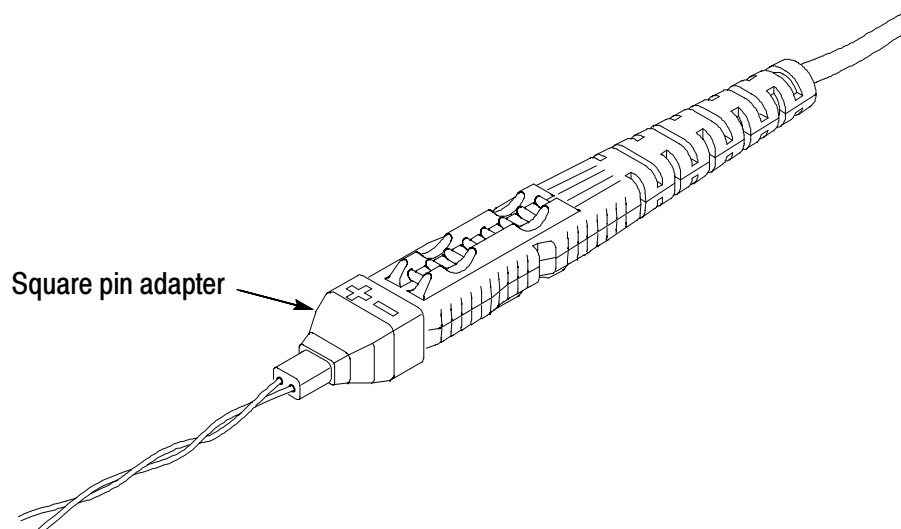
The lower the input impedance of the probe relative to the source impedance, the lower the CMRR. See Figure 12 on page 24. Significant differences in the source impedance driving the two inputs will also lower the CMRR.

## **Extending the Input Leads**

At times it may be necessary to extend the probe inputs with wires or a probe tip adapter. When you do this, you should minimize the lead lengths to optimize common-mode rejection and twist the input leads together as shown in Figure 11 on page 20.

Twisting the input leads together does increase capacitance that may degrade high-frequency performance. You should take into account any effects caused by the extended leads when you take a measurement.





**Figure 11: Twisting the input leads**

## **Extending the Ground Lead**

Extending the ground lead will have little, if any, affect on your measurements. In most circuits, the ground path from the differential source has sufficiently high impedance to damp out any ringing caused by lead inductance.

# Appendix A: Specifications

The specifications in Tables 3 through 5 apply to a P7350 probe installed on a TDS6604 oscilloscope. The probe must have a warm-up period of at least 20 minutes and be in an environment that does not exceed the limits described in Table 3. Specifications for the P7350 differential probe fall into three categories: warranted, typical, and nominal characteristics.

## Warranted Characteristics

Warranted characteristics (Table 3) describe guaranteed performance within tolerance limits or certain type-tested requirements.

Warranted characteristics that have checks in the *Performance Verification* section are marked with the ✓ symbol.

**Table 3: Warranted electrical characteristics**

Characteristic	Description
✓ Rise time (probe only)	100 ps, +20 °C to +30 °C (+68 °F to +86 °F), 250 mV step
✓ DC gain	0.16 ±2% (corresponds to 6.25 X attenuation)
✓ Output offset voltage	±10 mV +20 °C to +30 °C (+68 °F to +86 °F)
Maximum nondestructive input voltage	±15 V(DC + peak AC) between signal and common of the same channel.
Delay variation (probe-to-probe)	600 ps maximum
Temperature	Operating: 0 to +40 °C (+32 to +104 °F) Nonoperating: -55 to +75 °C (-131 to +167 °F) <sup>1</sup>

**Table 3: Warranted electrical characteristics (Cont.)**

Characteristic	Description
Humidity	Operating: 0-90% RH, tested at +30 to + 40 °C (+68 to +104 °F)  Nonoperating: 0-90% RH, tested at +30 to + 60 °C (+68 to +140 °F)

<sup>1</sup> See warning that follows.



**WARNING.** To avoid a burn hazard at high ambient temperatures, do not touch the probe with bare hands at nonoperating temperatures above + 70 °C. Allow sufficient time for the probe to cool before handling.

## Typical Characteristics

Typical characteristics (Tables 4 and 6) describe typical but not guaranteed performance.

**Table 4: Typical electrical characteristics**

Characteristic	Description
Bandwidth (probe only)	DC to 5 GHz (-3dB)
Rise time (probe only), 20-80%	65 ps, +20 °C to +30 °C (+68 °F to +86 °F), 250 mV step
Differential signal range	±2.5 V
Differential offset range	±1.25 V
Linearity	±1% or less of dynamic range
Common-mode signal range	+6.25 V to -5.0 V

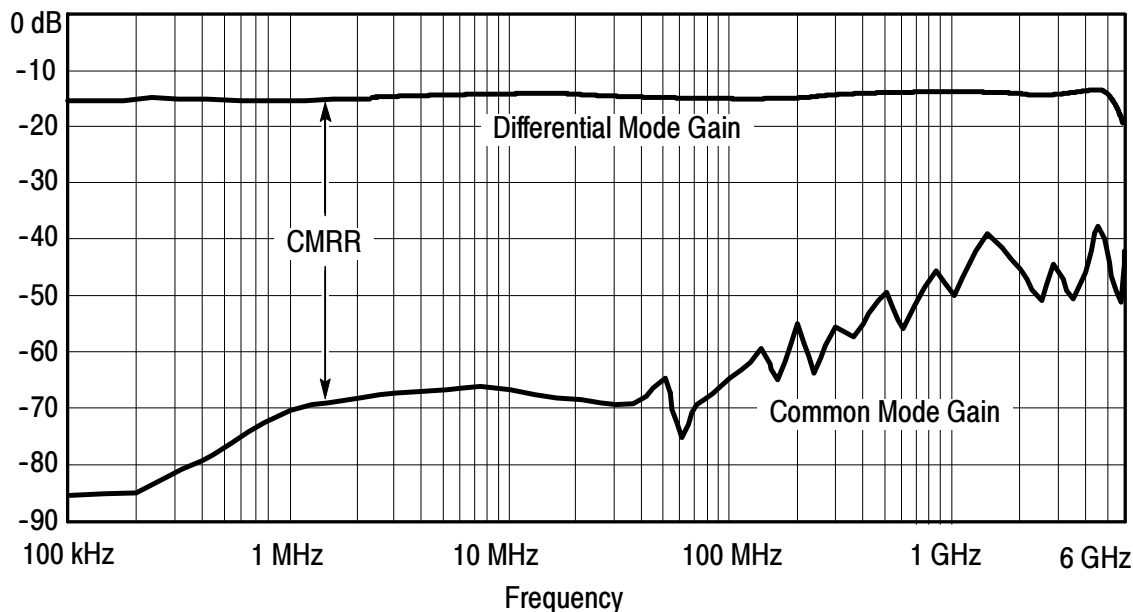
**Table 4: Typical electrical characteristics (Cont.)**

<b>Characteristic</b>	<b>Description</b>
Common-mode rejection ratio	$\geq 60$ dB at DC $\geq 55$ dB at 1 MHz $\geq 50$ dB at 30 MHz $\geq 30$ dB at 1 GHz
Delay time	5.69 ns
Differential input resistance, DC coupled	100 k $\Omega$ $\pm 2\%$
Differential input capacitance:	
probe only	<0.3 pF at 100 MHz
probe with variable spacing adapter (Tektronix part number 016-1885-00)	<0.45 pF at 100 MHz
probe with square pin adapter (Tektronix part number 016-1884-00)	<0.55 pF at 100 MHz
Common-mode input resistance, DC coupled	50 k $\Omega$ $\pm 2\%$ (per side)
Common-mode input capacitance	<0.45 pF at 100 MHz (per side)
Input impedance	See Figure 13
Noise, referred to input	46 nV/ $\sqrt{\text{Hz}}$ @100 MHz
DC Offset Scale Accuracy (gain of offset signal path)	$\pm 2.0\%$
DC Offset Drift	150 $\mu\text{V}/^\circ\text{C}$ or less at output of probe  0.94 mV/ $^\circ\text{C}$ or less displayed on screen with TekConnect interface

**Table 4: Typical electrical characteristics (Cont.)**

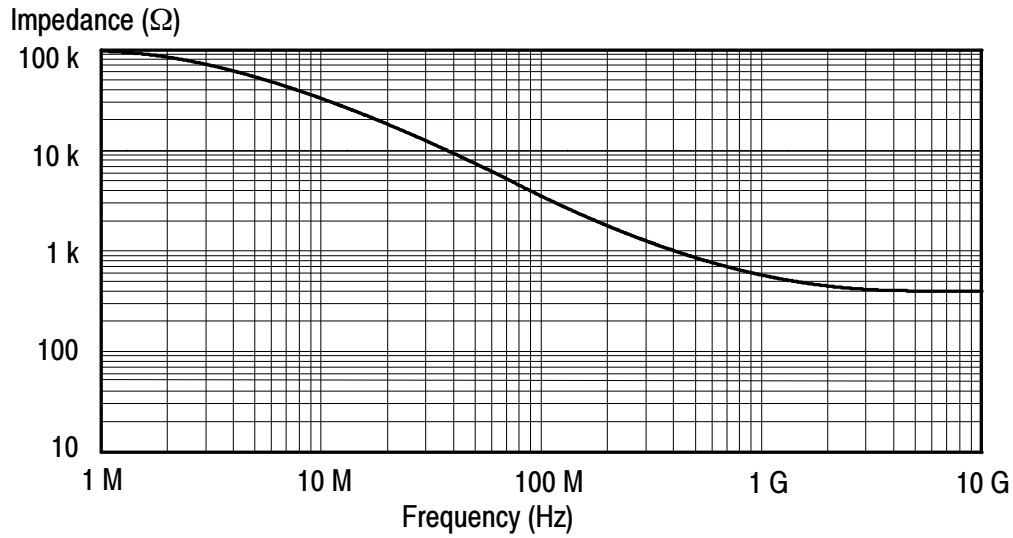
Characteristic	Description
DC Voltage Measurement Accuracy (referred to input)	$\pm[(2\% \text{ of input relative to offset}) + (2\% \text{ of offset}) + 62.5 \text{ mV} + 50.0 \text{ mV}]$ gain error = $\pm 2\%$ of input voltage relative to offset offset gain error = $\pm 2\%$ of effective offset at probe tip output zero = $\pm 62.5 \text{ mV}$ effective at probe tip linearity error = $\pm 1.0\%$ of 5.0 V dynamic range (50.0 mV)

Figure 12 shows the typical common-mode and differential gain of the probe. The CMRR can be found by subtracting the common-mode gain from the differential gain. For example, -80 dB CM gain equals approximately +64 dB CMRR.

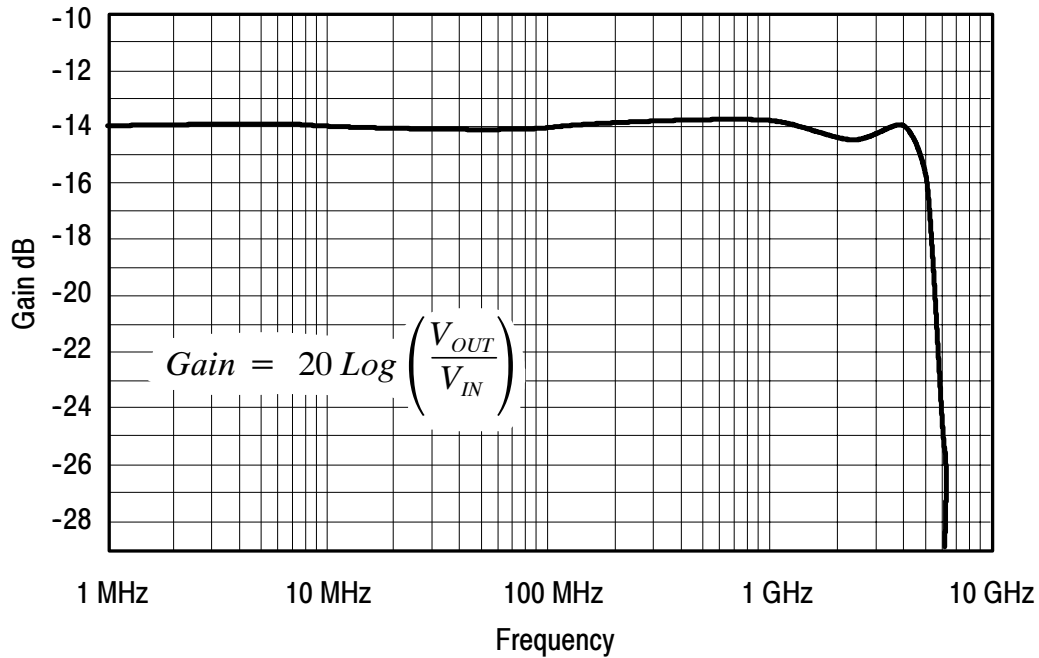


**Figure 12: Typical common- and differential-mode gain plots**

The graph in Figure 13 represents simulation results of a first order model of the probe input.



**Figure 13: Typical differential input impedance vs frequency**



**Figure 14: Typical bandwidth**

## Nominal Characteristics

Nominal characteristics (Table 5) describe guaranteed traits, but the traits do not have tolerance limits.

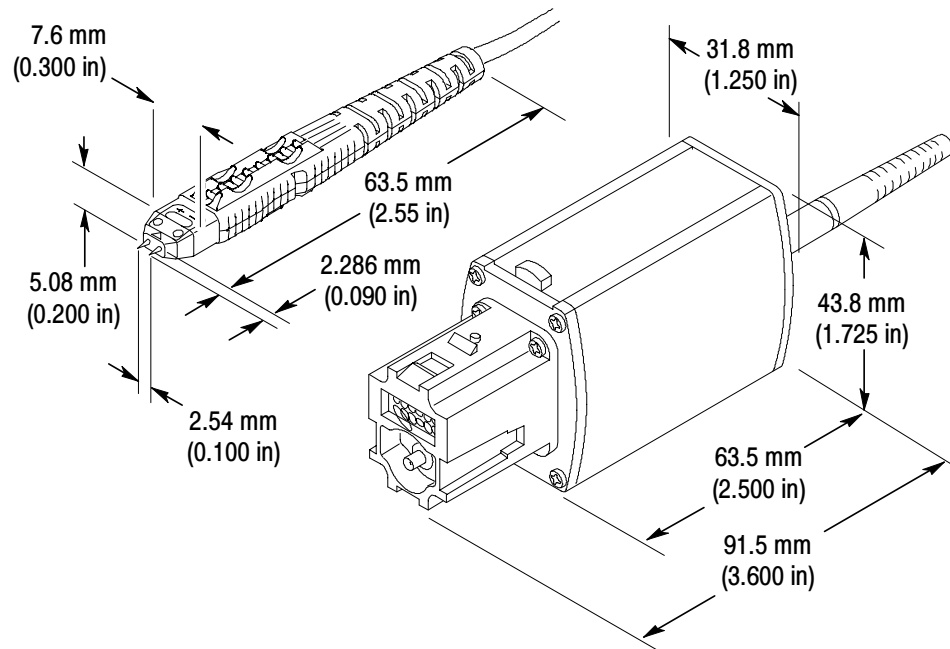
**Table 5: Nominal electrical characteristics**

Input configuration	Differential (two inputs, + and - ), with case ground
Attenuation	6.25 X <sup>1</sup>
Input coupling	DC
Termination	Terminate output into 50 $\Omega$

<sup>1</sup> **All TekConnect host instruments recognize this gain setting and adjust the Volts/Div setting to correspond to a normal 1-2-5 sequence of gains.**

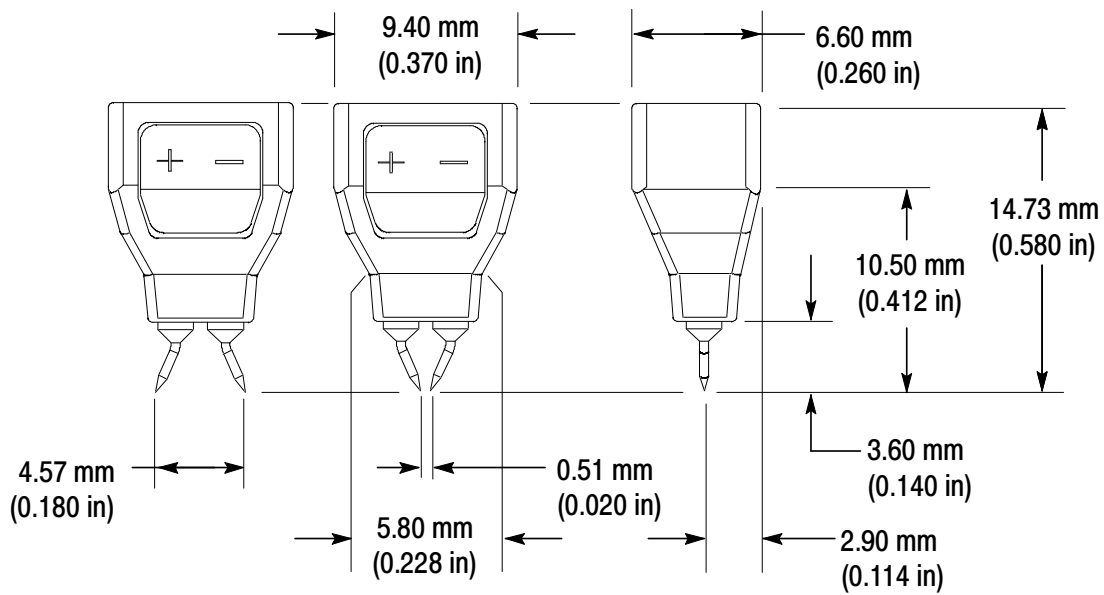
**Table 6: Typical mechanical characteristics**

Dimensions, control box	91.5 mm × 43.8 mm × 31.8 mm (3.60 in × 1.725 in × 1.25 in)
Dimensions, probe head	59 mm × 7.7 mm × 5.1 mm (2.30 in × 0.30 in × 0.20 in)
Dimensions, output cable	1.2 m (47 in)
Unit weight (probe only)	223 g (7.5 oz)

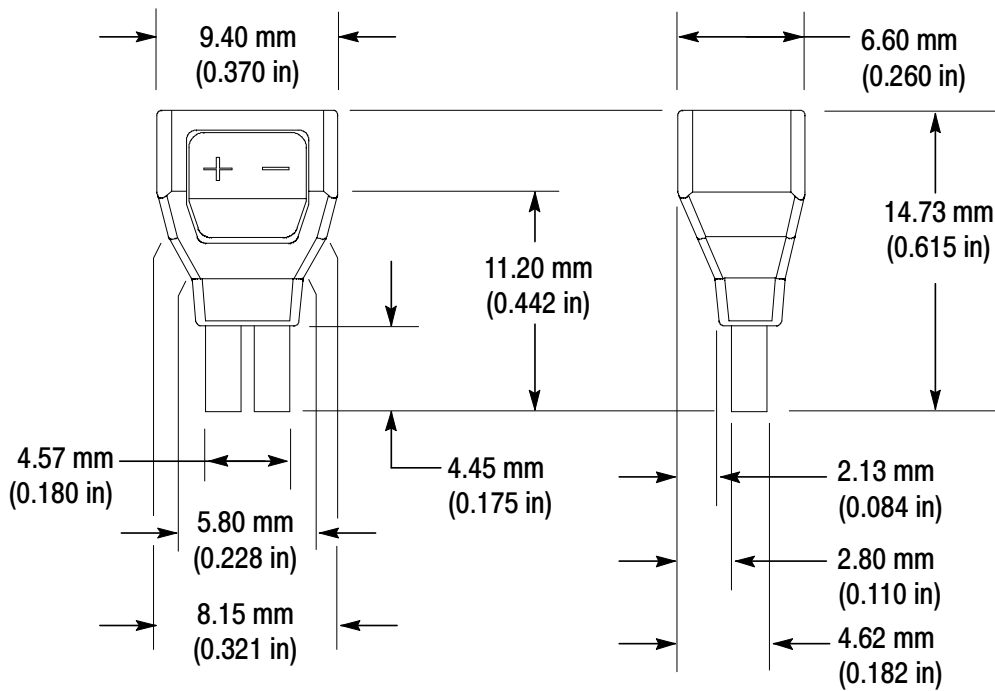


**Figure 15: Probe head and compensation box dimensions**





**Figure 16: Variable spacing adapter dimensions**



**Figure 17: Square pin adapter dimensions**

## Appendix B: Performance Verification

Use the following procedures to verify specifications of the probe. Before beginning these procedures, refer to page 42 and photocopy the test record, and use it to record the performance test results. The recommended calibration interval is one year.

These procedures test the following specifications:

- Output offset voltage
- DC gain accuracy
- Rise time

### Equipment Required

Refer to Table 7 for a list of the equipment required to verify the performance of your probe.

**Table 7: Equipment required for performance verification**

Item description	Performance requirement	Recommended example <sup>1</sup>
Sampling Oscilloscope	20 GHz bandwidth	Tektronix TDS8000
Sampling module (head), with extension cable	20 GHz bandwidth	Tektronix 80E04 with 012-1568-00 cable
Oscilloscope	TekConnect interface	Tektronix TDS7404
Calibration Step Generator		067-1338-0X
Probe Positioner		Tektronix PPM203B
Dual Power Supply	5.0 VDC at 1 mA	Tektronix PS280
DMM (2), with leads	0.1 mV resolution	Fluke 87 or equivalent
Feedthrough Termination	BNC, 50 $\Omega$ $\pm$ 0.05 $\Omega$	011-0129-00
Coaxial cable	Male-to-Male SMA	012-0649-00

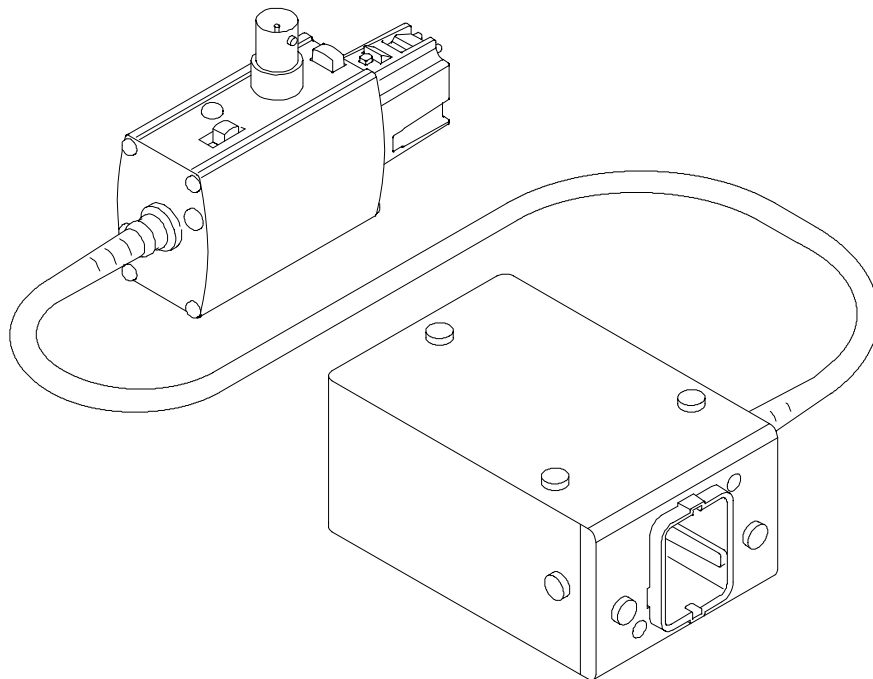
**Table 7: Equipment required for performance verification (Cont.)**

<b>Item description</b>	<b>Performance requirement</b>	<b>Recommended example<sup>1</sup></b>
Coaxial cable	Male-to-Male BNC, 50 $\Omega$	012-0057-01
Test leads (3)	Banana plug ends, red	012-0031-00
Test leads (3)	Banana plug ends, black	012-0039-00
Probe Calibration Fixture	See page 33	067-0419-00
TekConnect Interface Calibration Adapter	See page 31	067-0422-00
Adapter	TekConnect-to-SMA	TCA-SMA
Adapter	SMA Male-to-Male	015-1011-00
Adapter	SMA Male-to-BNC Female	015-1018-00
Adapter	BNC Female-to-Dual Banana	103-0090-00
Adapter	Square pin adapter	016-1884-00
Adapter	Y-lead adapter	196-3468-00
Adapters (2)	KlipChip adapter	206-0364-00
SMA torque wrench	5/16-inch, 7 in-lb.	

<sup>1</sup> **Nine-digit part numbers (XXX-XXXX-XX) are Tektronix part numbers.**

## TekConnect Interface Calibration Adapter

To complete the performance verification and adjustment procedures for your probe, you need to order the optional TekConnect Interface Calibration Adapter, Tektronix part number 067-0422-00 (see Figure 18). The adapter connects between the host instrument and the probe under test and provides connectors for internal probe measurements.

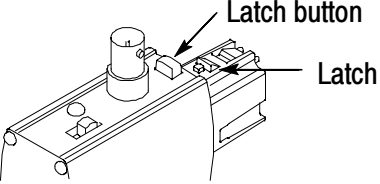
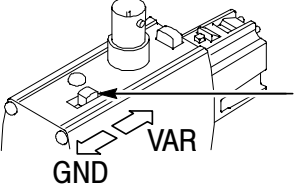
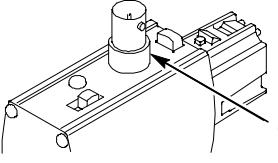
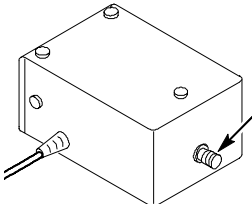


**Figure 18: TekConnect Interface Calibration Adapter**

When the adapter is connected to the oscilloscope, the adapter is identified as a valid calibration device. However, additional power supplies necessary to power the probe are not enabled until a TekConnect probe is connected to the adapter and identified by the oscilloscope. When a probe is detected through the adapter, the Volts/div readout on the oscilloscope displays ##.

Refer to Table 8 on page 32 for detailed features of the calibration adapter.

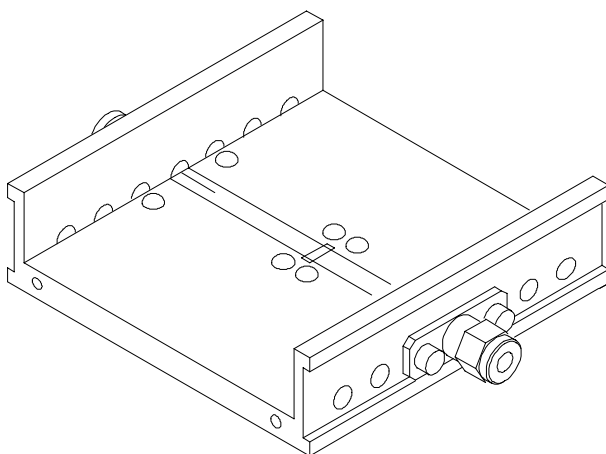
**Table 8: TekConnect Interface Calibration Adapter features**

Feature	Description
 <p>Latch button Latch</p>	<p><b>Latch button.</b> The spring-loaded latch mechanically retains the adapter to the oscilloscope. To release the adapter, grasp the adapter housing, depress the latch button, and pull the adapter straight out of the oscilloscope.</p>
 <p>Offset GND/Variable VAR GND</p>	<p><b>Offset output select switch.</b> The offset output switch selects between ground and the offset voltage level from the oscilloscope.</p> <p>Leave the switch in the ground position for the performance verification procedures. The variable position is only used in the adjustment procedures.</p>
 <p>Offset voltage output</p>	<p><b>Offset voltage.</b> The offset voltage of the probe is accessed through the BNC connector.</p> <p>Measure the offset voltage using a DVM, BNC coaxial cable and BNC-to-dual-banana jack.</p>
 <p>Signal out</p>	<p><b>Signal out.</b> The SMA connector on the rear of the box allows for direct monitoring of the probe signal.</p>

## Probe Calibration Fixture

Some of the procedures in this manual use a probe calibration fixture, Tektronix part number 067-0419-00.

The calibration fixture provides a means to test the probe for both common mode and differential mode measurements. SMA connectors allow stimulus signals to connect to the fixture and are located on the front and back of the fixture. The fixture is designed to be used with a probe positioner, such as a Tektronix PPM203B.

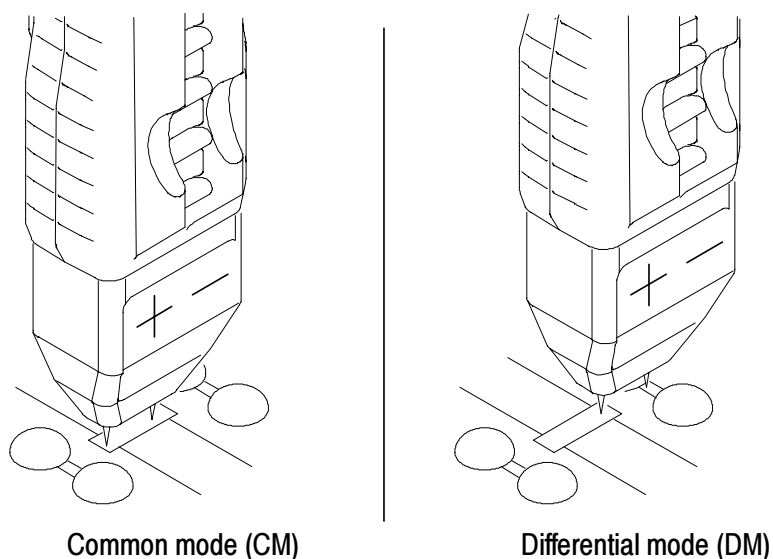


**Figure 19: Probe Calibration Fixture**

### Using the Probe Calibration Fixture

1. Connect the fixture to the test circuit using an SMA cable.
2. Connect the 50  $\Omega$  termination included with the fixture to the unused SMA connector.
3. Insert and secure the probe in a probe positioner.
4. Position the probe over the fixture, using either the positioner coarse adjustment or otherwise manipulating the positioner arm in place.

- Using the fine position and/or pressure adjust, maneuver the probe so that the pins contact the CM or DM test points, depending on which test you are performing. (See Figure 20.)



**Figure 20: Probe Calibration Fixture test points**

- Verify that contact is made on both pins. (You may need to readjust the fine position and/or pressure adjustment to make positive contact with the test points.)
- Proceed with the specific test instructions.

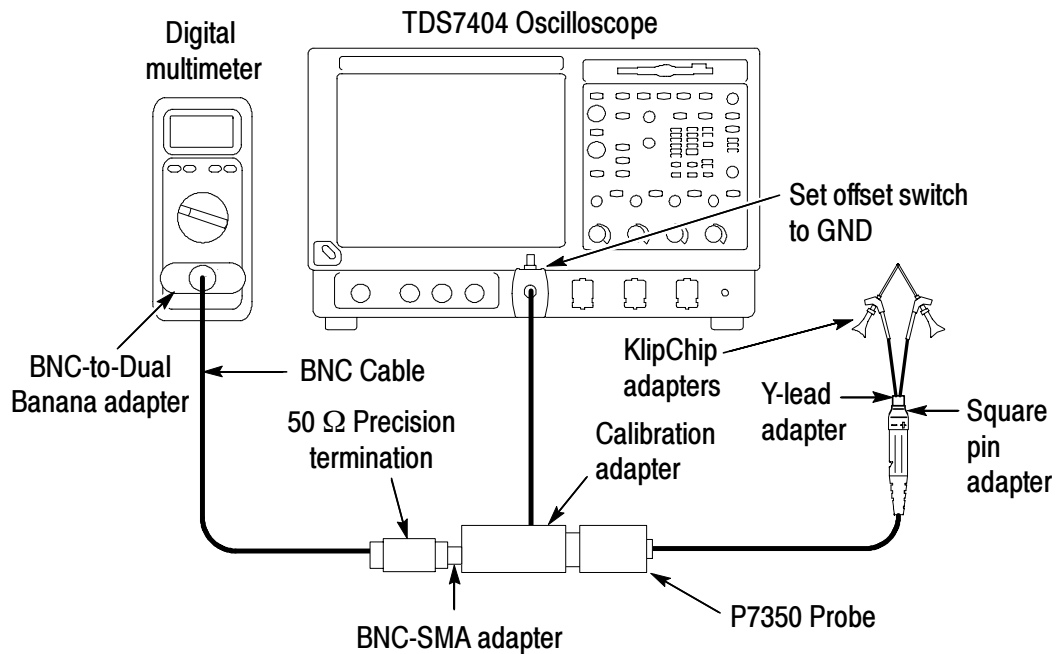
## Equipment Setup

Use this procedure to set up the equipment to test the probe.

- Connect the probe calibration adapter to the oscilloscope.
- Connect the probe to the probe calibration adapter.
- Turn on the oscilloscope and enable the channel.
- Allow 30 minutes for the equipment to warm up.

## Output Offset Voltage

1. Connect the equipment as shown in Figure 21.



**Figure 21: Setup for the output offset voltage test**

2. Set the offset switch on the calibration adapter to **GND**.

---

**NOTE.** Leave the offset switch in the ground position for all of the performance verification checks.

---

3. Set the multimeter to read DC volts.
4. Verify that the output voltage is 0 V,  $\pm 10$  mV.
5. Record the results on the test record.



## DC Gain Accuracy

1. Connect the probe input to the power supplies as shown in Figure 22. Monitor the source voltage with one of the DMMs.
2. Set the voltage on each power supply to approximately +0.25 V (+0.5 V total). Record this source voltage as  $V_{in1}$ .

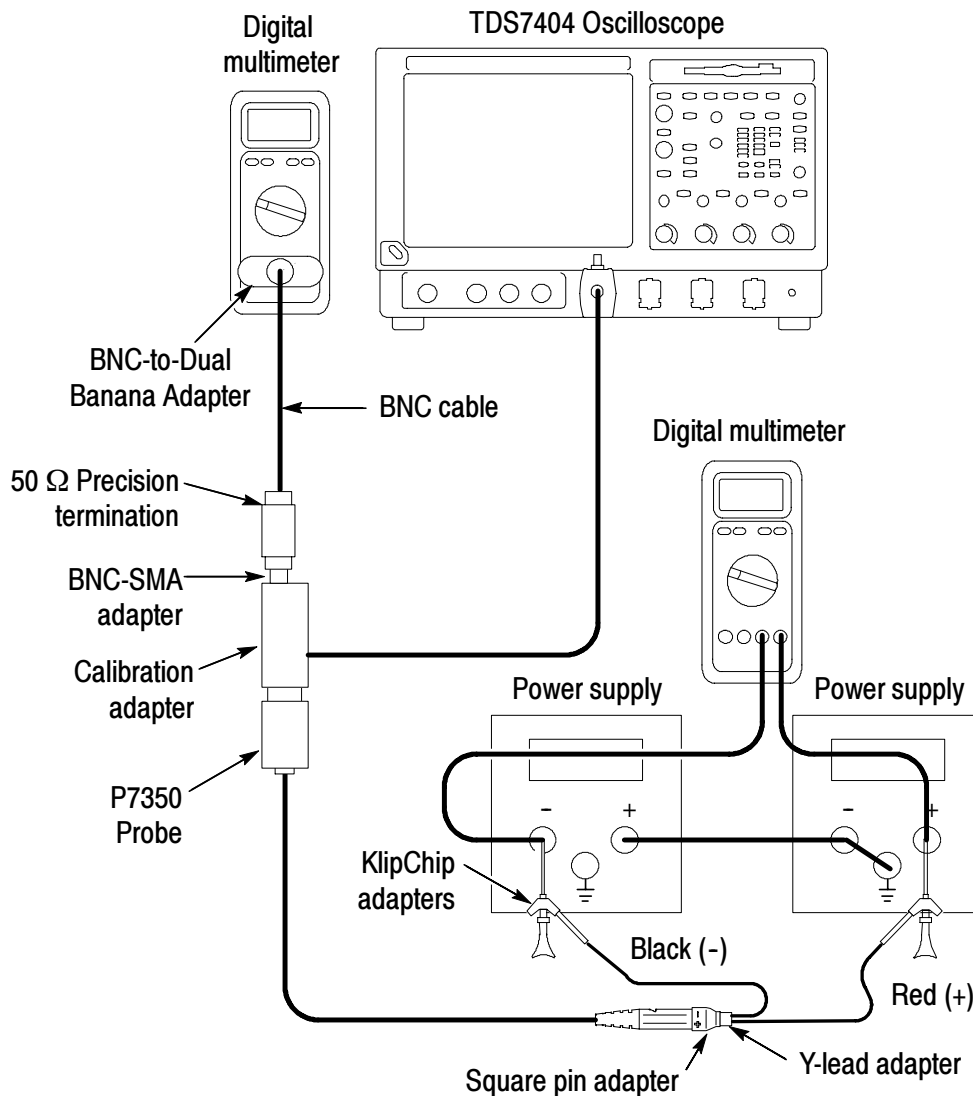


Figure 22: DC Gain Accuracy setup

3. Record the output voltage (on the second DMM) as  $V_{out1}$ .
4. Disconnect and reverse the red and black leads from the probe to the power supplies. Record the actual voltage as  $V_{in2}$ .
5. Record the output voltage (on the second DMM) as  $V_{out2}$ .
6. Calculate the gain as follows:  $(V_{out1} - V_{out2}) \div (V_{in1} - V_{in2})$ .
7. Verify that the gain is 0.16,  $\pm 2\%$ .
8. Record the calculated gain on the test record.

## Rise Time

This procedure verifies that the probe meets rise time specifications. Two rise times are measured; the test system, and the test system with the probe included. The probe rise time is calculated using the two measurements.

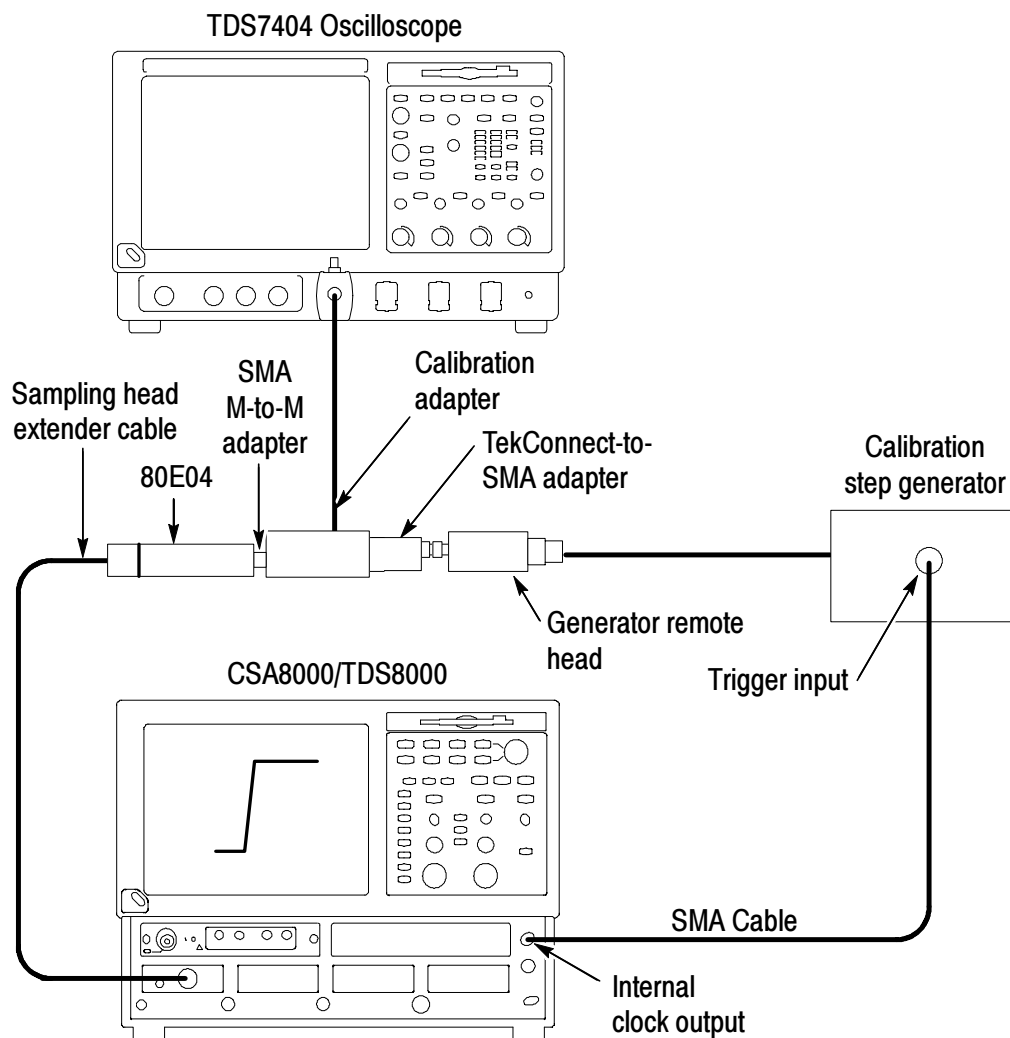
1. Connect the test equipment as shown in Figure 23 on page 38.



---

**CAUTION.** Use care when working with SMA connectors: support equipment to avoid mechanical strain on the connectors, and use a torque wrench to tighten connections to 7 in-lbs.

---



**Figure 23: Test system rise time setup**

2. Set the CSA/TDS8000 oscilloscope trigger to internal clock.

---

**NOTE.** The CSA/TDS8000 oscilloscope is used for taking the measurements in these procedures. All references to oscilloscope adjustments refer to the CSA/TDS8000. The TDS7404 oscilloscope is only used to power the probe.

---

3. Select the channel you have connected to on the 80E04 sampling head, and then set the oscilloscope vertical scale to 50 mV/div.

---

**NOTE.** *The output of the step generator rises from a -250 mV level to ground.*

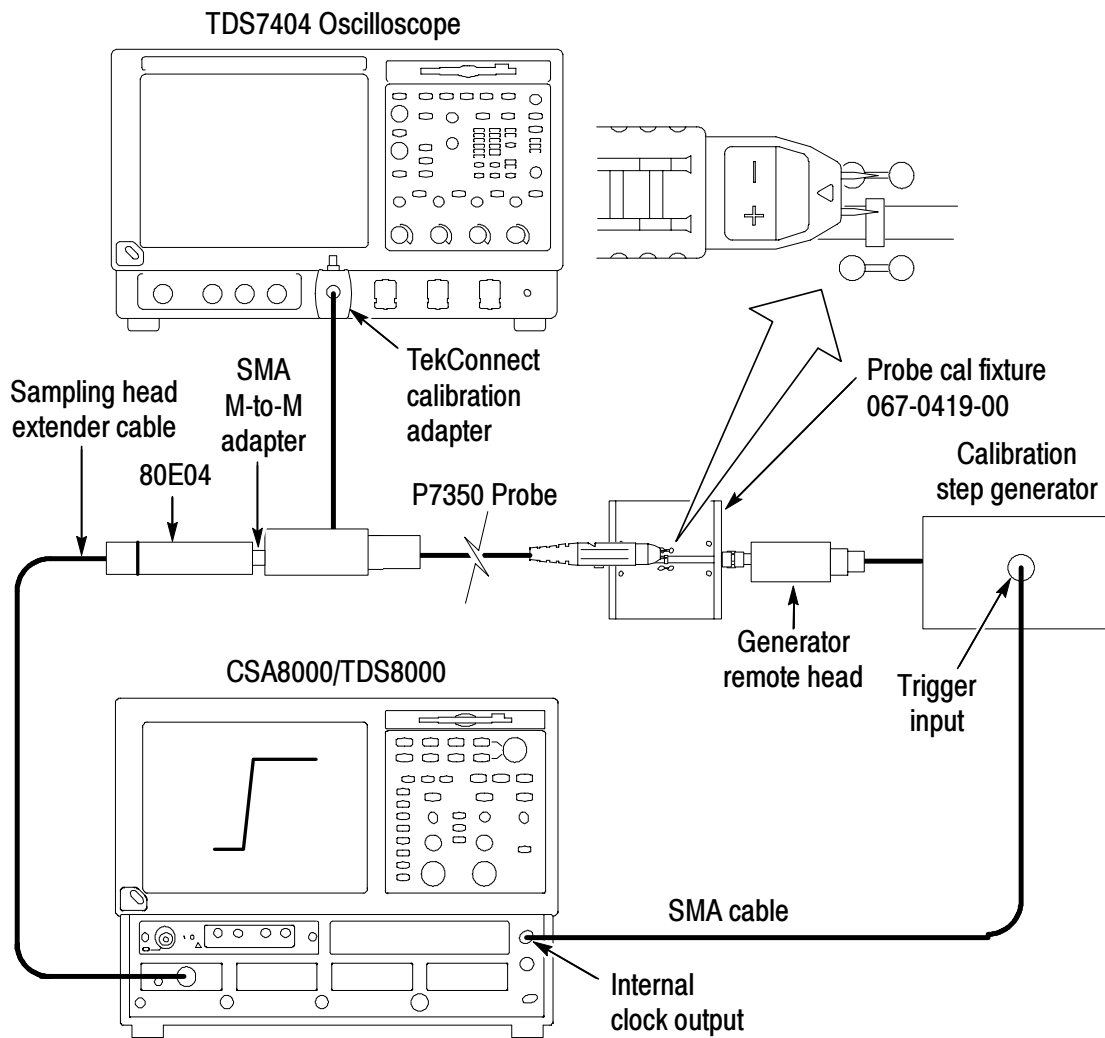
---

4. Adjust the oscilloscope horizontal and vertical position controls to display a signal similar to that shown in Figure 23.
5. Set the oscilloscope horizontal scale to 50 ps/div and center the waveform.
6. Use the oscilloscope measurement capability to display rise time. Increase the stability of the pulse edge measurement by using averaging, if available. Rise time is determined from the 10% and 90% amplitude points on the waveform. Record the rise time as  $t_s$ .

The following steps instruct you to assemble the test setup that includes the probe, as shown in Figure 24. The system and probe rise time ( $t_{s+p}$ ) that you measure in step 17 is used to calculate the probe rise time ( $t_p$ ) in step 18.

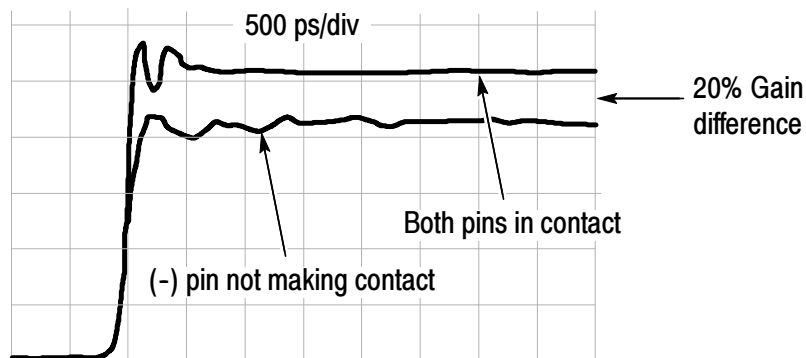
7. Set the step generator control switch to standby.
8. Remove the TekConnect-SMA adapter from the test setup.
9. Connect the probe to the TekConnect calibration adapter.
10. Connect the probe cal fixture to the step generator remote head, and the termination to the other input of the probe cal fixture.
11. Secure the probe head in the probe positioner.

The test setup should now be connected as shown in Figure 24 on page 40.



**Figure 24: Test system rise time setup with probe**

12. Set the step generator control switch to on.
13. On the TDS8000, expand the horizontal scale to help locate the step edge in step 14, then adjust horizontal range to 500 ps/div while maintaining the edge view. For a more stable measurement display, turn averaging on.
14. Using the probe positioner, probe the DM test points on the probe calibration fixture. Compare your display to Figure 25 on page 41 to verify that you have a valid connection with both pins.



**Figure 25: Verifying both probe pins are contacting the DM test points**

15. Adjust the oscilloscope vertical scale to 10 mV/div, averaging on.
16. Adjust the oscilloscope horizontal positioning to place the rising edge of the signal so that it crosses the second vertical and center horizontal graticule lines.
17. Use the oscilloscope measurement capability to display rise time. Rise time is determined from the 10% and 90% amplitude points on the waveform. Record the rise time as  $t_{s+p}$ .
18. Calculate the probe rise time using the following formula:

$$t_p = \sqrt{t_{(s+p)}^2 - t_s^2}$$

19. Record the calculated probe rise time on the test record.

**Test record**

Probe Model: \_\_\_\_\_

Serial Number: \_\_\_\_\_

Certificate Number: \_\_\_\_\_

Temperature: \_\_\_\_\_

RH %: \_\_\_\_\_

Date of Calibration: \_\_\_\_\_

Technician: \_\_\_\_\_

Performance test	Minimum	Incoming	Outgoing	Maximum
Output offset voltage	- 10 mV	_____	_____	+ 10 mV
DC gain accuracy	0.1568	_____	_____	0.1632
Rise time	N/A	_____	_____	100 ps

## Appendix C: Maintenance

This section details the maintenance for the P7350 differential probe.

### Inspection and Cleaning

Protect the probe from adverse weather conditions. The probe is not waterproof.



---

**CAUTION.** *To prevent damage to the probe, do not expose it to sprays, liquids, or solvents. Do not use chemical cleaning agents; they may damage the probe. Avoid using chemicals that contain benzene, benzene, toluene, xylene, acetone, or similar solvents.*

---

Clean the exterior surfaces of the probe with a dry, lint-free cloth or a soft-bristle brush. If dirt remains, use a soft cloth or swab dampened with a 75% isopropyl alcohol solution. A swab is useful for cleaning narrow spaces on the probe. Do not use abrasive compounds on any part of the probe.



---

**CAUTION.** *Avoid getting moisture inside the probe during exterior cleaning and use only enough solution to dampen the swab or cloth. Use a 75% isopropyl alcohol solution as a cleanser, and rinse with deionized water.*

---

### Replacement Parts

Refer to the *Replaceable Parts* section for a list of customer replacement parts. Due to the sophisticated design of the P7350 differential probe, there are no user replaceable parts within the probe.



## Preparation for Shipment

If the original packaging is unfit for use or not available, use the following packaging guidelines:

1. Use a corrugated cardboard shipping carton having inside dimensions at least one inch greater than the probe dimensions. The box should have a carton test strength of at least 200 pounds.
2. Put the probe into an antistatic bag or wrap to protect it from dampness.
3. Place the probe into the box and stabilize it with light packing material.
4. Seal the carton with shipping tape.

## Appendix D: Replaceable Parts

This section contains a list of replaceable parts for the P7350 differential probe. Use this list to identify and order replacement parts.

### Parts Ordering Information

Replacement parts are available from or through your local Tektronix, Inc. service center or representative.

Changes to Tektronix instruments are sometimes made to accommodate improved components as they become available and to give you the benefit of the latest circuit improvements. Therefore, when ordering parts, it is important to include the following information in your order:

- Part number
- Instrument type or model number
- Instrument serial number
- Instrument modification number, if applicable

If a part you order has been replaced with a different or improved part, your local Tektronix service center or representative will contact you concerning any change in the part number.

## Using the Replaceable Parts List

The tabular information in the Replaceable Parts List is arranged for quick retrieval. Understanding the structure and features of the list will help you find the information you need for ordering replacement parts.

### Item Names

In the Replaceable Parts List, an Item Name is separated from the description by a colon (:). Because of space limitations, an Item Name may sometimes appear as incomplete. For further Item Name identification, U.S. Federal Cataloging Handbook H6-1 can be used where possible.

### Indentation System

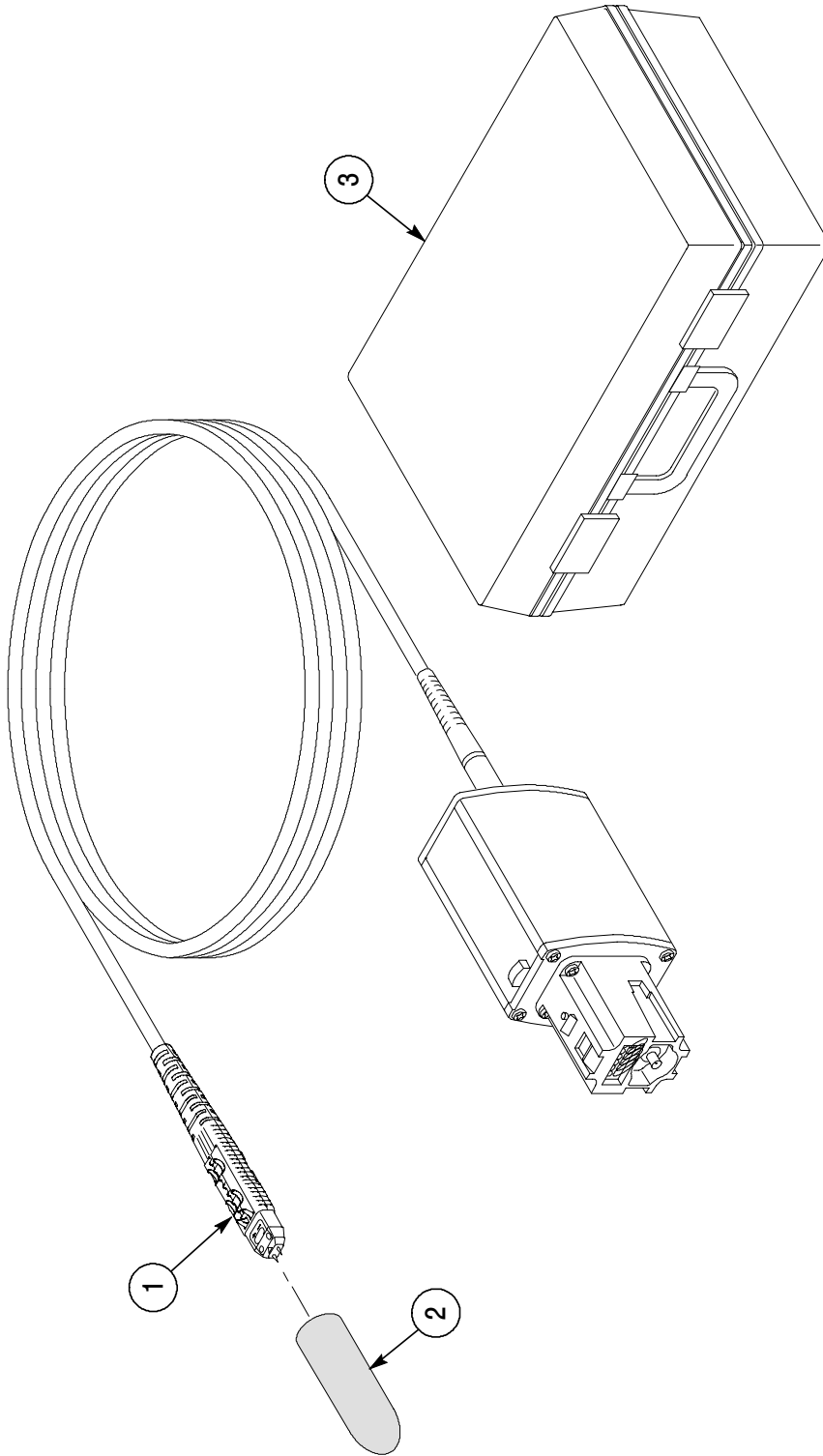
This parts list is indented to show the relationship between items. The following example is of the indentation system used in the Description column:

<i>1</i>	<i>2</i>	<i>3</i>	<i>4</i>	<i>5</i>	<i>Name &amp; Description</i>
					<i>Assembly and/or Component</i>
					<i>Attaching parts for Assembly and/or Component</i>
					<i>(END ATTACHING PARTS)</i>
					<i>Detail Part of Assembly and/or Component</i>
					<i>Attaching parts for Detail Part</i>
					<i>(END ATTACHING PARTS)</i>
					<i>Parts of Detail Part</i>
					<i>Attaching parts for Parts of Detail Part</i>
					<i>(END ATTACHING PARTS)</i>

Attaching parts always appear at the same indentation as the item it mounts, while the detail parts are indented to the right. Indented items are part of, and included with, the next higher indentation. Attaching parts must be purchased separately, unless otherwise specified.

### Abbreviations

Abbreviations conform to American National Standards Institute (ANSI) standard Y1.1



**Figure 26: P7350 replaceable parts**

## Appendix D: Replaceable Parts

---

Fig. & index no.	Tektronix part no.	Serial no. Effective	Qty	12345 name & description	Mfr. code	Mfr. part no.
26-1	010-0708-XX		1	PROBE ASSEMBLY:SERVICE REPLACEMENT, SERIALIZED	80009	010-0708-XX
-2	200-4236-XX		1	COVER, PROBE TIP	80009	200-4236-XX
-3	016-1879-XX		1	CASE,STORAGE:PLASTIC, W/ANTISTAT FOAM	TK6108	016-1879-XX

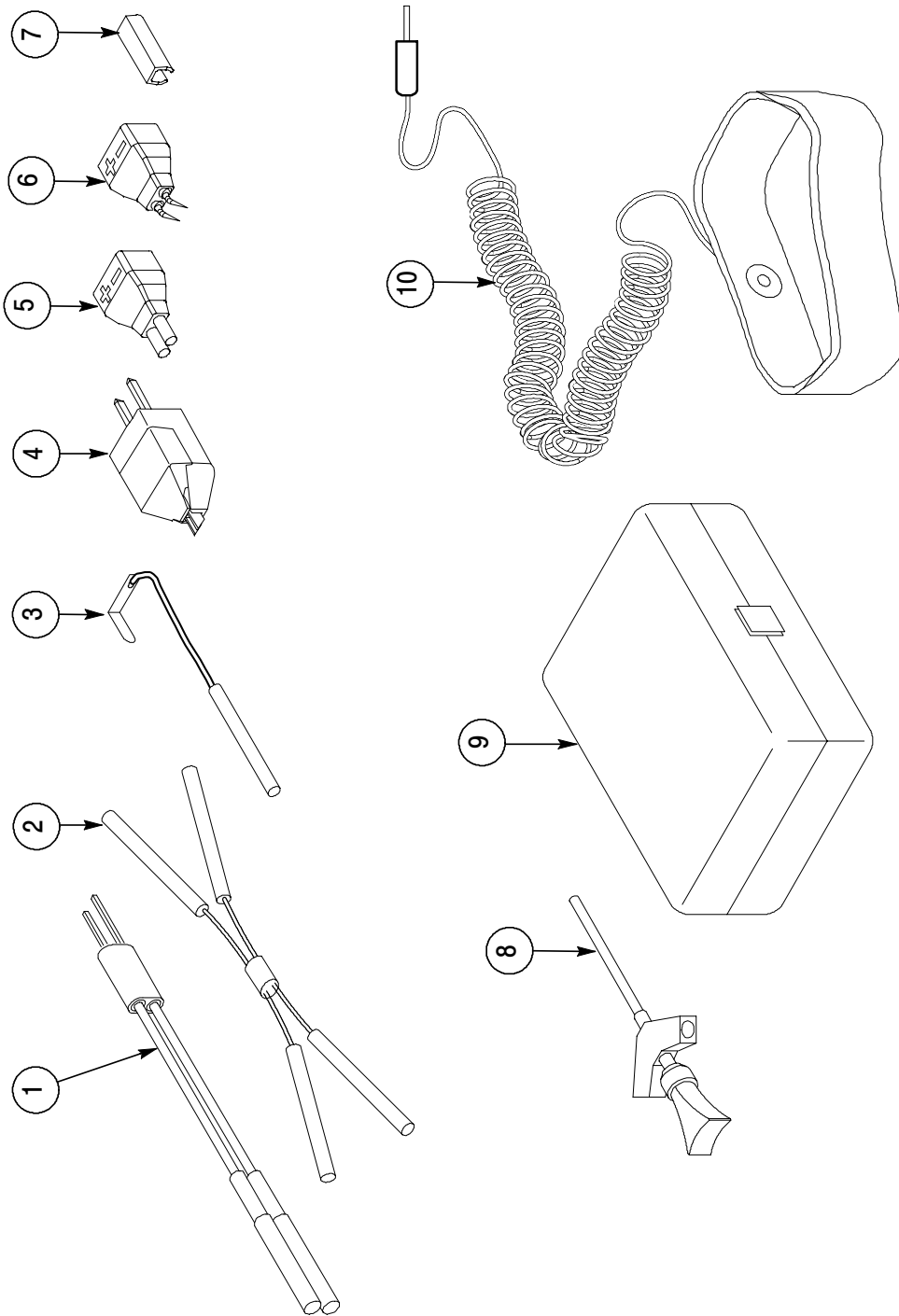
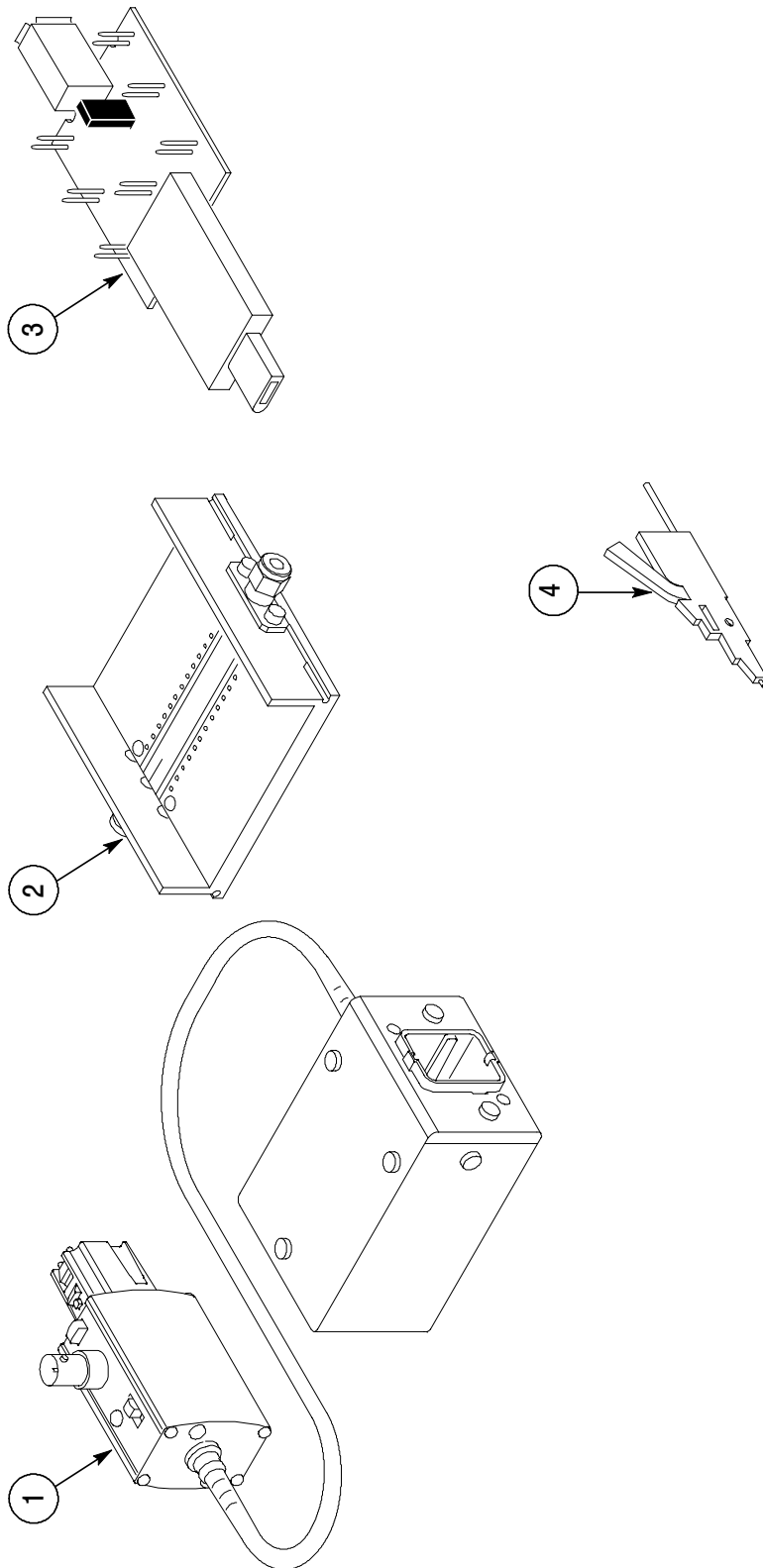


Figure 27: P7350 standard accessories

## Appendix D: Replaceable Parts

Fig. & index no.	Tektronix part no.	Serial no. Effective	Qty	12345 name & description	Mfr. code	Mfr. part no.
<b>STANDARD ACCESSORIES</b>						
27-1	196-3468-XX		1	LEAD, ELEC:DESCRETE,CPD,2,22 AWG,RED & BLACK,2.300 L,JACK TIP,PKG OF 2	060D9	196-3468-XX
-2	196-3473-XX		2	LEAD,PIN JUMPER:DIFF,FEMALE SQ PIN CONNECTOR TO FEMALE SQ PIN CONNECTOR,23 AWG,3.0 L,2 PAIR	060D9	196-3473-XX
-3	196-3469-XX		1	LEAD GROUND:GROUND LEAD,PKG OF 2		196-3469-XX
-4	016-1785-XX		1	ADAPTER:DIFFERENTIAL PROBE,PKG OF 4	80009	016-1785-XX
-5	016-1884-XX		1	ACCESSORY KIT:SQUARE PIN ADAPTER,PKG OF 4	060D9	016-1884-XX
-6	016-1885-XX		1	ACCESSORY KIT:VARIABLE SPACER ADAPTER,PKG OF 4	060D9	016-1885-XX
-7	016-1886-XX		1	MARKER KIT,ID:CABLE MARKER BAND,2 EA, VAR COLRS	80009	016-1886-XX
-8	206-0364-XX		2	TIP,PROBE:MICROCKT TEST,SMT KLIPCHIP	80009	206-0364-XX
-9	006-7164-XX		1	BOX,PLASTIC:4.625 X 2.875 X 1.0	80009	006-7164-XX
-10	006-3415-XX		1	STRAP,WRIST:3M TYPE 2214, ADJUSTABLE,6 FT COILED CORD	TK0623	RTI 8454001829
	071-1238-XX		1	MANUAL,TECH:INSTRUCTION,P7350	80009	071-1238-XX



**Figure 28: P7350 optional accessories**



Fig. & index no.	Tektronix part no.	Serial no. Effective	Dscont	Qty	12345 name & description	Mfr. code	Mfr. part no.
<b>OPTIONAL ACCESSORIES</b>							
28 -1	067-0422-XX			1	CALIBRATION FIXTURE ASSY:ECB TO TOP,P7000 SERIES	80009	067-0422-XX
-2	067-0419-XX			1	PROBE CALIBRATION FIXTURE	80009	067-0419-XX
-3	679-5027-XX			1	CKT BD SUBASSY:1394 ADAPTER	80009	679-5027-XX
-4	SMK4			1	TIP,PROBE:MICROCKT TEST,PKG OF 4	80009	SMK4

## CROSS INDEX - MFR. CODE NUMBER TO MANUFACTURER

Mfr. code	Manufacturer	Address	City, state, zip code
060D9	TENSOLITE CORPORATION	3000 COLUMBIA HOUSE BLVD, SUITE 120	VANCOUVER, WA 98661
26805	M/A COM OMNI SPECTRA INC	MICROWAVE CONNECTOR DIV 140 4TH AVE	WALTHAM, MA 02254
80009	TEKTRONIX INC	14150 SW KARL BRAUN DR PO BOX 500	BEAVERTON, OR 97077-0001
TK0623	GENERAL TOOL & SUPPLY CO	2705 NW NICOLAI ST	PORTLAND, OR 97210
TK2565	VISION PLASTICS INC	26000 SW PARKWAY CENTER DRIVE	WILSONVILLE, OR 97070
TK6108	KENT H LANDSBERG CO	27929 SW 95TH, SUITE 101	WILSONVILLE, OR 97070

