



ABN 43 064 478 842

231 Osborne Avenue Clayton South, VIC 3169  
PO Box 1548, Clayton South, VIC 3169  
t 03 9265 7400 f 03 9558 0875  
freecall 1800 680 680  
www.tmgtestequipment.com.au

## Test & Measurement

- > sales
- > rentals
- > calibration
- > repair
- > disposal

## Complimentary Reference Material

This PDF has been made available as a complimentary service for you to assist in evaluating this model for your testing requirements.

TMG offers a wide range of test equipment solutions, from renting short to long term, buying refurbished and purchasing new. Financing options, such as Financial Rental, and Leasing are also available on application.

TMG will assist if you are unsure whether this model will suit your requirements.

Call TMG if you need to organise repair and/or calibrate your unit.

If you click on the "Click-to-Call" logo below, you can call us for FREE!

TMG Corporate Website

TMG Products Website



Click-to-Call  
TMG Now

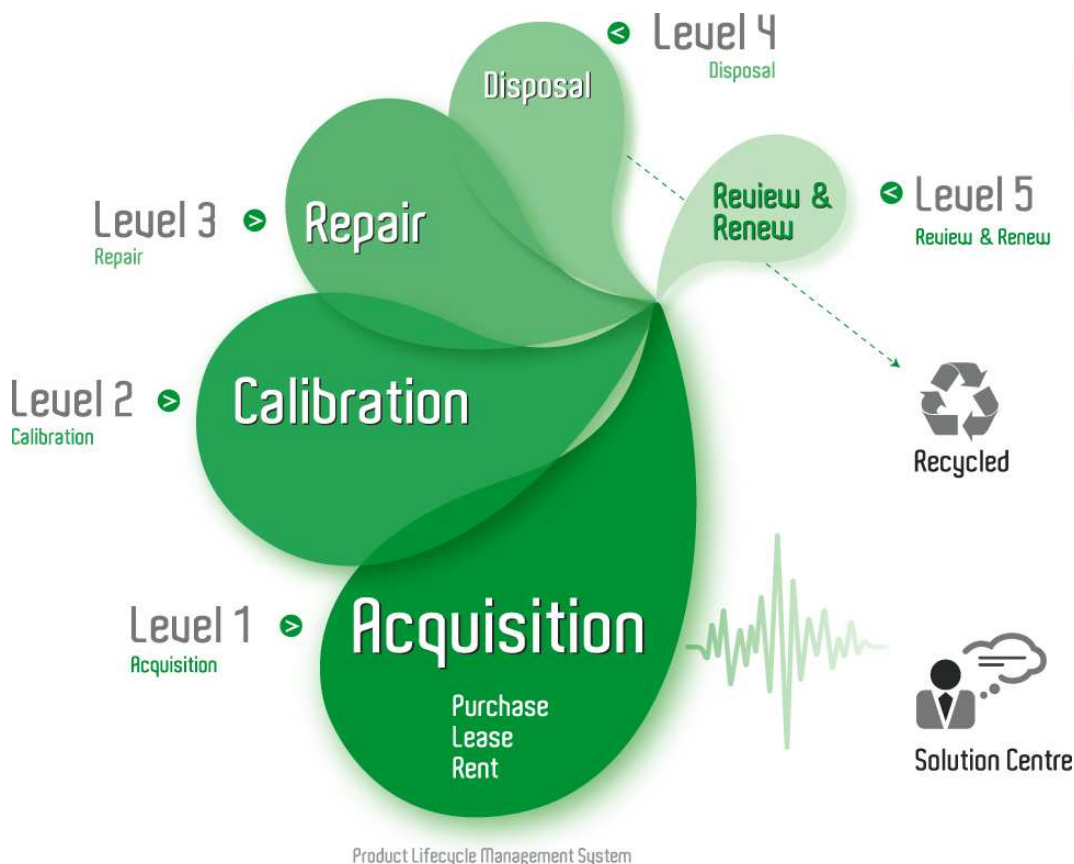

Product Lifecycle Management System

### Disclaimer:

All trademarks appearing within this PDF are trademarks of their respective owners.





# Trend **AuroraPlus**



## User Guide



**Trend**Communications

**429850**

Issue 5 - 04/01



## **Copyright Notice**

The information contained in this document is the property of Trend Communications Ltd. and is supplied without liability for errors and omissions.

No part of this document may be reproduced or used except as authorised by contract or other written permission from Trend Communications Ltd. The copyright and all restrictions on reproduction and use apply to all media in which this information may be placed.

Trend Communications Ltd. pursue a policy of continual product improvement and reserve the right to alter without notice the specification, design, price or conditions of supply of any product or service.

The Trend **Aurora** name is a registered trademark of Trend Communications Limited.

**Windows** is the registered trademark of Microsoft Corporation.

© **Trend Communications Ltd. 2001**

All rights reserved

Publication ref: 429850

Issue 5 - 04/01

**Trend Communications Ltd.**

**Knives Beech Estate,**

**Loudwater,**

**High Wycombe,**

**Buckinghamshire,**

**HP10 9QZ**

**U.K.**

**TEL: +44 (0) 1628 524977**

**FAX: + 44 (0) 1628 810094**

**email: [trend.infoline@trendcomms.com](mailto:trend.infoline@trendcomms.com)**

## **International Contact Addresses**

**Trend Communications S.A.**

**Burospace - Bât 7**

**Route de Gisy**

**91571 BIEVRES CEDEX**

**FRANCE**

**TEL: + 33 1 69 35 54 70**

**FAX: + 33 1 60 19 00 48**

**Trend Communications GmbH**

**Valerystr. 1**

**85716 Unterschleißheim b. München**

**GERMANY**

**TEL: + 49 89 32 30 09 (0)**

**FAX: + 49 89 32 30 09-99**

**Trend Communications SRL.**

**v. Cavriana 3**

**20134 Milano**

**ITALY**

**TEL: + 39 02 7391.414**

**FAX: + 39 02 7391.309**

**Trend Communications s.l.**

**Pujades, 60**

**08005 Barcelona**

**SPAIN**

**TEL: + 34 93 300 3313**

**FAX: + 34 93 309 2385**

**Trend Communications  
C-207 Twin Arcade  
Military Road  
Marol Andheri (East)  
Mumbai 400059  
INDIA**

**TEL: + 91 228 597463**

**FAX: + 91 228 596155**

## **Help Desk Numbers**

If you have any queries about the operation of **AuroraPlus**, you can contact the Trend Communications Ltd. Help Desk:

*From within the UK: 08457 660 854 (local rate)*

*From France: (1) 69 35 54 75*

*From Germany: (0) 89-32 30 09-44*

*From other non-UK countries: +44 1628 851085*

*For sales enquiries, talk to your local Trend Communications representative.*

## **Web Site Information**

[www.trendcomms.com](http://www.trendcomms.com)





# Contents

<b>Introducing AuroraPlus .....</b>	<b>1-1</b>
Welcome ! .....	1-1
Conventions in the Guide .....	1-2
Your AuroraPlus .....	1-4
Types of AuroraPlus .....	1-4
Features .....	1-4
Use .....	1-7
Supplied with AuroraPlus .....	1-8
Looking after AuroraPlus .....	1-8
Safety Advice .....	1-8
Where to get more information .....	1-9
ISDN Explained .....	1-10
What is the ISDN? .....	1-10
ISDN Services .....	1-10
Equipment on the ISDN .....	1-11
ISDN Interfaces .....	1-11
ISDN Standards .....	1-12
Pulse Code Modulation .....	1-12
Methods of Voice Encoding .....	1-12
Line Coding Techniques .....	1-13
Basic Rate & Primary Rate ISDN .....	1-13
The OSI 7-Layer Model .....	1-15
Layer 1 (BRI) .....	1-16
Layer 2 .....	1-17
Layer 3 .....	1-17
Protocols .....	1-18
<b>Getting Started .....</b>	<b>2-1</b>
A Look at AuroraPlus .....	2-2
The Keypad .....	2-3
Switches .....	2-4
S/U Change-Over Switch .....	2-4
POTS Check Switch (Only via U Access Cable) .....	2-5
Battery Charging Switch (Optional) .....	2-6
Termination Resistor Switch (TERM) .....	2-6
Interface Switch (Optional) .....	2-7
Communication Ports & Connectors .....	2-8
Connecting AuroraPlus .....	2-9
Switching Power On .....	2-11

- Displaying the Main Menu ..... 2-12
- Scrolling through Menu Pages ..... 2-12
- Selecting Menu Options ..... 2-13
  - Exiting from a Menu ..... 2-14
  - Returning to the Main Menu ..... 2-14
- Using Hot Keys ..... 2-14
  
- Setting Up your AuroraPlus ..... 3-1**
  - Displaying the Setup menus ..... 3-1
  - Selecting Protocol & Line Type ..... 3-1
    - Changing the Protocol ..... 3-2
    - Changing the Line Type ..... 3-2
  - Setting up a Loop ..... 3-3
    - Changing the Loop Options ..... 3-4
  - Call Screening ..... 3-5
  - Address Setup: Setting CPN Sub-address & CLI ..... 3-6
  - Address Setup: Setting CLI Presentation/Restriction ..... 3-7
  - Setting up a CUG (Closed User Group) (ETSI) ..... 3-9
  - Setting the BER Test Length ..... 3-10
  - Tracer Setup ..... 3-12
  - Entering the Date and Time ..... 3-13
  - Storing Speed Dialling Numbers ..... 3-14
  - Changing the Language ..... 3-15
  - Loudspeaker Volume Settings ..... 3-16
  - Default Settings ..... 3-17
  
- Call Establishment ..... 4-1**
  - Making a Call ..... 4-1
    - Dialling ..... 4-1
    - DTMF tones ..... 4-4
    - Clearing a Call ..... 4-5
    - Speed Dialling ..... 4-6
    - Call Redial ..... 4-6
  - Answering Incoming Calls ..... 4-7
  - Call Waiting ..... 4-8
    - Dealing with a Second Call ..... 4-8
  - Placing a Call on Hold ..... 4-9
    - Making an Outgoing Call During an Existing Call ..... 4-9
    - Accepting an Incoming Call During an Existing Call ..... 4-11
  - Selecting an ISDN Service ..... 4-12

Setting up a User-Defined Bearer Service (ETSI) (1TR6) .....	4-14
Entering Hexadecimal Numbers .....	4-15
Setting the Bearer Capability (ETSI) .....	4-16
Setting the Low Layer Capability (ETSI) .....	4-16
Setting the High Layer Capability (ETSI) .....	4-17
Setting the Bearer Service (1TR6) .....	4-17
Channel Setup .....	4-18
Supplementary Service Selection .....	4-20
Call Forwarding (TPF) .....	4-20
Call Deflection .....	4-29
Keypad Facility (ETSI) .....	4-30
Malicious Call Identification (MCID) .....	4-36
Making a Three Party Call .....	4-37
Setting up CCBS (ETSI) (VN) (TPH)	
(Completion of Calls to Busy Subscribers) .....	4-40
Making a Call with CCBS Enabled .....	4-41
CCBS Error Messages .....	4-44
CCBS Options Not Supported by AuroraPlus. ....	4-44
Suspending and Resuming a Call (ETSI) .....	4-44
User-to-User Signalling (ETSI) .....	4-46
Setting up User-to-user Signalling .....	4-46
Sending an INVOKE Request .....	4-50
Choosing how AuroraPlus Responds to UUS INVOKE Requests .....	4-52
<b>Test Functions .....</b>	<b>5-1</b>
Autotest .....	5-1
Setting up the Autotest .....	5-1
Running the Autotest .....	5-2
Checking the Line Configuration .....	5-3
Automatically configuring the line under test .....	5-4
Service Check: Determining Available Services .....	5-4
Performing a Local Service Check .....	5-5
Performing a Remote Service Check .....	5-6
Understanding Service Check Results .....	5-6
The X.25 Test .....	5-7
Testing Fixed Links .....	5-8
Performing a BER Test .....	5-8

- Downloading BERT Results to a PC ..... 5-9
- Starting a BER test ..... 5-10
- Understanding the BER Test Results ..... 5-13
- Displaying Test Results ..... 5-15
  - Displaying Tracer Output ..... 5-16
  - Downloading Tracer Results to a PC ..... 5-17
  - Clearing Tracer from Memory ..... 5-18
- Saving Results ..... 5-19
  - Saving a Set of Results ..... 5-19
  - Displaying Results You Have Saved ..... 5-20
- Sending Results to a PC ..... 5-20
  - Entering the Customer and Operator Names ..... 5-20
  - Sending the Report ..... 5-21
- Self Test Functions ..... 5-22
  - Performing a Self Test Function ..... 5-23
  - Upgrading AuroraPlus Software ..... 5-26
- Performing a Status Check ..... 5-29
  - Checking Call Forwarding Status **(ETSI)** ..... 5-29
  - Checking Call Forwarding Status **(VN)** ..... 5-31
  - Checking Active Facilities **(ITR6)** ..... 5-31
- Displaying Far End Block Errors/Near End Block Errors (FEBE/NEBE) ..... 5-33
- Checking AuroraPlus's Status and the Line Voltage ..... 5-34

**X.25 Calls ..... 6-1**

- What is D-channel X.25 ? ..... 6-1
- Setting up an X.25 call ..... 6-1
- Connecting a X.25 Call ..... 6-8
  - Receiving X.25 Calls ..... 6-12

**Spectrum B Stimulus and Functional (Optional) . 7-1**

- Introduction ..... 7-1
  - SPIDS (Service Profile Identifier) ..... 7-1
- Spectrum B Functional ..... 7-1
  - Bearer and teleservices ..... 7-1
  - Supplementary Services ..... 7-2
- Spectrum B Stimulus and Functional ..... 7-2
  - Main Menu ..... 7-2
  - Changing the SPID (Service Profile Identifier) ..... 7-3
  - Spectrum Stimulus Call Setup ..... 7-5
  - Performing a BER test ..... 7-6
  - Viewing messages sent by the network ..... 7-7

**Testing on Analogue Lines with AuroraPlus (Optional) ..... 8-1**

- Preparing AuroraPlus for Analogue Lines ..... 8-1
- Analogue Setup ..... 8-2
  - Setting the Dial Mode ..... 8-2
  - Storing Speed Dial Numbers ..... 8-2
  - Setting Language & Loudspeaker Options ..... 8-3
- Answering Incoming Calls ..... 8-3
- Making Outgoing Calls ..... 8-4
  - Overlap Dialling ..... 8-4
  - En Bloc Dialling ..... 8-5
  - Speed Dialling ..... 8-6
- While a call is connected ..... 8-6
  - Switching between Pulse and DTMF dialling ..... 8-7
  - Putting a call on hold ..... 8-8
  - Displaying the Meter Pulse Count ..... 8-9
- The 40kHz Generation Test ..... 8-10

**Technical Data ..... A1-1**

**Glossary and Acronyms ..... A2-1**

**Menutrees ..... A3-1**

**Call Clearing Cause Codes ..... A4-1**

**Index**



# Introducing AuroraPlus

# 1

This chapter introduces you to the documentation provided with **AuroraPlus** and the conventions used throughout it. It also outlines the main features of **AuroraPlus** and provides an introduction to ISDN.

## Welcome !

Welcome to the Trend **AuroraPlus** User Guide. This guide contains information on using your **AuroraPlus** together with safety information, technical details and an introduction to ISDN. If you are a new user you may find it helpful to spend time familiarising yourself with this guide so that you know where to find information when you need it. The structure of the guide is as follows :

**Chapter 1** (this chapter) introduces you to **AuroraPlus** and to ISDN.

**Chapter 2** describes the controls, switches, connectors and power supply. Also discussed is how to display, select from and navigate through the menu structure.

**Chapter 3** tells you how to set up **AuroraPlus** in preparation for testing.

**Chapter 4** describes how to accept and make voice and data calls.

**Chapter 5** describes how to perform various test functions with your **AuroraPlus** - for example a BER Test or a Service Check.

**Chapter 6** describes how to use **AuroraPlus** to test in X.25 generic packet mode.

**Chapter 7** describes how to use **AuroraPlus** to test on a network using Spectrum B Functional or Spectrum B Stimulus.

**Chapter 8** describes how to use **AuroraPlus** to test on analogue lines.

**Appendix 1** lists technical information relevant to your **AuroraPlus**.

**Appendix 2** provides a glossary of terms and abbreviations used throughout this Guide.

**Appendix 3** contains menutree diagrams to help you navigate through the menu structure.

**Appendix 4** explains the Cause Code and clearing location information provided by **AuroraPlus**.

## Conventions in the Guide

The conventions used throughout this Guide are explained below:

### Protocol Symbols

Differences between the public protocols supported by **AuroraPlus** (ETSI, 1TR6, TPH and VN) are indicated throughout this guide using symbols. For example, text that applies to VN only is indicated using:



Text that does *not* apply to VN is indicated by a line through the symbol :



Unlabelled text applies to all protocols.



## Special Typefaces

To help you distinguish them, menu options are shown in a different typeface - for example 'choose **SETUP**'.

The names of keys are displayed in bold, italic typeface - for example 'press ***ENTER***'.

## Other Symbols



*Tip*

Indicates a useful tip.



*Note*

This symbol is used to draw your attention to important notes.



*Hot Keys*

Indicates the Hot Key combination to access the function quickly.



*Warning*

This symbol highlights warnings or cautionary notes.



## Notes

- ETSI is used to denote the Euro ISDN protocol throughout this manual.
- The text and illustrations in this *User Guide* describe a typical **AuroraPlus**. They may not match your specific configuration and may include features that you did not purchase.
- The text and illustrations in this *User Guide* describe all the features available on **AuroraPlus**. You may not be able to select certain menu items if your organisation did not purchase these options.
- The term reference point and interface (R, S, T, S/T or U) are used interchangeably.
- The term 'S bus' refers to an 'S' Point-to-Multipoint connection, while S usually refers to a Point-to-Point connection known as the 'T' reference point.
- The term 'POTS' (Plain Old Telephone System) is used to refer to the service that is also known as PSTN or analogue telephony.

## Your **AuroraPlus**

**AuroraPlus** is an easy-to-use, hand-held Basic Rate ISDN tester. It enables various types of ISDN calls and connections to be tested and its menu-driven display allows easy operation and programming. **AuroraPlus** contains many of the features associated with a modern ISDN telephone *and optionally* a standard analogue telephone. **AuroraPlus** can also perform audio monitoring on an analogue telephone line.

## Types of **AuroraPlus**

Various types of **AuroraPlus** unit are available. There are three basic types, classed according to region of operation and the type of line coding in use on the ISDN 'U' interface:

- non-US 2B1Q unit
- US 2B1Q unit
- 4B3T unit

Within these basic types there are other options related to the power source for the unit:

- Line powered unit - power is taken from the line.
- Battery powered unit - you can power the unit from a battery, the optional charger or the ISDN line. Available with all basic unit types.
- 'Combi' unit - a battery powered unit which can also be used to test analogue telephony. Available with all basic unit types.

## Features

- 4 x 12 line character, backlit display providing an easy-to-navigate, intuitive menu structure.
- Easy-to-use keypad providing:
  - 'Hot Keys' for direct access to functions
  - Direct DTMF support with \* and #

- Operation on U (2B1Q or 4B3T) and S/T interfaces.
- Protocols: ETSI (Euro ISDN) 1TR6 and VN.
- Support for both Point-to-Point operation ('T' reference point) and Point-to-Multipoint (S-bus) operation.
- Call state and layer state information.
- Supplementary Service Support including:
  - Call Hold and Retrieve
  - Call Forwarding
  - Call Waiting
  - 3 Party Conference Call Facility
  - CCBS
  - Call Deflection
  - Terminal portability
  - User to User Signalling
- Support for bearer and teleservices:

**TPH**

Tele-ISDN  
 3.1k Audio  
 Telefax Group 3  
 Telefax Group 4  
 Data 64 kbit/s  
 Teletex 64  
 Telex  
 Mixed Mode  
 SVideo  
 PVideo  
 Videotext  
 OSI  
 Timelink  
 tele-check  
 Audiovisual  
 tele-check  
 User defined  
 Speech  
 X.25 D channel

**ETSI & 1TR6**

Tele-ISDN  
 3.1k Audio  
 Data 64 kbit/s  
 Telefax Group 3  
 Telefax Group 4  
 Speech  
 Data 56 kbits/s  
 Teletext 64  
 X21UC4  
 X25UC8  
 BTX  
 BTX New  
 Audiovisual  
 Mixed Mode  
 Remote Control  
 GRPTEL  
 X.25 D channel  
 tele-check  
 User-defined

**VN**

Tele-ISDN  
 3.1 Audio  
 Telefax Group 3  
 Telefax Group 4  
 Data 64 kbit/s  
 Teletex 64  
 Telex  
 Speech  
 7k Audio  
 7k Telephony  
 Data 56 kbit/s  
 Mixed Mode  
 Video  
 Videotex Syntax  
 Videotex Int'l  
 OSI  
 tele-check  
 Video phone  
 MSGPRO  
 X.25 D channel  
 User-defined

- Storage of up to 99 lines of D channel protocol data which can be reviewed on-screen or downloaded.
- Serial Port
  - to flash EPROMs for software upgrade
  - to output stored data
- BER Testing with a range of duration times
- X.25 Testing
- Facility for checking services available from the exchange and the acceptance of calls at 'R', 'S', 'T' and 'U' reference points over the Basic Rate ISDN
- Audio monitoring function on a two-wire interface
- Self Testing
- Call Redial
- 5 'Speed Dial' number entries
- Setting of Multi-Subscriber Number (MSN) in the ETSI protocol
- Testing of voiceband and data calls
- Displays A-subscriber numbers (Calling Line Identity) during calls
- Display of line voltage on analogue (POTS), U and S connections
- Display of number while dialling
- Power feed from U or S/PS1 normal or restricted mode
- Unit protection via a short-circuit of direct supply voltage
- Voltage resistant up to 240V DC on the U Interface
- Ringer. An incoming call is signalled via the built-in ringer.
- Retention of all programmed data in nonvolatile memory after the tester is disconnected from the network or switched off.

- Loudspeaker monitor
- 40 kHz generator at -12dBm for a two-wire interface with a TIMS test set
- Loop formation on analogue lines (POTS)
- Analogue standard telephone (optional)
- Battery operation (optional)

## Use

You can use your **AuroraPlus** held in the hand, like a telephone handset, or laid on its back. There is also a hook (two on the 'combi' model) on the back of **AuroraPlus** so that you can hang it up.

Your **AuroraPlus** is designed to test the ISDN Basic Rate Interface (BRI) at the 'S', 'T' and 'U' reference points, by emulating a Terminal Equipment (TE).

Making and clearing a Basic Rate connection between the terminal and the network uses a D channel communication protocol. **AuroraPlus** tests the correct operation of this protocol and reports the success or failure of the call on its Liquid Crystal Display (LCD). Please note that detailed explanations of application protocols are not included in this guide.

When you have made or answered an ISDN call, (either voice or data) **AuroraPlus** lets you test the integrity of the connection. For voice calls, this may be a speech test or Bit Error Rate (BER) Test and, for data calls, a BER Test.

## Supplied with **AuroraPlus**

**AuroraPlus** is supplied with the following items:

- a 6-pole RJ45 to RJ45 cable for S interface testing
- for French units, a cable with 4m 'banana' plugs and crocodile clips for U interface testing
- a serial port connector cable for direct communication with a PC serial port
- installation software, where required
- for battery and analogue units, a power charger (European, US or UK)
- this User Guide
- a carrying case (optional accessory)

## Looking after **AuroraPlus**

**AuroraPlus** has been designed and constructed to withstand the rigours of a typical telecommunications working environment. It can be used in wet conditions but is not waterproof and will not withstand excessive ingress of water.



### **Caution**

Do not use solvents, strong detergents, or abrasive materials to clean your **AuroraPlus**. Use only cleaning agents approved for use on plastics.

## Safety Advice

When using **AuroraPlus**, basic safety precautions should always be followed to reduce the risk of fire, electric shock or injury, including the following:

- The serial port, the DC Power Input Connector and the Interface Connector must not be connected to mains power outlets. The Interface Connector should only be connected to authorised ISDN or analogue lines.

- When supplied with a power adaptor/charger, **AuroraPlus** must only be used with that adaptor/charger. The use of any other adaptor/charger may invalidate approvals relating to safety or electromagnetic compatibility.
- Do not open the back of the unit when it is switched on or connected to the network.
- Avoid using the product during an electrical storm. There may be a remote risk of electrical shock from lightning.

## Where to get more information

If you would like more information about **AuroraPlus** or other Trend products, contact your sales representative or the Trend Communications Ltd. Help Desk:

*Within the UK:* **08457 660 854** (local rate)

*Within France:* **01 69 35 54 75**

*Within Germany:* **(0) 89-32 30 09-43**

*Other countries:* **+ 44 1628 851085**

# ISDN Explained

## What is the ISDN?

The ISDN is an evolutionary circuit switched network based on digital telephony. It uses a common set of interface standards and allows users to send and receive information over the network.

ISDN offers end-to-end (caller to receiver) digital connectivity between Terminal Equipment (TEs), via Network Terminators (NTs) and digital exchanges, both private and public.

## ISDN Services

ISDN services are the telecommunication services to which the user has access either at an ISDN interface or a terminal connected to the ISDN. The diagram below summarises the services offered:

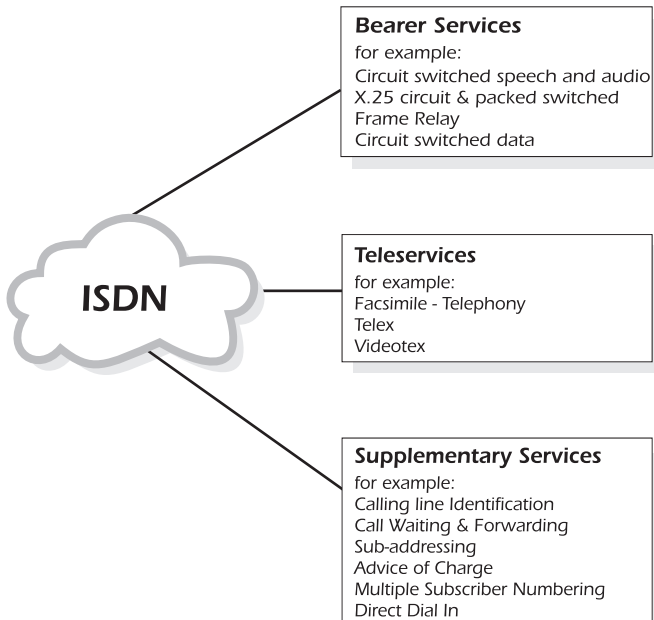



## Equipment on the ISDN

Each piece of equipment ('functional group') on the ISDN has a label related to the function it performs. The labels are:

ISDN Equipment	
TE1	Terminal Equipment type 1. Uses and supports ISDN protocols and services.
TE2	TE type 2 - for example, non-ISDN compatible devices such as analogue telephones, PCs and printers.
NT1	Network Termination type 1. Terminates the ISDN line at the user's site.
NT2	NT type 2. Provides customer site switching, multiplexing and concentration, e.g. an ISDN PABX.
TA	Terminal Adaptor. Used to allow non-ISDN devices (TE2s) to access the ISDN network.
LTs	Line Termination equipment. Terminates the ISDN line at the local exchange.

## ISDN Interfaces

An interface ('reference point') is said to exist between each piece of equipment on the ISDN.

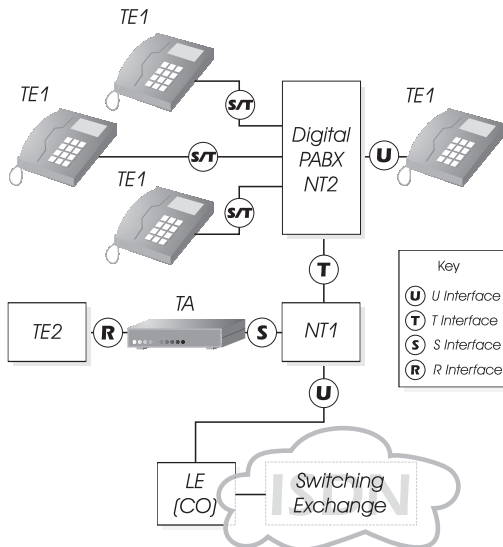



## **Notes**

In a typical BRI installation NT1 and NT2 functions are combined in single NTE (Network Termination Equipment).

## **ISDN Standards**

ISDN is subject to standardisation by the ITU-T and ETSI, which issue recommendations and specifications covering ISDN equipment and interfaces. Standards also exist for types of service, protocols and ISDN numbering.

## **Pulse Code Modulation**

Pulse Code Modulation (PCM) is a method of converting analogue signals into digital code. An analogue waveform is sampled at regular intervals and a measurement is taken of the sample point at various levels. The number obtained is digital. The receiver recovers the original analogue signal by reversing the conversion.

The sampling rate is 8kHz, and the sample value is translated into an 8 bit code, to conform with ITU-T G.711. Therefore each speech signal results in a continuous bit stream at a rate of 64 kbps.

The process of converting between analogue and digital is known as encoding. An encoding device when combined with a decoder is called a Codec.

## **Methods of Voice Encoding**

The number of levels used in the sampling, and the way they are spread, affect the amount of signal noise and distortion. There are two methods of encoding within the ITU-T G.711 recommendation: A-Law and  $\mu$ -Law.

### **A-Law encoding**

This is the type of voice encoding used in Europe. Sampling consists of 4096 levels, divided into 7 segments.

### **$\mu$ -Law encoding**

This is the type of encoding used in the United States, Japan and some other regions of Asia. Sampling consists of 8159 levels, divided into 8 segments.

## **Line Coding Techniques**

To overcome the technical difficulties raised by sending digitised information down a telephone cable originally designed for 50V pulse dialling and 4kHz speech, line coding is used. There are a number of different techniques: each one involves coding digitised speech into different voltages which can then be transmitted down the telephone lines.

### **2B1Q line coding**

The name 2B1Q comes from the method of coding 2 binary digits (2B) as one of 4 voltage levels (1Q, where Q stands for 'quaternary').

### **4B3T line coding**

The name 4B3T comes from the method of coding 4 binary digits (4B) as a group of 3 voltage levels (3T, where T stands for 'ternary').

## **Basic Rate & Primary Rate ISDN**

Equipment on an ISDN network may be connected either through a Basic Rate interface or a Primary Rate interface.

- Basic Rate (BRI) consists of two B channels and one D channel, known collectively as 2B+D.
- Primary Rate (PRI) consists of 30 B channels and one D channel ('30B+D') in Europe, and 23 B channels and one D channel ('23B+D') in the US.

The B channels contain user data at rates of up to 64Kbps. The data is switched by the network in order to provide an end-to-end transmission service.

In Basic Rate the D channel carries control and signalling data at 16kbps. It may also be used for X.25, the Packet mode service.

### **Basic Rate access to the ISDN**

The diagram below illustrates Basic Rate ISDN operation.

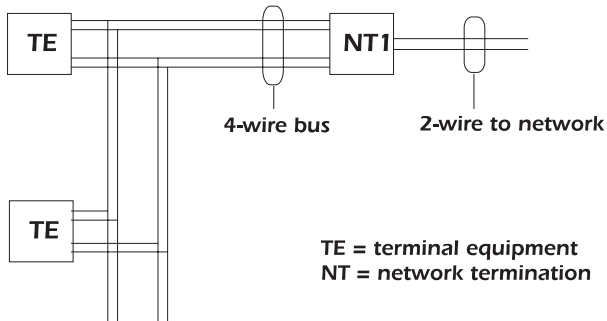

In this illustration, a 4 wire interface consisting of a transmit and receive pair (known as the 'S/T interface'), is connected to the NT1. The S/T interface is terminated at the NT1 and the distant end, on both the transmit and receive pairs. Connection to the interface is usually made via 8-pin plugs which conform to ISO Specification 8877. Over this interface pass the 2B+D channels.

### **Point-to-Point and Point-to-Multipoint links**

The layer 2 of a S/T interface can operate in either Point-to-Point (PP) or Point-to-Multipoint (PMP) mode.

- On a PP link, only one TE may be connected at the end of up to 1km of cable.
- On a PMP link, up to 8 terminals can be connected in parallel along the bus. The length of the bus is limited to about 200m, depending on the cable.

### **Basic Rate power**

Power is provided across the network so that, in the event of a local mains power failure, a basic telephone service is still provided.

## **The OSI 7-Layer Model**

The Open Systems Interconnection (OSI) is an agreed, international standard governing the way systems communicate. The standard model has seven layers, as follows:

- Layer 1**      The physical layer. Transmits bits between the terminal and the network. It defines connectors, line coding, transmission rates and anything else concerning the transfer of bits.
- Layer 2**      The data link layer. Provides link level control. Error detection and correction are handled by assembling the bits into frames. All Layer 2 formats derive from a standard known as High Level Data Link Control (HDLC).
- Layer 3**      The network layer. Routes messages to their destination.
- Layer 4**      The transport layer. The end-to-end layer which sets up and maintains connections.
- Layer 5**      The session layer. Handles the co-ordination between processes.
- Layer 6**      The presentation layer provides data formatting and code conversion.
- Layer 7**      The application layer. This is the task to be performed, e.g. remote login and file transfer.

## Layer 1 (BRI)

Layer 1, at the S/T reference point, transfers information bits in frames between the terminals and the NT1.

Each layer 1 frame is 48 bits long and lasts for 250 microseconds—its structure depends on the direction of transmission. It contains two 8 bit groups of channel B1, two 8 bit groups of channel B2, 4 bits of channel D and 12 bits used for other functions.

### D Channel Contention

If two TEs attempt to make a call simultaneously, a procedure known as D Channel Contention Resolution prevents a collision.

### Activation and deactivation

TEs and NTs can be deactivated in order to reduce power consumption, then reactivated to normal power. Both the TE and NT can receive activation messages, but only an NT can instruct a TE to deactivate.

### 'Info' signals

Activation and Deactivation messages are transmitted using 'Info' signals.

**Info 0** idle state—neither the TEs or the NT are operating.

**Info 1** TE to NT—requests activation.

**Info 2** NT to TE—requests activation/responds to Info 1.

**Info 3** TE to NT—contains operational data.

**Info 4** NT to TE—contains operational data.

## Layer 2

Layer 2 provides a secure, error-free connection for Layer 3 call control information, by organising the Layer 3 octets into error checked frames. Layer 2 procedures, based on HDLC, are known as Link Access Procedure for a D Channel (LAPD).

A Layer 2 frame is structured as follows:

<b>Flag</b>	<b>Address</b>	<b>Control</b>	<b>Information</b>	<b>Frame Check Sequence</b>	<b>Flag</b>
-------------	----------------	----------------	--------------------	-----------------------------	-------------

- Flags** Indicate the start and end of the frame.
- Address** A unique value identifying the message type and the channel to which it refers. Contains a SAPI (Service Access Point Identifier) to identify the service that the frame is intended for, a TEI (Terminal Endpoint Identifier) to identify the terminal, and a Command/Response bit.
- Control** Carries information that identifies the frame.
- Information** Carries the TEI management protocol or layer 3 message.
- FC Sequence** Used for error detection.

## Layer 3

Layer 3 routes messages to their destination. The diagram below shows the structure of the Layer 3 signalling messages.

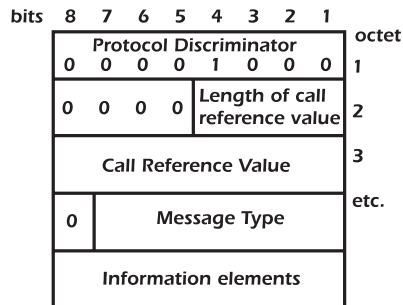

<b>Protocol Discriminator</b>	Identifies the protocol.
<b>Call Reference Value</b>	Identifies the call with which a message is to be associated.
<b>Message Type</b>	Describes the intention of the message: CONNECT, SETUP, etc.
<b>Information Elements</b>	A number of these may be included. The number and content depend on the message type.

## Protocols

A protocol is an agreed set of rules for carrying out a particular function such as the exchange of information.

### ETSI

The ITU Q921 and Q931 recommendations are the basis of what is commonly known as the ETSI protocol. Q931 defines the call control messages and Q921 defines the frames that carry the messages. ETSI is the standard ISDN protocol used within Europe.

### VN

VN is the national ISDN protocol for France and it is also used in private networks utilising equipment of French origin. VN is similar in many respects to the ETSI protocol, the main differences being the construction of layer 3 messages and information elements, new message types and different teleservices.



**1TR6**

The national protocol for the ISDN environment in Germany. Also often used in private networks utilising equipment of German origin.

**TPH**

The national protocol for the ISDN environment in Australia. Also often used in private networks utilising equipment of Australian origin.



# Getting Started

# 2

This chapter describes the controls, switches, connectors and power supply. Also discussed is how to display menus, scroll through them and select options.



## Note

If your **AuroraPlus** is fitted with batteries (battery and combi units) it was supplied with the batteries uncharged. We recommend that you fully charge the batteries before starting to use **AuroraPlus**.

NiMH cells exhibit a 'memory', which means that if you repeatedly recharge a battery which is only partially discharged, a small amount of its capacity is lost. This should not normally be a problem, but approximately once a month you may wish to discharge the battery completely before recharging it.

## A Look at **AuroraPlus**

Controls, switches and connections are shown in the following illustration.

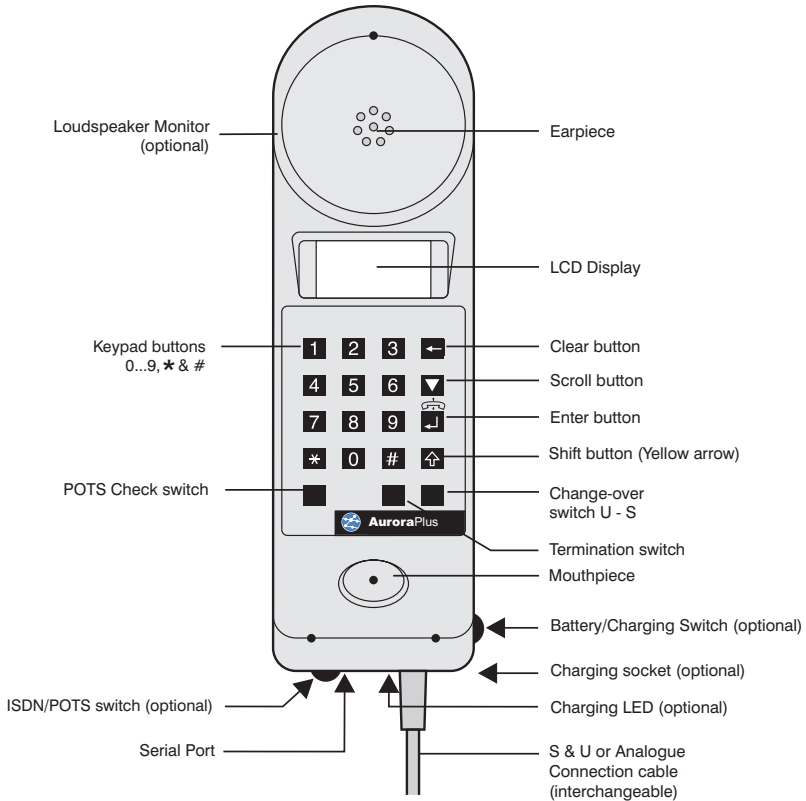

## The Keypad

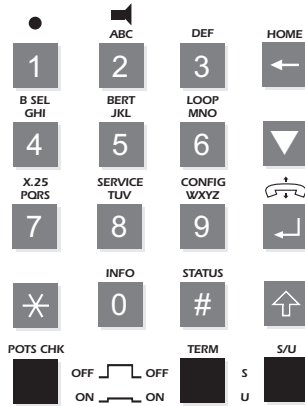

These are numeric keys for dialling digits and entering numbers. Keys 0 to 9 can be used for dialling numbers, entering codes and selecting functions. They form the keypad of the **AuroraPlus**.



### Clear Key

In screens that allow you to enter a number (for example, the Dial screen) this key deletes the most recently entered digits that appear on the display. In all other screens, press this key once to move up a level in the menu structure. Also, use with the *SHIFT* key to return 'home' to the Main Menu.



### Scroll Key

This is used to display more information when ▼ appears on the screen.



### Enter Key

This key is used to initiate or terminate a call. The *ENTER* key can also be used for making selections.



### Shift Key

The *SHIFT* key is used in combination with other keys to access additional functions - these are known as Hot Key functions. When you toggle the *SHIFT* key an 'S' appears in the top, right of the screen to indicate you are about to trigger a shift function:

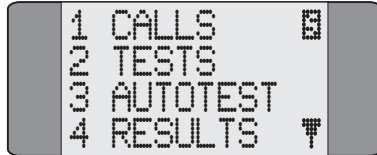

Functions displayed in yellow on the keypad are accessed by combining that particular key with *SHIFT* - for example  + 5 for a BER Test. Please refer to *Using Hot Keys* in this chapter for further details.

## Switches

### S/U Change-Over Switch

The S/U Change-Over Switch is used for switching between S or U Interface lines. The supplied S and U access cables are used for connection to the Basic Rate line. The switch has two positions:

**UP**            S Interface

**DOWN**        U Interface

#### Changing between S-Bus and U-Interface operation

With **AuroraPlus** switched on, unplug the connection to **AuroraPlus**.

Press the S/U button.

**AuroraPlus** reboots and the new interface is now active.

Connect the new connection to the RJ45 connector located at the base of **AuroraPlus**.

The Network Terminator (NT) must be disconnected before connecting **AuroraPlus** to a U Interface line. The Terminal Equipment (TE) must be disconnected before **AuroraPlus** is connected to an S Interface Point-to-Point connection.

After connection onto either the S or U Interface, the display indicates **Idle**. When you try to make a call the unit initialises the connected interface. On the S Interface this is almost instantaneous and is not visible. On the U Interface this can take a minute or so. During this time **INIT U** is displayed. When the interface is initialised, the call progresses to the next stage of the call establishment procedure.

## POTS Check Switch (Only via U Access Cable)

The POTS Check function is activated by the POTS Check Switch, marked '**POTS CHK**'. The high impedance circuitry means that the handset can be used to listen to analogue signals on the line. The switch has two positions:

**UP**            POTS Check is off

**DOWN**        POTS Check is on

When the **TERM** switch is in the **DOWN** position, if the line is idle, when you press the **TERM** Switch the unit draws analogue dial-tone.



### Important Note

The **POTS CHK** switch must be in the **UP** position, before connecting **AuroraPlus** to the U Interface line, to avoid introducing bit errors. Do not change the position of the switch while the tester is connected to the line.

## Battery Charging Switch (Optional)

**AuroraPlus** can be powered from an external charger or from an internal rechargeable battery in both ISDN and Analogue modes. The two switch positions are:

**BAT** Power is supplied from the internal rechargeable battery, even when the charger is connected.

**CHARGE** The internal battery is charged if the charger is connected. If the charger is not connected, setting the slide switch to the **CHARGE** position acts as an off switch.

Charging is indicated by the red charging LED, next to the charger connection socket. The LED flashes when the charging process is completed.

### Battery Low Warning

When the remaining battery charge drops to 30 minutes, an audible signal is sounded and a warning is displayed on the screen. This screen is redisplayed every 30 seconds. If the battery level drops still further, before it fails completely, the unit switches itself off. It cannot be switched on again until the external charger is connected.

## Termination Resistor Switch (TERM)

Correct operation of the S-bus connection (Point-to-Point or Point-to-Multipoint) can depend on the customer wiring being correctly terminated. The wiring must be terminated with 100 ohms at either end of the S-bus connection in both directions, i.e. Transmit (Tx) and Receive (Rx).



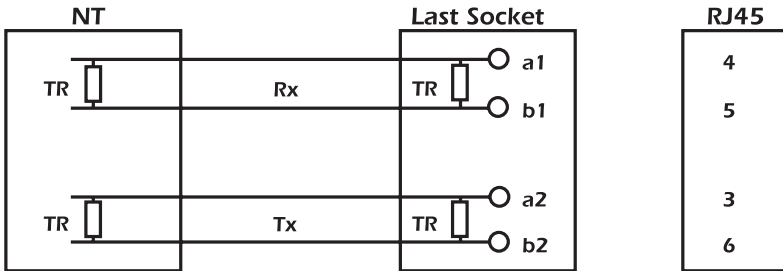

**S bus correctly terminated**

If there are no resistors in the wiring the termination can be achieved with **AuroraPlus**. Set the Termination Resistor Switch as follows.

**DOWN** Additional termination resistors are connected on the line.

**UP** There is no termination by **AuroraPlus**.

If the *TERM* switch is depressed while in POTS Check mode the unit draws analogue dial-tone.

For use of this function, refer to the section titled *POTS Check Switch* earlier in this chapter.

## Interface Switch (Optional)

The Interface Switch is used to select either the ISDN or Analogue interface.

**ISDN** Selects ISDN mode. **AuroraPlus** may be connected to the S or U Interface.

**ANALOG/  
POTS** Selects Analogue mode. The two-wire cable may be connected to the telephone network.



**Note**

If you change the setting of the Interface Switch, you must switch **AuroraPlus** off and on again to apply this change.

## Communication Ports & Connectors

**AuroraPlus**'s communications ports and connectors are located on the bottom of the unit, as shown in the following diagram:

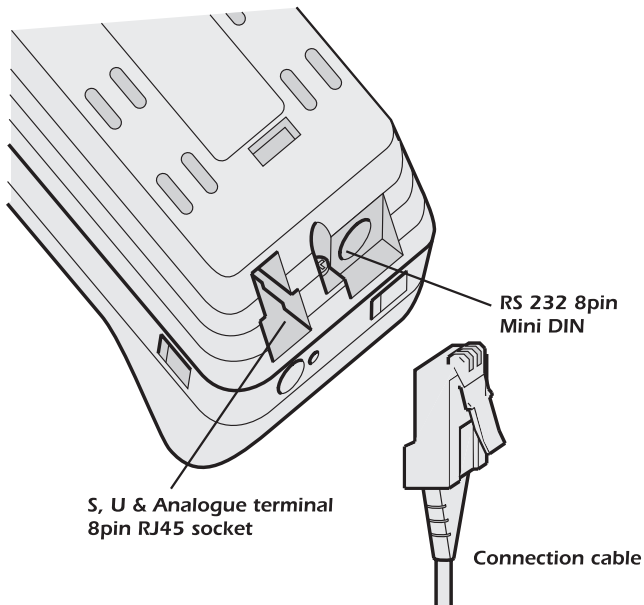

## Connecting AuroraPlus

**AuroraPlus** can connect to the ISDN for Basic Rate testing on the S or U interface, and can also be used for analogue (POTS) testing.



### Caution

When connecting to any interface, remember that high voltages may be present on telecommunications lines.

### Connections for testing

Plug the interface cable into the connector on **AuroraPlus**. The cables are identified as follows:

- S interface: a black, 4-way cable with an RJ45 plug at each end.
- U interface or analogue (POTS): a white, 2-way cable with an RJ45 plug at one end.

Connect the other end of the cable to the equipment under test.

- S interface: You can connect the cable either way round. Plug one end into the unit and the other into an S interface socket on the CPE side of the NT. This can be a single connection or one connection on a 'bus' of up to eight sockets.
- U interface: Connect the cable on the exchange or CO side of the NT, with the NT disconnected.
- Analogue (POTS): connect to a 2-wire line from the exchange or PBX extension.

The following diagram shows the points on the ISDN where you can connect and test using **AuroraPlus**:

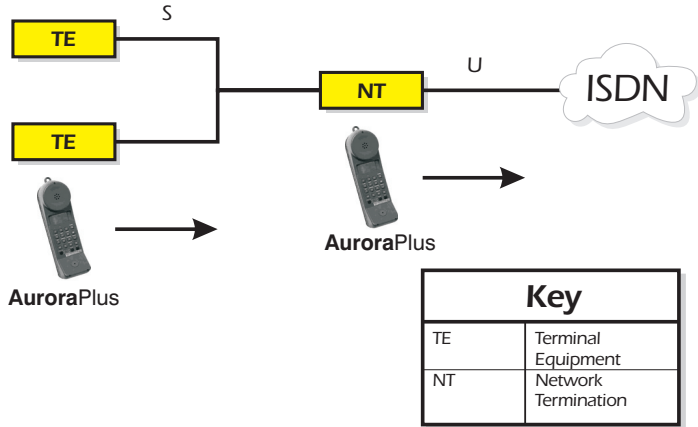

**Note**

When connecting to the U interface, **AuroraPlus** may take a few minutes to initialise before you can begin testing. During this process the screen displays a message telling you that the U interface is initialising.

The following diagram shows how to connect **AuroraPlus** for analogue (POTS) testing:

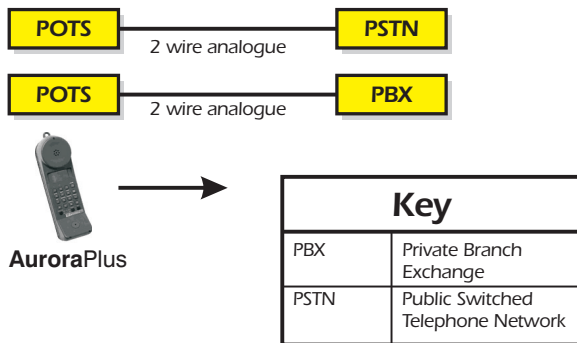

## Connecting to a PC

You would connect **AuroraPlus** to a PC to send test results or protocol information to a PC file for analysis using Trend **AuroraExpert** for Windows, or to download new software using the TrendSend File Transfer Utility.

Using the serial cable, connect **AuroraPlus**'s serial port to the serial port on the PC.

## Switching Power On

If **AuroraPlus** is connected to a powered interface, it will power up automatically.

If you are using an **AuroraPlus** with a built-in battery, slide the **CHARGE/BAT** Switch, on the side of the unit, to the **BAT** position to obtain power from the internal battery.

Alternatively, slide the switch to the **CHARGE** position and connect to the external power supply to charge the battery.

At power-on **AuroraPlus** performs a Self Test and displays an opening screen. This tells you about the model, generation and software version in use.



Press **ENTER** to exit the Opening screen and display the Idle screen (the Idle screen is automatically displayed after 5 seconds have elapsed).

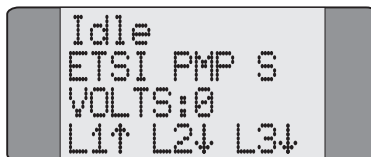

This screen displays the current protocol, line type and interface settings and any voltage detected on the line. The bottom line indicates the layer status.



**Tip**

You can switch the backlight on the display on and off using:



## Displaying the Main Menu



Press the *ENTER* key when the Idle screen is displayed. The Main Menu is displayed:

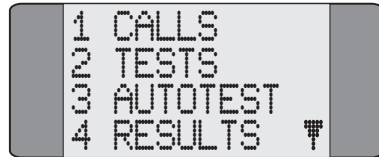

## Scrolling through Menu Pages

Menus which span over more than one page are indicated by a down arrow symbol. For example, the Main Menu spans over two pages:

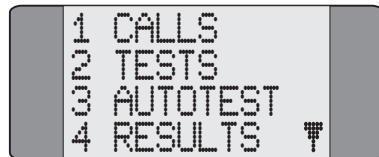

- ▼ To display the second page, press the *SCROLL* key:



- ▼ Press *SCROLL* again to toggle back to the first page.

## Selecting Menu Options

Each menu option has a number associated with it. To choose an option, use the keypad to input the number associated with it. For example, to choose **CALLS** from the Main Menu, press *1*.

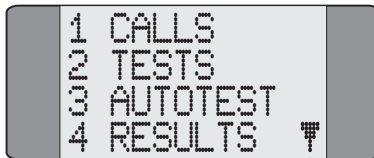

### Note

If you are selecting a service type, a two digit number is required, e.g. '01' to select **TEL-ISDN** (speech with telephony HLC).

**AuroraPlus** uses an asterisk (\*) symbol to identify current settings. For example, in the following Line Type screen **PMP** is selected.





Press *ENTER* to apply the current selection or input the number of an alternative option and press *ENTER* to confirm it.



### Tip

Appendix 3 contains menutree diagrams to help you navigate through the menu structure.

## Exiting from a Menu



To exit from a screen press the *CLEAR* key. You return to the previous screen.

## Returning to the Main Menu

You can return 'home' to the Main Menu from any screen using:

























## Using Hot Keys

Hot Keys let you access **AuroraPlus**'s functions quickly, without having to navigate through the menu structure.

To use a Hot Key, press the *SHIFT* key followed by the number key associated with the function. When you press *SHIFT* an 'S' appears on the screen to indicate you are about to trigger a Hot Key. For example, to access the Loop options press + .



The Hot Keys are as follows:

-  +  Displays information on the last or current call on the selected B channel
-  +  Switches the backlight on and off
-  +  Switches the loudspeaker on or off
-  +  B Channel selection
-  +  Select BER test
-  +  Loop options
-  +  X.25 Test
-  +  Service Check
-  +  Line Configuration Check
-  +  **AuroraPlus** configuration and line voltage
-  +  Returns 'home' to the Main Menu

The Hot Keys are printed in yellow text on the keypad.

The Hot Key combinations are clearly marked throughout this guide using a special symbol. For example:





# Setting Up your AuroraPlus

This chapter tells you how to set up **AuroraPlus** ready for testing. The setup parameters you enter are stored in the unit's EEPROM and are retained if the battery or external power supply fails.

## Displaying the Setup menus

From the Main menu, choose **SETUP**:

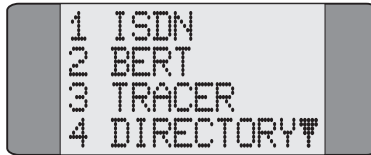

Use the *SCROLL* key to display the second page of Setup options.

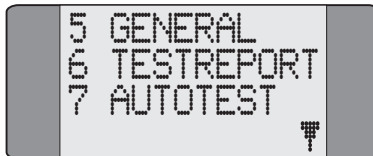

## Selecting Protocol & Line Type

This section describes how to select a different protocol or line type.

Choose **ISDN** from the **Setup** menu to display the following screen:

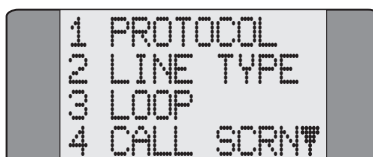

Choose the **PROTOCOL** option.



The list of protocols displayed may vary, depending on the software loaded on your **AuroraPlus**.

## Changing the Protocol

Choose the required protocol. An asterisk (\*) symbol is displayed against the current selection. The above example shows the selection of the ETSI protocol.



Press the *ENTER* key to confirm your choice.

## Changing the Line Type

Choose **LINE TYPE** from the **ISDN SetUP** menu to change the connection type. The following screen is displayed:



Choose the appropriate line type - either Point-to-Multipoint (**PMP**) or Point-to-Point (**PP**). An asterisk (\*) symbol is displayed against the current selection.



Press the *ENTER* key to confirm your choice.



### Note

**LINE TYPE** is part of the layer 2 configuration of the connection. PMP is the same as 'S' reference point operation and PP is the same as 'T' reference point operation.

**Tip**

You can check **AuroraPlus**'s current protocol and bus configuration by performing a Status Check - please refer to *Checking AuroraPlus's Status* in Chapter 5 for details.

## Setting up a Loop

You can set up **AuroraPlus** to provide a loop on incoming calls so that it can be used with another device for BER Testing.

If you make a self-call, **AuroraPlus** automatically loops the call back on the other B-Channel.

The Loop options are as follows:

- **AUTO:** Call Screening is operational, irrespective of the service type. Please refer to *Call Screening* in this chapter for further details. Successfully screened incoming calls are answered automatically and a loop connected. Use this setting for voice or data calls when you wish to perform a looped-back BER Test with a remote device. Note that the unit may be left unattended in this mode. Connect the charger unless **AuroraPlus** is line powered.
- **MANUAL:** Incoming calls are answered manually and then a loop is connected. Use this setting for voice or data calls when you wish to perform a looped-back BER Test with a remote device. Service Checking for outgoing calls operates normally. Call Screening can only be used with voice (i.e. speech or 3k1). Screening only operates if you selected **TELCHK** from the **CALLS** menu.

- **OFF:** Incoming calls are answered manually and then connected to the microphone and earpiece. This setting is normally used for voice calls. Service Checking for outgoing calls operates normally, but Call Screening can only be used with voice calls (i.e. speech or 3k1). Screening only operates if you selected **TELCHK** from the **CALLS** menu.

## Changing the Loop Options



Choose **ISDN** from the **Setup** menu to display the following screen:

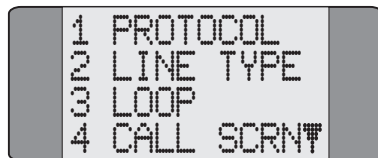

Choose **LOOP**. The loop options are displayed.



Choose the appropriate option. An asterisk (\*) symbol is displayed against the current selection. The above example shows **OFF** selected.



Press **ENTER** to save your selection. You return to the previous screen.

## Call Screening

**AuroraPlus** lets you set screening options for incoming calls.

When enabled, screening allows only incoming calls with a specified Called Party Number (CPN) or Calling Line Identity (CLI). You can store one CPN and one CLI number for Call Screening.

For example, if your number is 123456 you may wish to enter a **CPN SCR** of **12345**. This ensures that only incoming calls with these first five digits are accepted.

Choose **ISDN** from the **Setup** menu.

Select **CALL SCR**.

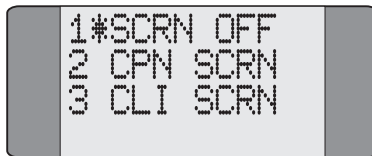

Choose either **CPN SCR** or **CLI SCR**. An asterisk is displayed against your last selection.

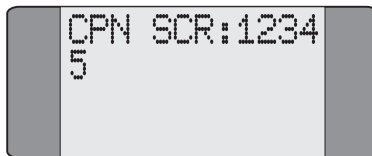

Input the new number (this overwrites any existing values) and press **ENTER** to save it.

To disable Call Screening, choose **SCRN OFF**.



### Notes



- To erase one digit at a time press the *CLEAR* key.
- To append a Sub-address to the CPN or CLI, add a slash symbol (/) by pressing + followed by the Sub-address.

## Address Setup: Setting CPN Sub-address & CLI

Three types of addresses can be stored in **AuroraPlus**:

- your own Calling Line Identification (CLI) number. ISDN lines using the ETSI protocol may be addressed with several different subscriber numbers. On Point-to-Multipoint lines this feature is called MSN (Multiple Subscriber Number). The numbers are referred to as MSN1, MSN2 etc. On Point-to-Point lines this feature is called DDI (Direct Dialling Inward).
- your own Sub-address — Calling Party Sub-address (CLI-SUB)
- a Called Party Sub-address (CPN-SUB)

These addresses can be stored in addition to outgoing directory numbers for speed dialling.

**AuroraPlus** sends CLI and CLI-SUB in the outgoing SETUP message to the switching system to identify itself.

The Called Party Sub-address (CPN-SUB) is included in an outgoing SETUP message only if En Bloc dialling is used.

Choose **ISDN** from the **Setup** menu.



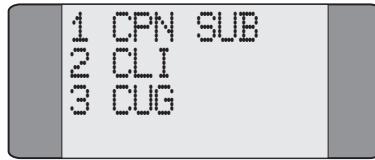

Press *SCROLL*, then choose **ADDRESS** to display the following screen:



Select the appropriate option. An address entry screen is displayed, depending on your selection.

### Inputting a CPN Sub-address or CLI

Enter or overwrite the number you want to store. This number may be up to 19 digits in length.

You can enter CPN Sub-address and CLI Sub-addresses. Sub-addresses are separated from the main number by a slash (/) symbol. This symbol is produced by pressing *SHIFT*+asterisk (\*) -  + .



Press the *ENTER* key. **AuroraPlus** saves the number and returns to the previous menu.



### Notes



- To clear a previously stored number, press the *CLEAR* key to erase one digit at a time.

## Address Setup: Setting CLI Presentation/Restriction

Calling Line ID Presentation (CLIP) enables a subscriber receiving a call to display the caller's ISDN number. The service operates even when the subscriber's line is busy.

Calling Line ID Restriction (CLIR) allows a subscriber making a call to choose whether or not their ISDN number is presented to the person they are calling.

Choose **ISDN** from the **SETUP** menu.



Press **SCROLL**, then choose **ADDRESS** to display the following screen.

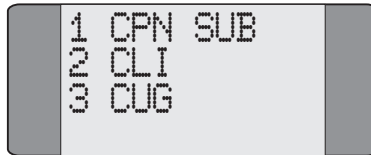

Choose **CLI**.

A screen similar to the following is displayed.

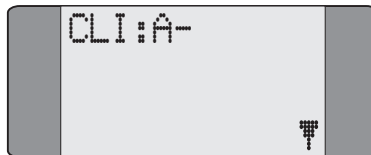

Press **SCROLL**, to display the following Presentation Indication options. You can enter up to 20 digits in each option.

- **Not Present.** Removes the Presentation Indicator from the CLI information element.
- A** **Presentation Allowed.** Allows presentation of the CLI or COL to the called party.
- R** **Presentation Restricted.** Does not allow presentation of the CLI or COL to the called party.
- I** **Interworking.** Enables you to confirm that the remote terminal does not display the CLI when the call is routed through two noncompliant networks.

**U** *Reserved.* Included for future development.



Press **ENTER** () to confirm your choice.

## Setting up a **CUG (Closed User Group)** ETSI

A Closed User Group is a group of subscribers on a network that are configured so that calls to and from the group can be restricted.

Choose **ISDN** from the **SETUP** menu.



Press **SCROLL**, then choose **ADDRESS** to display the following screen.



Choose **CUG** to display the following screen.

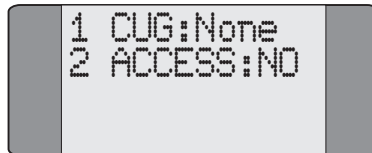

Choose **CUG**.

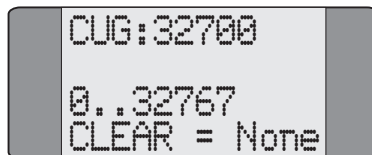

Enter the **CUG** you want to use.

To delete digits one at a time, press **CLEAR**. If you want to enter a new CUG, enter the first digit to delete the current CUG.

### Setting up the CUG Access restrictions

This option enables you to set up whether you want to be able to make calls outside the CUG, or restrict the calls to inside the CUG.

From the **CUG** screen choose **ACCESS**.



Choose **YES** to allow calls to be made outside the CUG.

Choose **NO** to restrict calls to within the CUG.

## Setting the BER Test Length

The BER (Bit Error Rate) Test is used to check the integrity of an ISDN line. A call may be made to the number of the other B Channel on the calling unit, a loopback box or to another remote tester.

When you are performing a BER test you can make a self-call, **AuroraPlus** then automatically loops the call back on the other B-Channel.

If two **AuroraPlus** units are connected, and if the Loop option is set to **OFF**, the call may be turned into a two-way BER Test by answering the call in the BERT menu. Note that if you do this the BER test that finishes last will have logged more errors than the test that finished first.

The call uses the currently selected service. The BER Test is performed using a 2047 bit Pseudo Random pattern according to ITU G.821/O.152.



**Note**

Your settings will also apply to the fixed link BERT. For more information, see *Testing Fixed Links* in Chapter 5.

Choose **BERT** from the **Setup** menu to display a list of preset durations.

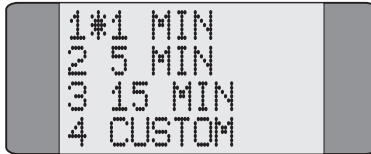

You can select from the following durations - **1 MIN**, **5 MIN** or **30 MIN**. An asterisk (\*) is displayed next to the current selection. The default duration is 5 minutes.



You can select from the following durations - **1 MIN**, **5 MIN** or **15 MIN**. An asterisk (\*) is displayed next to the current selection. The default duration is 1 minute.



Press the **ENTER** key to confirm your choice. **AuroraPlus** returns to the previous menu.

To specify a different duration for the BER Test, choose **CUSTOM**. This displays the following screen:

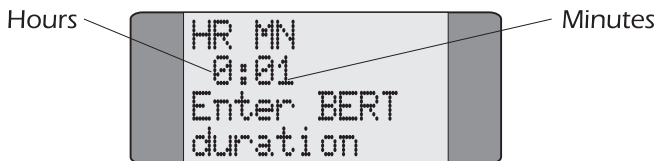



Specify the duration of the BERT, using the number keys to enter the time in hours and minutes, and then press *ENTER*.

For a continuous BER Test, enter a value of zeroes.



**Note**

The maximum length of time you can define for a custom BERT is 3hrs 59min.

## Tracer Setup

The Tracer is the name given to the function which lets you capture ISDN signalling information from the D (Demand) Channel during an attempted or established call. This information is sometimes called 'Decode'.

The stored information is held in **AuroraPlus**'s memory. **AuroraPlus** lets you review the stored data on screen or download it to a PC for analysis. You can also clear the data from memory. The following section describes the capture of decode to memory. You can store up to 99 lines of decode in **AuroraPlus**'s memory.

Select **TRACER** from the **Setup** menu.



### Turning the Tracer On and Off

Choose **ON** to start capturing data; choose **OFF** to stop data capture. An asterisk (\*) symbol is displayed next to the current selection.



Press the *ENTER* key to confirm your choice.

After turning the Tracer on, continue with normal operation (making calls etc.) **AuroraPlus** captures data until the memory becomes full and **Buffer Full** is displayed.



Press **CLEAR** to exit the Buffer Full Screen.

You can download the trace to a PC running the Trend **AuroraExpert** for Windows data analysis package. For information on downloading the tracer memory to a PC, see *Displaying Tracer Output* in Chapter 5.

## Entering the Date and Time



### Note

If you switch off **AuroraPlus** the date and time is not updated while it is switched off, it remains the same as when you switched it off. The date and time will be lost if the battery or external power supply fails.

Choose **GENERAL** from the **SETUP** menu.



Choose **DATE/TIME**.

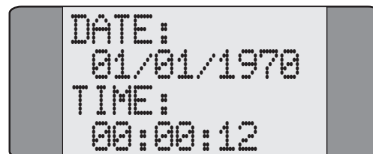

Press **SCROLL** to select **TIME** or **DATE**.

Enter your settings and press **ENTER** to save and return to the **GENERAL** screen.

## Storing Speed Dialling Numbers

Speed Dialling lets you recall and dial previously stored numbers from **AuroraPlus**'s memory. Up to five numbers (numbers 0 to 4) may be stored - these may be numbers you use regularly during testing. For details on how to make calls using Speed Dialling, please refer to *Speed Dialling* in Chapter 4.



### Note

You can only use speed dial numbers when **AuroraPlus** is operating in En-Bloc dialling mode.

Choose **DIRECTORY** from the **General** menu to display the following Speed Dial Screen. By default, **AuroraPlus** displays the contents of the first memory location.

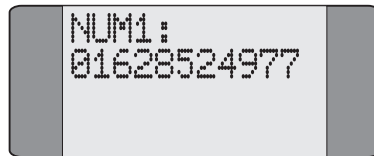

### Displaying a Different Memory Location



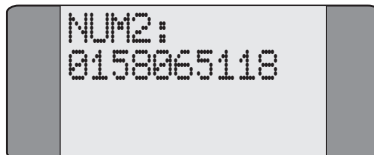

Press the *SHIFT* key followed by the appropriate number key to select a different memory location. For example, to select memory location 2, press *SHIFT* and **2**. The following screen is displayed:





### Entering a Speed Dial Number

If a number is already stored in this location **RECALL** is displayed, together with the number held.

-  To add digits to the end of the existing number press **CLEAR** and enter the new digits.
-  To erase the existing number, digit by digit, repeatedly press the **CLEAR** key.
-  After inputting the number, press **ENTER** to save it. A screen similar to the following is displayed to indicate the number has been stored:

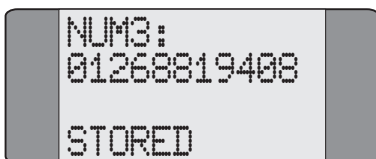

## Changing the Language

**AuroraPlus** is designed to display text in up to four languages. The languages currently available are English, French, Spanish, Italian and German.

Choose **GENERAL** from the **Setup** menu to display a screen similar to the following:

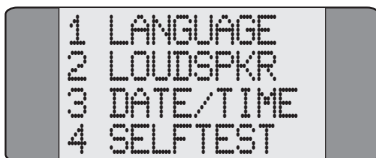

Choose **LANGUAGE** from the **General** menu to display a screen similar to the following:



Select a language from the display. An asterisk (\*) appears next to the current selection.



Press the *ENTER* key to confirm your choice.

## Loudspeaker Volume Settings

**AuroraPlus** contains a loudspeaker built into the top left hand side, next to the earpiece. The level of volume obtainable from the loudspeaker can be set at three levels as follows:

Choose **GENERAL** from the **Setup** menu to display the following screen:

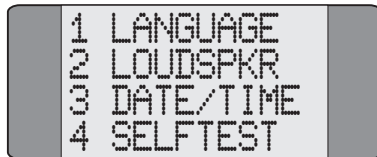

Choose **LOUDSPKR** from the **General** menu to display the following screen :



Choose the required level. An asterisk (\*) appears next to the current selection.



Press the *ENTER* key to confirm your choice.

## Default Settings

The following table shows the factory default settings for **AuroraPlus**. You can reset these defaults using Self Test Facility code '13' - please refer to *Self Test Functions* in Chapter 5 for further information.

Factory Default Settings	
Protocol	ETSI
Bus Configuration	Point to Multipoint (PMP)
Service Type	Telephony (ISDN-TEL)
B Channel	Bx
Encoding	A-law
Calling Line Identity (CLI) (ETSI)	No Entry
EAZ (1TR6)	0
CPN Sub-address	No Entry
Call Redial	No Entry
Speed Dialling	No Entry
Call Screening	Off
CPN Screening	No Entry
CLI Screening	No Entry
EAZ Screening (1TR6)	0
BERT Duration (ETSI) and (1TR6)	1 minute
BERT Duration (TPH)	5 minute



# Call Establishment

# 4

This chapter describes how to make and receive calls using **AuroraPlus**. Also discussed is how to select an ISDN service and bearer channel for calls and how to access the supplementary services options.

## Making a Call

Choose **CALLS** from the Main Menu to display the following screen:

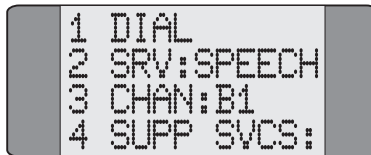

Choose **DIAL** to display a dial screen.

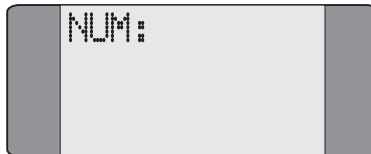

## Dialling

**AuroraPlus** can make calls in either the Overlap or En Bloc dialling mode. En Bloc dialling involves entering the entire number *before* it is sent. With Overlap dialling, digits are sent as they are dialled.

### En Bloc Dialling



Enter the entire number you want to dial and press the **ENTER** (↵) key.



If you make a mistake, press the **CLEAR** key to erase the last digit entered.

### Overlap Dialling



- Press the **ENTER** (↵) key *before* entering the CPN. Note that the screen may display **PROCEEDING**, depending on the network.
- Enter the digits you want to dial.



### Note

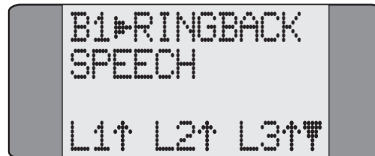

If the call is being established on a fixed link (no protocol), or back to back with another tester it connects before any digits are dialled.

The call is initiated and **AuroraPlus** displays a Call Status screen, similar to the following:



This shows the progress of the call, the number dialled, the status of the layers and any messages received from the network. For a speech call, the call progress tones are present in either the earpiece or the loudspeaker.

When a speech call is connected, to switch on the

loudspeaker press  + . If you make another call without switching off **AuroraPlus** the loudspeaker will be automatically switched on for that call.

### Connected screen & Call Control Options

When the called party lifts the handset the call is connected and a screen similar to the following is displayed:



In the above example, a call has been connected on channel B1.

Once a call is connected, the following options are available: running a BER Test, activating a Loop, or selecting a Supplementary Service. To access these options, press the **SCROLL** key  to see the Call Control Options screen:

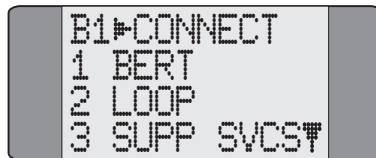

To perform a BER Test, choose **BERT** - the BER Test Status screen is displayed. See *Performing a BER Test* in Chapter 5 for more information.

To activate a Loop, choose **LOOP** - the Loop Activation screen is displayed. See *Setting Up a Loop* in Chapter 3 for more information.

To select a Supplementary Service, choose **SUPP SVCS** - you can choose either the **KEYPAD**, **HOLD**, **SUSPEND**, **UUI**, or **UUS3 SRV 3** options. See *Supplementary Service Selection* later in this chapter.

To send DTMF tones, choose **TONES**.



**Note**

Once in the connected state, additional Called Party Number digits are sent in the D Channel each time a number key is pressed. This is necessary to 'dial through' certain PBX equipment. Some ISDN equipment may not respond correctly to this signalling. When connected to such equipment, be careful not to send digits, which may result in the call entering an indeterminate state.

## DTMF tones

When a call is connected DTMF tones are not sent automatically.

### To send DTMF tones when a call is connected



From the Connect Screen press *SCROLL* to display the following screen.



Choose **TONE**.

Enter the digits you want to send.

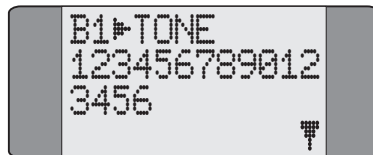



The DTMF tone is sent as you enter each digit. Digits are deleted from the beginning of the display if you enter more than 35 digits. If you continue to add more digits the new digits are added to the end of the display.

If you want to delete all the digits displayed, press **CLEAR**.



Press **SCROLL** and choose **EXIT** to return to the **CONNECT** menu.

## Clearing a Call



Press **ENTER** to clear a call. **AuroraPlus** displays a **Released** (if cleared remotely) or **Cleared** screen similar to the one shown below. This displays the Call Clearing Cause Code, the location and Layer Status information.

```

CLEARED
CAUSE 16
LOCATION 2
L1↓ L2↓ L3↓T
  
```

To display an explanation of the various Cause Codes and locations, press the **SCROLL** key . For further information, see *Appendix 4 Call Clearing Cause Codes*.

```

Normal Call
Clearing
L1↓ L2↓ L3↓T
  
```

## Speed Dialling

Speed dialling only operates in En Bloc dialling mode. Please refer to *Storing Speed Dialling Numbers* in Chapter 3 for information on setting up this facility.

Choose **CALLS/DIAL** from the Main Menu to display a Dial screen.



Press **SHIFT** followed by the number of the memory location containing the CPN you wish to dial. For example, to dial the number held in Speed Dial memory location 1, press + 1. The number is recalled from memory and displayed:

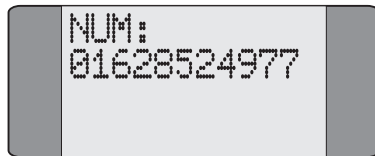



Press **ENTER** () to dial the number.

## Call Redial

This facility lets you automatically redial the last number dialled. The last number dialled is stored in memory after the unit is disconnected from the ISDN for as long as the power is on. Redial operates in En Bloc and Overlap dialling modes.

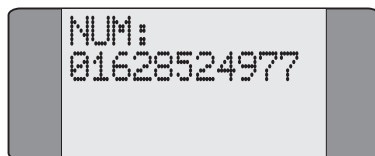
Select **CALLS/DIAL** to display the Dial screen together with the last number dialled.



 Press **ENTER** to automatically redial this number. If you do not want to redial this number, enter a different number; the last number dialled is overwritten.

 To add digits to the end of the last number dialled, press the **CLEAR** key once and enter the new digits.

 To erase the last number dialled, digit by digit, repeatedly press the **CLEAR** key.



### Note

If you alter the service or channel settings, the last number dialled is automatically cleared and Call Redial is not available.

## Answering Incoming Calls

How an incoming call is answered depends on the Loop settings. If the Loop option is set to **AUTO**, **AuroraPlus** automatically answers incoming calls. If it is set to **OFF** or **MANUAL**, you have to answer the call manually. Please refer to *Setting up a Loop* in Chapter 3 for further information.



An incoming call is indicated by the ringer sounding. If it is the only active call it is displayed on the screen immediately.

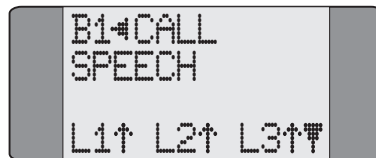

If there are other active calls press **SHIFT + 4** (B Channel selection). A screen similar to the following is displayed:



### Accepting the call

 Press the **ENTER** () key to answer the incoming call.



**Note**

If an incoming call is received when you are in a Setup or Results screen it is automatically rejected by **AuroraPlus**.

## Call Waiting

Call Waiting informs you that there is an incoming call, even when no channel is available to accept it because other calls are in progress. **AuroraPlus** beeps to indicate Call Waiting - you can either accept or reject the waiting call.

## Dealing with a Second Call

Call Waiting depends on the Loop settings. If the Loop option is set to **AUTO** and a B Channel is available, **AuroraPlus** automatically answers any new, incoming calls. If it is set to **OFF** or **MANUAL**, a second incoming call is indicated by a 'beep' in the earpiece or loudspeaker. Please refer to *Setting up a Loop* in Chapter 3 for further information.



**Note**

If an incoming call arrives on the second B Channel during the dialling procedure, the dialling procedure is terminated and the Call Waiting procedure starts.

**CALL WAITING** is displayed on a screen similar to the one shown below. The B Channel, Bearer Service, CLI and Layer Status are also displayed.

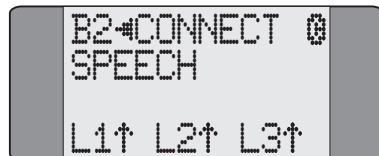

To answer the new call manually you must either clear the original call or place it on hold. For details, refer to *Placing a Call on Hold* and *Clearing a Call*, in this chapter.

### Dealing with a third call

If there is an incoming call when both B Channels are in use you can put one of the other calls on hold while you answer the new incoming call. A new incoming call is indicated by a 'beep' in the earpiece or loudspeaker.

To answer the new incoming call:



Move to the new incoming call by pressing **SHIFT + 4**.

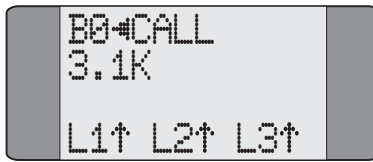

Press the **ENTER** () key to answer the incoming call and put the last active call on hold.

## Placing a Call on Hold

During an existing call, you can either:

- put the current call on hold and make an outgoing call or
- accept a second incoming call.

## Making an Outgoing Call During an Existing Call



Press the **SCROLL** key from the Connected screen to display the Call Control Options screen:

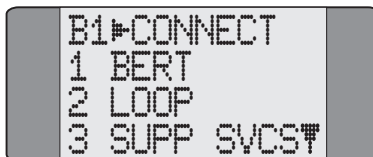

Select **SUPP SVCS**.



Select **HOLD**. This places the current call on hold and **HELD** is displayed in the Call Status screen.



**Note**

If the Call Hold request fails, **REJECT** is displayed. Press **CLEAR** to return to the Connected screen of the established call.



Press **SCROLL** to display further options:



Choose **NEW CALL** to make a new, outgoing call.

### Retrieving the held call



First, press *ENTER* to clear down the second call.



Press *SCROLL* from the Call Status screen of the original call to display further options.

Choose **RETRIEVE** to recover the held call.

### Accepting an Incoming Call During an Existing Call

If a second call is received, during an existing call, **AuroraPlus** beeps to indicate there is a call waiting. You can place the current call on hold and answer the second call.



Press *SCROLL* to display the Call Control Options. Choose **SUPP SVCS/HOLD** - the existing call is placed on hold.



**AuroraPlus** rings to indicate the second call. Press *SHIFT + 4* to display the Call Status screen for this call.





To answer the second call, press **ENTER** (↵). The call is connected.



### Retrieving the held call



First, press **ENTER** to clear down the second call.



Press **SHIFT + 4** to display the Call Status screen for the held call.



Press **SCROLL** to display further options.

Choose **RETRIEVE** to recover the held call.



### Tip

To toggle between the Call Status screens for each call, press **SHIFT** and **4**. The Call Status screen displays the channel and CLI for each call.

## Selecting an ISDN Service

This section describes how to select the teleservice capability and service for any outgoing calls that you make.



Choose **CALLS** from the Main Menu to display the following screen:

```

1 DIAL
2 SRV: SPEECH
3 CHAN: B1
4 SUPP SVCS:
  
```

**SRV:** shows the currently selected service. In the above example, **SPEECH** has been chosen.

To change the service type, select **SRV:**. The following screen is the first of a set showing the services available:

```

01* TEL-ISDN
02 3_1K AUD
03 DATA 64
04 FAX GRP3T
  
```

An asterisk (\*) is displayed against the currently selected service.



Press the **SCROLL** key repeatedly to scroll through the service screens.

To choose a service, input the number which corresponds to it - for example, input **01** to select **TEL-ISDN**. The service is selected and **AuroraPlus** displays the previous menu showing the selected service type.



### Notes

- You do not have to display the screen containing the option you wish to select. Simply input the number associated with it. For example, you may have options 01 to 04 displayed, but you can input and select 15 from this screen.

- You must input two digits when selecting a service type. For example, *01* for **TEL-ISDN**.

## Setting up a User-Defined Bearer Service



The user-defined Bearer Service enables you to define the Bearer Capability, Low Layer Capability and High Level Capability information elements sent in the SETUP message at the start of a call.

To set up the Bearer Service:

Choose **CALLS** from the main menu to display the following screen:



Choose **SRV** to display a screen similar to the following screen.

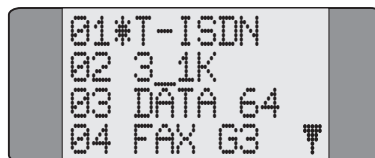

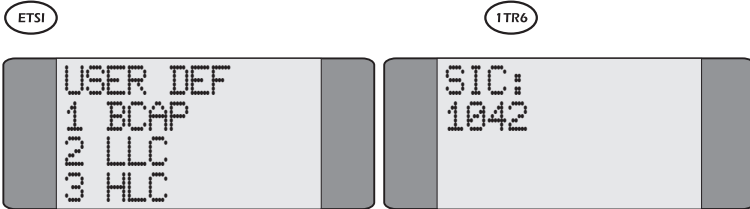

Press *SCROLL* to display more options and choose **USER** to display the following screen.

**Tip**

**AuroraPlus** stores the last option you selected.

## Entering Hexadecimal Numbers

The Bearer Capability, Low Level Compatibility and High Level Compatibility settings must be entered as hexadecimal numbers. To enter the settings you want:

To enter the digits **1** to **9**, press the appropriate keys.

To enter the digits **A** to **C**:

Repeatedly press **2** until the character you want is displayed.

To enter the digits **D** to **F**:

Repeatedly press **3** until the character you want is displayed.



To move the cursor to enter the next character press *SCROLL*.

## Setting the Bearer Capability ETSI

Choose **BCAP** to display the following screen.

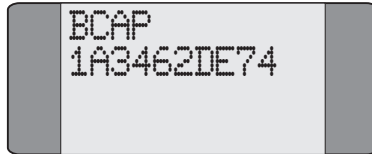

Enter the setting as described in *Entering Hexadecimal Numbers*.

You can enter up to 11 bytes (22 characters).

You must enter an even number of characters.



Press **ENTER** () to confirm your choice.

## Setting the Low Layer Capability ETSI

Choose **LLC** to display the following screen.

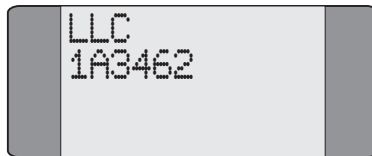

Enter the setting as described in *Entering Hexadecimal Numbers*.

You can enter up to 14 bytes (28 characters).

You must enter an even number of characters.



Press **ENTER** () to confirm your choice.

## Setting the High Layer Capability ETSI

Choose **HLC** to display the following screen.



Enter the setting as described in *Entering Hexadecimal Numbers*.

You can enter up to 3 bytes (6 characters).

You must enter an even number of characters.



Press **ENTER** ( $\sigma^{\downarrow}$ ) to confirm your choice.

## Setting the Bearer Service 1TR6

On the User Defined Bearer Capability screen, enter the setting as described in *Entering Hexadecimal Numbers*.

You can enter up to 2 bytes (4 characters).

You must enter an even number of characters.

From the **SRV** screen choose **USER** to display the following screen.

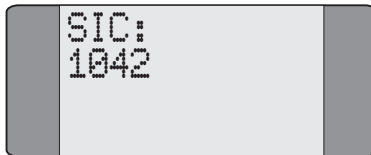

Press **ENTER** ( $\sigma^{\downarrow}$ ) to confirm your choice.

## Channel Setup

The ISDN Basic Rate Interface provides for two B Channels (Bearer Channels) and one D Channel (Demand Channel). Each multiplexed Bearer Channel can carry either voice or data information. During setup, you should define the default channel to make outgoing calls with as B1, B2 or BX. The D Channel is a fixed physical link and is not definable.

The three channels are:

- B1 (Bearer Channel 1)
- B2 (Bearer Channel 2)
- BX (either Bearer Channel)

The type of services that each channel supports can also be defined individually. For example, B1 can be set up for voice communication, and B2 for fax. Where the channel or service cannot be defined in advance (for example, a cleared call on B1 with a maintained call on B2 when a subsequent incoming call is received) then BX can be used to automatically find the free channel.



### Note

Some switches or PBXs do not allow the TE to 'demand' a B Channel. The TE can only request a channel Bx.

Choose **CALLS** from the Main Menu to display the following screen:

```
1 DIAL
2 SRV: SPEECH
3 CHAN: B1
4 SUPP SVCS:
```

**CHAN:** displays the currently selected channel - in the above example Channel B1 has been chosen.

Choose **CHAN:** to change the currently selected channel. The following screen is displayed:



Select the appropriate channel - **B1**, **B2**, **BX** or **D**. An asterisk (\*) is displayed against the current selection. The previous screen is displayed showing the channel selected.

## Supplementary Service Selection

Supplementary Services are additional ISDN services to which users can subscribe. They supplement the functions of Bearer Services or Teleservices.

The available supplementary services are:

- Call Forwarding
- Call Hold and Retrieve
- Call Deflection
- Keypad
- Three Party Call
- MCID
- CCBS
- User-to-user signalling
- Call suspend/resume

### Call Forwarding

Call Forwarding is a service which lets you send future incoming calls to another number instead of to your number.

**AuroraPlus** can be used to activate and deactivate Call Forwarding, where this facility is supported by the network.

Call Forwarding is protocol specific.

#### Types of Call Forwarding

- CFU (Call Forwarding Unconditional). This enables a call to be forwarded regardless of the line status.
- CFB (Call Forwarding when Busy). This enables a call to be forwarded when the line is in use.
- CFNR (Call Forwarding on No Reply). This only forwards a call when the call is not answered.

Call Forwarding types may be applied individually to each type of ISDN service or to all services. Call Forwarding is also programmed individually for each CLI on a Point-to-Multipoint configuration and for the whole interface on a Point-to-Point configuration.



### Types of Call Forwarding <sup>(1TR6)</sup>

- AWS1 (Call Forwarding unconditional).
- AWS2 (Call Forwarding when there is no reply, when the line is busy or when there is no Terminal Equipment or the equipment is out of order).

The call screening on Call Forwarding is typically used where the CPN has auto switched fax equipment and the Call Forward number has not.

### Types of Call Forwarding <sup>(VN)</sup>

Call Forwarding is either Unconditional or No Reply, depending on which service has been subscribed to.

### Accessing Call Forwarding from the Menu

Choose **CALLS** from the Main Menu.

Choose **SUPP SVCS** to display the following Supplementary Service screen:

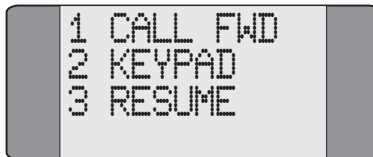

Choose **CALL FWD**. **AuroraPlus** displays either:

- ~~(VN)~~ • a screen for you to choose the Call Forwarding Type
- (VN) • a screen from which you activate/deactivate Call Forwarding.

### Selecting the Call Forwarding Type VN

Choose **CALL FWD** to display the Call Forwarding screen, from which you select the Call Forwarding type. For example:



### Activating Call Forwarding ETSI

Select the Call Forwarding type you wish to activate. The following screen is displayed:

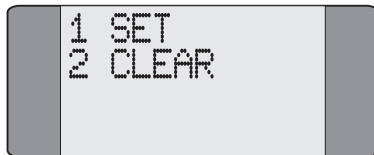

Choose **SET** to activate Call Forwarding. Now select the service type Call Forwarding is to be applied to.



- ▼ Press the *SCROLL* key repeatedly to scroll through the various service types. Enter a two digit service type code. If you choose **ALL SERV** Call Forwarding is applied to all services. A screen similar to the following is displayed:

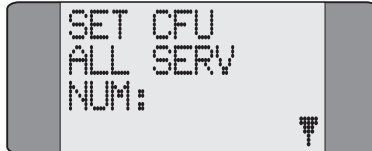

Key in the number to which calls are to be **forwarded**. You can also enter a Sub-Address here - press *SHIFT* and  to insert a Sub-Address delimiter and key in the Sub-Address digits.

- ▼ Press *SCROLL* to display the following screen:



Choose **SEND** to send the Call Forwarding request to the network. **WAIT** is displayed while **AuroraPlus** awaits an acknowledgement from the network. Alternatively, choose **EXIT** to return to the service type selection screens.

### Deactivating Call Forwarding



Choose the type of Call Forwarding you wish to deactivate.  
The following screen is displayed:



Choose **CLEAR**. Now select the service type for which you wish to deactivate Call Forwarding.



- ▼ Press the *SCROLL* key repeatedly to scroll through the various service types. Enter a two digit service type code. If you choose **ALL SERV** Call Forwarding is deactivated on all services. A screen similar to the following is displayed:

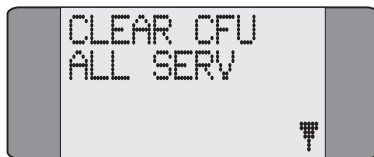

- ▼ Press *SCROLL* to display the **SEND/EXIT** options:

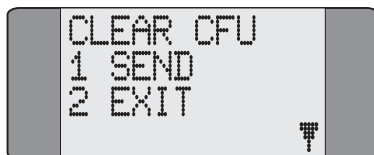

Choose **SEND** to send the Deactivate Call Forwarding request to the network. **WAIT** is displayed while **AuroraPlus** awaits an acknowledgement from the network. Alternatively, choose **EXIT** to return to the service type selection screens.

### Activating Call Forwarding <sup>1TR6</sup>



Select the Call Forwarding type you wish to activate. The following screen is displayed:

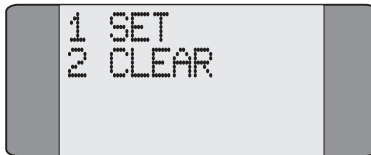

Choose **SET** to activate Call Forwarding. A screen similar to the following is displayed:

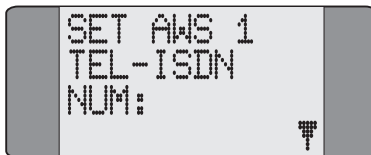

Key in the number to which calls are to be forwarded to.



Press **SCROLL** to display the **SEND/EXIT** options:

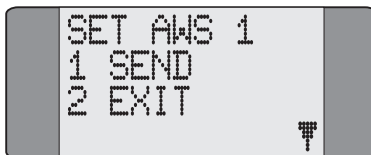

Choose **SEND** to send the Call Forwarding Activation request to the network. **WAIT** is displayed while **AuroraPlus** awaits an acknowledgement. Alternatively, choose **EXIT** to return to the previous **Set/Clear** options.

### Deactivating Call Forwarding 1TR6



Choose the type of Call Forwarding you wish to deactivate. The following screen is displayed:

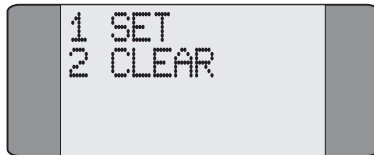

Choose **CLEAR**. A screen similar to the following is displayed:



Press **SCROLL** to display the **SEND/EXIT** options:



Choose **SEND** to send the Deactivate Call Forwarding request to the network. **WAIT** is displayed while **AuroraPlus** awaits an acknowledgement from the network. Alternatively, choose **EXIT** to return to the previous **Set/Clear** options.



### Tip

To display Call Forwarding settings on the line, refer to *Performing a Status Request* in Chapter 5.

### Activating Call Forwarding <sup>VN</sup>

When you select Call Forwarding, **AuroraPlus** displays the following screen:



Choose **SET** to activate Call Forwarding—the type of call forwarding depends on which service has been subscribed to. A screen is displayed for you to enter the number to which calls are to be forwarded.

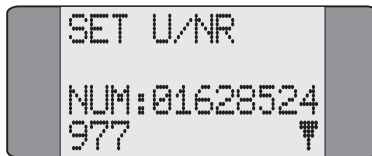

Type the forwarded-to number.



Press **SCROLL** to display the **SEND/EXIT** options:

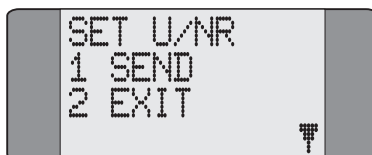

Choose **SEND** to send the Call Forwarding request to the network. **WAIT** is displayed while **AuroraPlus** awaits an acknowledgement from the network. Alternatively, choose **EXIT** to return to the **SET/CLEAR** options.

### Deactivating Call Forwarding <sup>VN</sup>

When you select Call Forwarding, **AuroraPlus** displays the following screen:



Choose **CLEAR** to deactivate Call Forwarding—the type of call forwarding depends on which service has been subscribed to. A screen similar to the following is displayed:

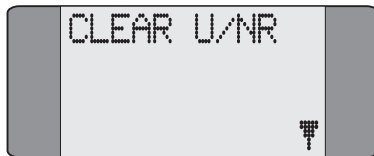

Press **SCROLL** to display the **SEND/EXIT** options:

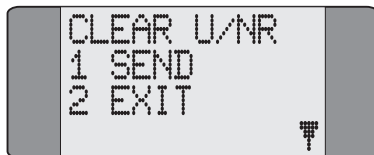

Choose **SEND** to send the Deactivate Call Forwarding request to the network. **WAIT** is displayed while **AuroraPlus** awaits an acknowledgement from the network. Alternatively, choose **EXIT** to return to the **SET/CLEAR** options.



## Call Deflection

Call Deflection enables a user receiving an incoming call to send the call to another number. Call Deflection can only be performed when a call is received, unlike Call Forwarding that is set up in advance.

When an incoming call is presented:



Press *SCROLL*.

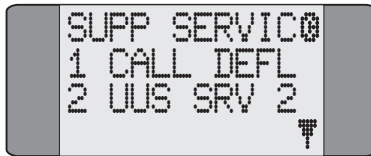

Choose **CALL DEFL**.

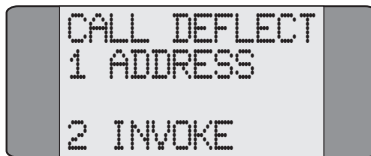

To choose the number you want to transfer the call to, choose **ADDRESS**, then enter the number (up to 19 digits).



**Tip**

To return to the previous screen, press *CLEAR*.

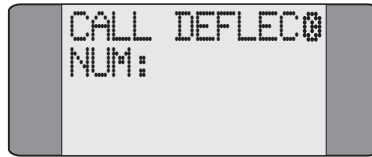

Press *ENTER* () to return to the previous screen.

To invoke Call Deflection, choose **INVOKE**, the following screen is displayed.

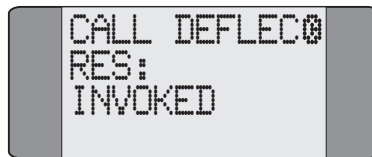

If the Call Deflection is successful, the following screen is displayed:

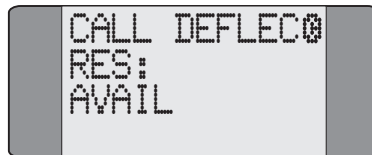

## Keypad Facility ETSI

The Keypad facility enables you to send requests to the network to initiate and test the operation of 'Stimulus' controlled Supplementary Services. The Keypad facility can be used either with or without an active, established call.

## Accessing the Keypad without an Active Call Established

Choose **CALLS** from the Main Menu.

Choose **SUPP SVCS** to display the following Supplementary Services screen.

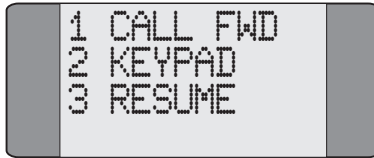

Choose **KEYPAD**.



Choose the dialling mode you want to use.

If you choose **EN-BLOC**, the characters are sent in a block when you press the *ENTER* (↵) key; if you choose **OVERLAP**, the characters are sent as you press the keys.



### Notes on entering Keypad Codes

If the characters you enter start with **#** or **\***, and end with **#**, they are sent in a keypad facility information element.

For example if you enter **\*21\*6489#**, it will be sent in a keypad facility information element.

If you enter characters after the #, they are sent as a Called Party Number information element.

For example if you enter \*01\*6489#90698, then \*01\*6489# is sent in a keypad facility information element, and 90698 is sent in the Called Party Number information element.

If the characters you enter start with a number, they will be sent in a Called Party Number information element.

### En-bloc dialling

When you are using en-bloc dialling you must enter the characters before you can go off-hook.

Enter the Keypad code (refer to the appropriate Reference Guide for your network's Supplementary Service codes).

The characters are displayed on the screen as you enter them:



Press the **ENTER** (↵) key.

The characters are sent.



To send another string, press **CLEAR**.

This returns you to the entry screen.

For information on how to send a Keypad code when a call is active, see *Accessing the Keypad during an Active Call*.

**KP SENT** is displayed and **AuroraPlus** waits for an acknowledgement from the network.

Typically, the reply from the network occupies a single screen, but may be displayed in a series of overflow screens.



Press **SCROLL** to scroll up through the reply,

OR



**SHIFT+SCROLL** to scroll down through the reply.



If no response is received from the network, the transmitted Keypad string continues to be displayed.

### Overlap dialling

From the **Keypad** screen choose **Overlap**.

Enter the Keypad code (refer to the appropriate Reference Guide for your network's Supplementary Service codes).



Press **ENTER** (.

The characters are sent as you press the keys.

Typically, the reply from the network occupies a single screen, but may be displayed in a series of overflow screens.

For information on how to send a Keypad code when a call is active, see *Accessing the Keypad during an Active Call*.



Press **SCROLL** to scroll up through the reply,

OR



**SHIFT+SCROLL** to scroll down through the reply.



If no response is received from the network, the transmitted Keypad string continues to be displayed.

### **Accessing the Keypad during an Active Call**



During an established call, press **SCROLL** to display the Call Control options:

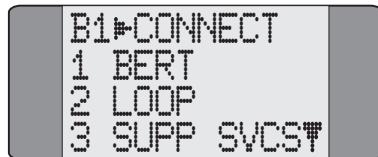

Choose **SUPP SVCS**.

Choose **KEYPAD**.

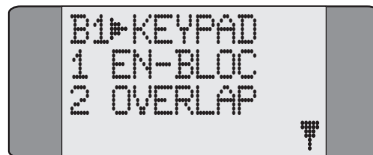

Choose the dialling mode you want to use.

If you choose **EN-BLOC**, the characters are sent in a block when you choose **SEND**; if you choose **OVERLAP**, the characters are sent as you press the keys.



Enter an information string (refer to the appropriate Reference Guide for your network's Supplementary Service codes).



If you chose en-bloc dialling, to send the characters press **SCROLL** to display the following screen:



### Tip

To toggle between the **KEYPAD** screen and the **Send/Exit** screen, press **SCROLL**.

Choose **SEND** to transmit the information string. A screen similar to the following is displayed until a response is received from the network.



The network response is displayed:

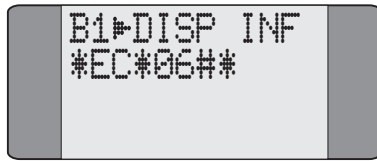

To send another string, press **CLEAR**. This returns you to the entry screen.

To exit, first press **CLEAR** to return to the **String** screen. Press the **SCROLL** key to display the **Send/EXIT** options and choose **EXIT**.



**Note**

If no string is entered, the **SEND** option is not available.

## Malicious Call Identification (MCID)

This service allows you to request that the source of an incoming call is identified and registered by the network. You can specify whether you want to activate MCID during a call or at the end of a call.

Choose **SETUP** from the Main Menu.

Choose **ISDN**.

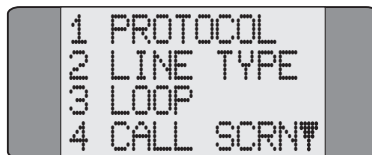





Press *SCROLL* to display the **SUPP SVCS** option.

Choose **SUPP SVCS** to display the following screen:



Choose **MCID** to display the following screen:



Choose **DURING** to activate MCID during a call or select **END** to activate it at the end of calls. Choose **OFF** to deactivate MCID. An asterisk (\*) indicates the current selection.

## Making a Three Party Call

This service allows you to participate in and control a three-way conversation.

This feature is only available on Point-to-Multipoint connections, when two or more calls are connected on a single Bearer Channel.

After you have established two calls, and placed one of the calls on hold, you can set up a Three Party Call (please refer to the section entitled *Placing a Call on Hold* in this chapter for further information).

For example, in the following diagram, a call has been established with Steve and placed on hold. A second call has then been established with Nick.

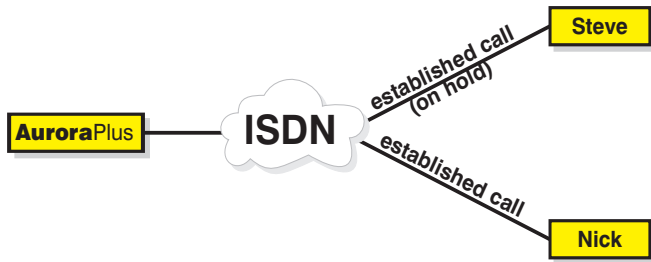

The Third Party option removes the On-Hold status from the first call allowing all three parties to communicate.



When you have two calls established (one of which is on-hold), press *SCROLL* from the Connected screen to display the **SUPP SVCS** option.

Choose the SUPPSVCS option, the following screen is displayed:



Choose **3PARTY** to send a Three Party request to the network. A screen similar to the following is displayed (sometimes only for a split second):

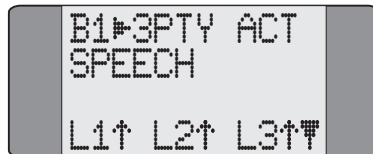

When the network responds, the On-Hold status is removed and the Three Party Call established. If there is no response from the network a Timeout or Reject message is displayed.



**Note**



If you press *SHIFT* + 4 the Call Status screen of the held call is displayed as:



**Clearing Down a Three Party Call**

You can end a Three Party Call by clearing either one of the calls. In the following example the second call is cleared.

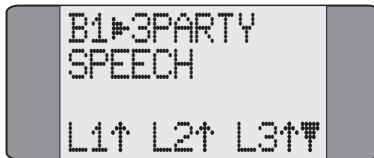

Press *SCROLL* to display the **3PARTY OFF** option.

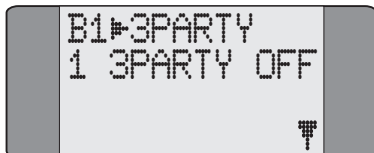

Choose **3PARTY OFF** to clear the call.

You can now toggle back to the held call (using **SHIFT + 4**) and retrieve it.

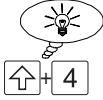

**Tip**

To toggle between the Call Status screens for each call, press **SHIFT** and **4**.

## Setting up CCBS (ETS) (VN) (TPH) (Completion of Calls to Busy Subscribers)

When you dial a busy number, CCBS instructs the network to activate a waiting state so that when the busy number becomes available the network calls you. You can then connect the call without having to make a new call.

Choose **SETUP** from the Main Menu to display the following screen.



Choose **ISDN** and use the **SCROLL** key to display the following screen.

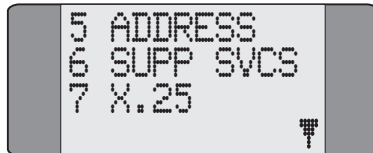

Choose **SUPP SVCS**.



Choose **CCBS** to display the following screen:



If you choose **ON**, **CCBS** requests are made if the destination is busy.

If you choose **OFF**, normal call clearing is used if the destination is busy.



#### Note

When you switch **AuroraPlus** off, **CCBS** is set to **OFF**.

## Making a Call with CCBS Enabled

Set up **CCBS** to **ON** (See *Setting up CCBS*).

From the Main Menu choose **CALLS** and select **DIAL**.

Enter the destination number and press **ENTER** (↵).

If the number is busy the following screen is displayed when the CCBS request has been sent.

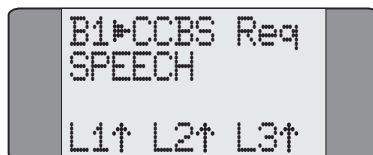

When the CCBS request has been accepted and the CCBS call is in the disconnect state, the following screen is displayed.



Press *ENTER* (↵) to clear the busy call.

When the busy call has been cleared, the CCBS request has been sent and the network has not yet called you back, the following Idle State screen is displayed.

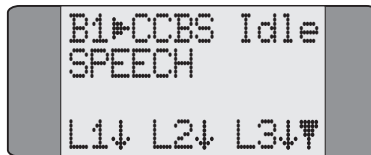

When the CCBS call is established, the progress of the call is displayed as follows:

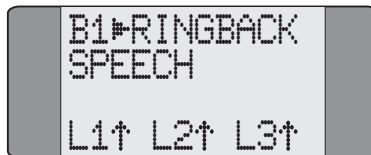

### **Deactivating the CCBS request**

You can only deactivate the CCBS request if:

- the busy call has been cleared
- the CCBS request has been sent
- the network is in the waiting state.

The following Idle State screen is displayed.

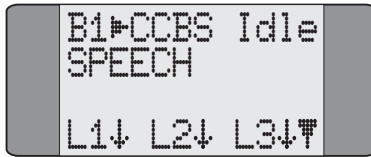

To deactivate the CCBS request, press *SCROLL* to display the following screen.

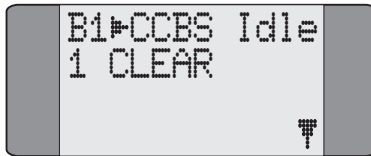

Choose *CLEAR* to stop the CCBS request.

The following screen is displayed briefly to indicate that deactivation has been sent.

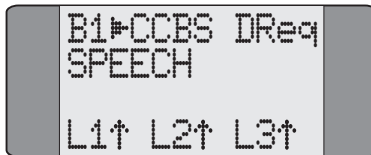

When the CCBS request has been deactivated successfully, the following screen is displayed.

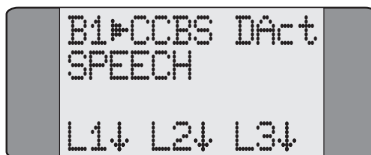

## CCBS Error Messages

If the CCBS request is not successful a screen similar to the following is displayed.

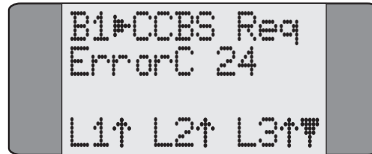

Press **SCROLL** to display the full error message. See the *CCBS Errors* table on the following page for more information.

CCBS Errors	
20	Invalid call linkage ID
21	Invalid call CCBS reference
22	Long term denial. For example, destination not subscribed to basic service or non-CCBS network.
23	Short term denial. For example, destination congestion or supplementary service interaction.
24	CCBS is already activated
25	Already accepted
26	Outgoing CCBS queue full
27	Call failure reason not busy
28	Not ready for call

## CCBS Options Not Supported by **AuroraPlus**.

- Interrogation of CCBS requests.
- Status request procedures.

## Suspending and Resuming a Call ETSI

When you have connected a call **AuroraPlus** enables you to disconnect from the network, reconnect to a different connection and resume the call.



### Suspending a call

From the Connect screen press *SCROLL* to display the **CONNECT** menu.



Choose **SUPP SVCS**.



To suspend the call, choose **SUSPEND**.

### Resuming a call

When you have reconnected **AuroraPlus**:

From the main menu choose **SUPP SVCS**.

The following screen is displayed:

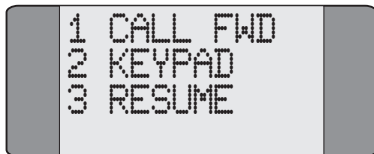

To resume the call, choose **RESUME**.

## User-to-User Signalling ETSI

User-to-user signalling enables you to send strings to another connection on the network. There are three types of user-to-user signalling:

- Service 1 - string sent during call setup and clearing phase
- Service 2 - string sent in the call alerting phase.
- Service 3 - during the active phase of the call

## Setting up User-to-user Signalling

You must set up user-to-user signalling before you connect the call:

Choose **SETUP** from the Main Menu to display the following screen.



Choose **ISDN** and use the *SCROLL* key to display the following screen.

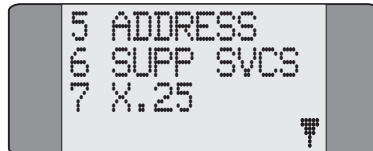

Choose **SUPP SVCS**.



Choose **UUS**, the following screen is displayed:



### Setting up Service 1 user-to-user Signalling

From the **UUS** menu choose **SERVICE**, the following screen is displayed.



From the **service** menu choose the **SERVICE 1**, the following screen is displayed.

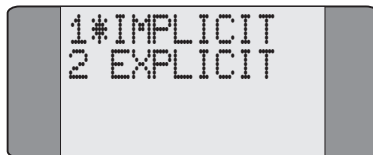

Choose whether you want to use **IMPLICIT** or **EXPLICIT** control of the user-to-user signalling.

If you choose **IMPLICIT** the UUI message is sent without requesting the service.

If you choose **EXPLICIT** a UUS service request is sent with the UUI.

To return to the UUS menu press *ENTER* twice.

To enter the message you want to send, choose **UUI**, the following screen is displayed.

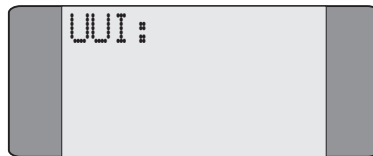

Enter the **UUI** you want to send.

To save the message and leave the screen, press *ENTER*.

When a call is being setup, the UUI message is sent in the SETUP message.

### **Setting up Service 2 user-to-user Signalling**

Service 2 UUI messages are sent in the alerting phase of the call. The INVOKE request is sent in the SETUP message for the call.

The process for setting up service 2 user-to-user signalling identical to that for service 1 user-to-user signalling except you do not choose between implicit and explicit signalling.

### Sending a Service 2 User-to-user message

While a call is ringing:

Press the *SCROLL* button, the following screen is displayed:



Choose **UUS SRV 2**, the following screen is displayed:

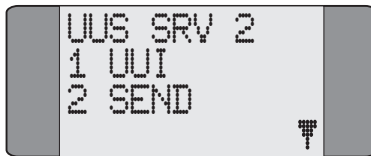

To enter the UUI message choose **UUI** and enter the message.

To send the message, choose **SEND**.

To send another message, repeat the steps above.

### Setting up Service 3 user-to-user Signalling

Service 3 UUI messages are sent when a call is connected.

The INVOKE request can be sent either in the SETUP message for the call or manually during the call.

To set up service 3 UUI messages, with the INVOKE request sent in the SETUP message:

From the UUS menu choose **SERVICE**.



From the service menu choose the **SERVICE 3**.

If you want to enter the message you want to send, choose **UUI**, the following screen is displayed.

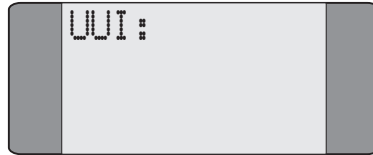

Enter the **UUI** you want to send. You can enter up to 32 characters.

You can also enter the message just before you send it.

To save the message and leave the screen, press **ENTER**.

## Sending an INVOKE Request

If **AuroraPlus** has not sent an INVOKE request in the SETUP message you must do so manually before you can send the UUI message. If the INVOKE request has already been sent you do not need to perform these steps.

When the call is connected:

From the connected screen press the **SCROLL** button, the following screen is displayed:

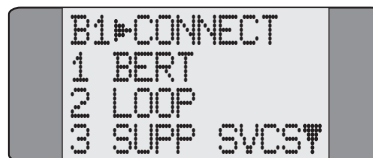

Choose **SUPP SVCS**.

From the supplementary services menu, choose **UUS SRV 3**.  
The following screen is displayed:

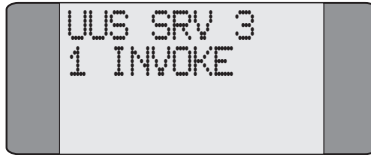

To send an INVOKE request, choose **INVOKE**.

To return to the connected menu, press **CLEAR** twice.

### **Sending a service 3 UUI message**

When you have connected the call:

From the connected screen press the **SCROLL** button.

Choose **SUPP SVCS**.

To enter a new UUI message, choose **UUI**. The following screen is displayed:

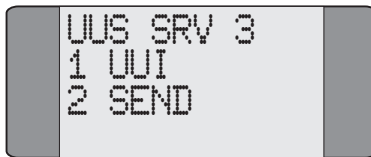

Choose **UUI**.

Enter the message you want to send, then press **ENTER**.

To send the UUI message choose **SEND**.

When the UUI message has been sent successfully the following screen is displayed.



## Choosing how **AuroraPlus** Responds to UUS INVOKE Requests

You can choose how **AuroraPlus** responds to UUS INVOKE requests that are received from the network:

From the Main Menu choose **SETUP**.

The **SETUP** menu is displayed

Choose **ISDN**.

The **ISDN** menu is displayed.

Choose **SUPP SVCS**.

From the **SUPP SVCS** menu choose **UUS**.

The **UUS** menu is displayed.

Choose **SRV 3 MODE**.

The following menu is displayed:



If you choose **ACCEPT**, **AuroraPlus** accepts any UUS INVOKE requests it receives.

If you choose **REJECT**, **AuroraPlus** rejects any UUS INVOKE requests it receives.



This section discusses the various functions and tests provided by **AuroraPlus** that allow you to quickly check the line under test. These tests give you information about the line such as the protocols, the bus configuration and the teleservices that can be used. The BER Test, Tracer and Self Test functions are also discussed.

## Autotest

### Setting up the Autotest

From the main menu choose **SETUP**.

Choose **AUTOTEST**, following menu is displayed:

```
AUTOTEST
1 SELECT
2 SRV:T-ISDN
3 BERT
```

To select the tests included in the autotest, choose **SELECT**.

```
AUTOTEST
1\CALLS
2\SERVICE
3\BERT
```

To choose an item, press the key for the item, to deselect the item press the key again.

To choose the bearer service you want to use for the call, choose **SRV**, and choose the service you want to use.

To set up the duration of the BERT, choose BERT.  
For detailed information on choosing a custom duration see  
Setting the BER Test Length in Chapter 3.

Press *ENTER* to return to the setup menu.

## Running the Autotest

From the main menu choose **AUTOTEST**. A dial screen is  
displayed:



Enter the number you want to connect to, then press  
*ENTER*.

For the autotest to work this must be a self-call.

The tests you have selected are run. As the tests proceed the  
results are displayed. When the tests have finished:

a tick (✓) indicates that the test was completed successfully,  
not that the test was passed

a cross (X) indicates that the test was failed

a dash (-) indicates that the test was not chosen.

To display the test results press *ENTER*. The following menu  
is displayed:



To display the BERT results, choose **BERT**.

To display the service test results, choose **SERVICE**.

## Checking the Line Configuration



The Configuration Check determines:

- the protocol that can be used on the line
- the layer 2 configuration in use (i.e. Point-to-Point or Point-to-Multipoint)

When the test ends, **AuroraPlus** displays the protocol and layer 2 configuration found on the line and gives you the option to automatically re-configure **AuroraPlus** for this line.



### Notes

- Although the Configuration Check can distinguish between the ETSI and 1TR6 protocols, it cannot distinguish between ETSI, TPH and VN.
- Some ETSI networks show both Point-to-Point and Point-to-Multipoint configurations for Basic Rate interface: either can be used.
- A U interface may take several minutes to activate, when you check the line configuration this may lead to false readings.

From the Main Menu choose **TESTS**.



Choose **CONFIG**.

**AuroraPlus** checks the line and displays a results screen similar to the following:



1	1TR6	FP	X
2	1TR6	PMP	X
3	ETSI	FP	X
4*	ETSI	PMP	✓

A tick (✓) is displayed against valid configurations for the line. A cross (X) is displayed against invalid configurations.

If any protocol tested passes the configuration test with a Point-to-Point line type, the Point-to-Multipoint test is not performed and ? is displayed on the screen.

## Automatically configuring the line under test

To automatically configure **AuroraPlus**, key in the number associated with a valid configuration. Using the example above, you could input **4** to automatically configure **AuroraPlus** for ETSI Point-to-Multipoint.

## Service Check: Determining Available Services



The Service Check determines the ISDN services subscribed to on the line under test, and tells you which ones are available.

You can perform a Local or a Remote Service Check:

### Local Service Check

This tests the acceptance of calls at the device **AuroraPlus** is connected to - for example, your local exchange.

**RemoteServiceCheck** This tests service availability for a remote designated terminal across the entire ISDN.

To access the Service Check, choose **TESTS** from the Main Menu.

Choose **SERVICE**. An asterisk (\*) is displayed against the current selection.



### Note

The results of the Service Check are held in the **AuroraPlus**'s RAM. When you switch off **AuroraPlus** the results are lost.

## Performing a Local Service Check

If you choose to perform a **LOCAL** test the results cannot be guaranteed, due to different network setups.

Choose **LOCAL** to perform a Local Service Check.



Press **ENTER** to start the test. **AuroraPlus** checks each service in turn. Refer to *Understanding Service Check Results* for information on what is displayed.

## Performing a Remote Service Check

Choose **REMOTE** to perform a Remote Service Check.



Press *ENTER* to start the test. A Dial Screen is displayed.



Enter the number you wish to dial (or use Speed Dialling) and then press *ENTER* (↵) to dial the number.

## Understanding Service Check Results

**AuroraPlus** checks each ISDN service and displays the result of each test. A tick (✓) is displayed against available services; a cross (✗) is displayed against those that are unavailable. Any service not tested is indicated by a hyphen (-). When the test is complete the service test results screen is displayed.

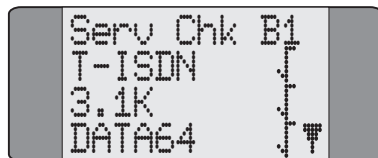

To redisplay the results of the test; access the **RESULTS** menu option.



### Note

To abort the Service Check at any time, press *ENTER*.

## The X.25 Test



The X.25 Test uses SAPI 16 to check the TEIs which are available for X.25 packet data transfer on the line under test.

Choose **TESTS** from the Main Menu.

Choose **X.25** to begin the test:

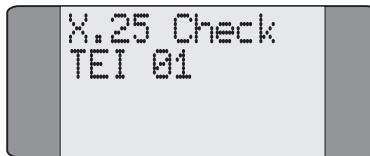

TEIs 1 to 63 are checked, sequentially. This may take up to four minutes to complete. Once all the TEIs have been checked, the first ten available TEIs are displayed.

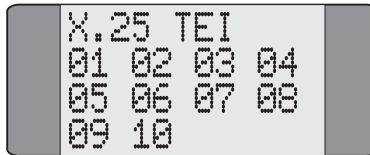

If no TEIs are available **No X.25 TEI Available** is displayed.



To abort the test at any time, press **ENTER**.

## Testing Fixed Links

Fixed Links are simple Point-to-Point lines where no protocol is used - in other words there is no D Channel signalling. **AuroraPlus** can be used to test fixed links in one of two ways:

- by sending a BER Test pattern, which can be looped back by the remote end. The received pattern is then compared with what was sent.
- **AuroraPlus** may be set up to loop back a test pattern to another tester using the second B Channel.

Choose **TESTS** from the Main Menu to display the **FXD BERT** and **FXD LOOP** options.

Choose **FXD LOOP** to set **AuroraPlus** to loop back a test pattern to another tester. The display shows **Fixed Loop**.

Choose **FXD BERT** to send and loop back a BER Test pattern. **AuroraPlus** displays the BER Test Screen - please refer to *Performing a BER Test* in this chapter for further information.

## Performing a BER Test

The BER (Bit Error Rate) Test is used to check the integrity of the ISDN line. It does this by generating a test pattern which it then receives back. The received pattern is compared with the transmitted pattern and an error count is given.

**AuroraPlus** can store up to 10 BER test results.



### Note

The stored BER test results are kept:

- if you have a line-powered **AuroraPlus** while power is being supplied by the line
- if you have a battery-powered **AuroraPlus** only while the battery is charged.





### Note

If you restore the factory defaults, the BER test results are deleted.

To perform a BER Test you first need to establish a call. This call may be to either the other B Channel on **AuroraPlus** (i.e. a 'Self Call') or to another remote tester or loopbox. If the other B Channel is called and **AuroraPlus** is set to loop automatically, it answers the incoming call on the other channel and provides a loop, for information on how to set up a loop see *Changing the Loop Options* in Chapter 3.

## Downloading BERT Results to a PC

You can automatically download results from a BER Test to a PC or printer.

First connect **AuroraPlus** to the PC (or printer) using the serial connector supplied.

Select **TRACER** from the **Setup** Menu.



Choose **BERT** to enable the automatic download of BER Test results. Press **ENTER** to save your selection.

Now perform a BER Test, as described in the next section. As soon as **AuroraPlus** completes the BER Test, the results are transmitted down the serial port to the connected device.

If you have already performed a BER test and the results are in the **AuroraPlus** memory:

Connect **AuroraPlus** to the PC and switch on the tracer as described above.

Select **RESULTS** from the **Setup** Menu.



Choose **BERT** then use the **SCROLL** key to step through the results. As you step through the results they are displayed on the PC.

## Starting a BER test

You can specify that you want to make a BER test in two ways, when you have connected a call, or before you connect a call.

When you are performing a BER test you can make a self-call, **AuroraPlus** then automatically loops the call back on the other B-Channel.

### Specifying the BER test when a call has been connected

From the Main Menu choose **CALLS**. The following screen is displayed:



Choose **DIAL** and enter the Called Party Number - please refer to *Dialling* in Chapter 4 for further details.

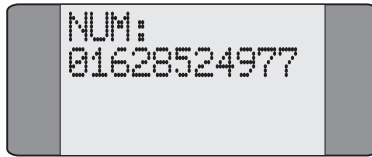

When the call is established a screen similar to the following is displayed:



Press *SCROLL* to display the Call Control options:

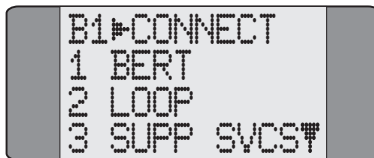

Choose **BERT** to begin the BER Test. A screen similar to the following is displayed:

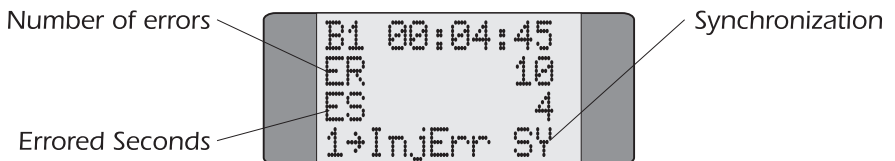

The test runs for the duration set in the Bert Setup Screen (please refer to *Setting the BER Test Length* in Chapter 3 for further information) and the call is then cleared.

To inject errors into the BER pattern, press **1**.



Press **ENTER** at any time, to stop the test.



**Note**

**SY** is displayed when the BERT pattern is synchronized. **Sync Lost** is displayed otherwise.

**Specifying the BER test before the call has been connected**

From the main menu press + **5**, the following is displayed:

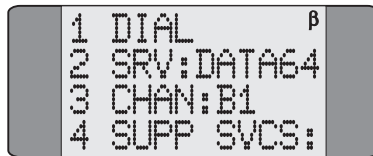

Choose **DIAL** and enter the Called Party Number - please refer to *Dialling* in Chapter 4 for further details.

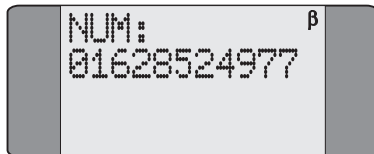

When the call is established a screen similar to the following is displayed:



When the call is connected a screen similar to the following is displayed:

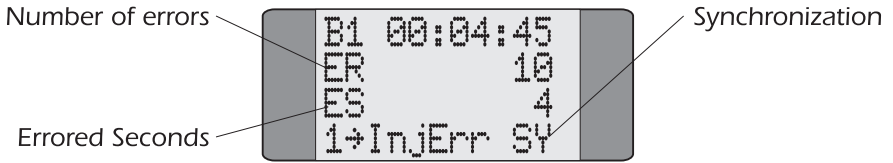

The test runs for the duration set in the Bert Setup Screen (please refer to *Setting the BER Test Length* in Chapter 3 for further information) and the call is then cleared.

To inject errors into the BER pattern, press **1**.



Press **ENTER** at any time, to stop the test.



### Note

**SY** is displayed when the BERT pattern is synchronized. **Sync Lost** is displayed otherwise.

## Understanding the BER Test Results

You can store up to 10 sets of results in **AuroraPlus**'s memory and these are numbered from 0 to 9. Each BERT result consists of two screens showing the parameters specified in G.821. These parameters are explained below:

- Total Kilobytes (KB), received after synchronisation
- Error Count (ER), the number of errors received
- Errored Seconds (ES), the number of seconds in available time containing any errors
- Error Rate (RT), the number of errors detected divided by the number of bits received

- Severely Errored Seconds (SES), the number of seconds of available time containing more than 64 errors.  
Available time is the total length of the test minus unavailable time.  
Unavailable time is any period of 10 or more consecutive seconds, when every second contained more than 64 errors.
- Degraded Minutes (DM), the available time in seconds minus the Severely Errored Seconds are bundled together as groups of 60 seconds. The groups of 60 seconds are then counted. The number of Degraded Minutes is the total number of groups that contained more than 4 errors

Choose **RESULTS** from the Main Menu. If no results are stored, **Buffer Empty** is displayed.



```
BERT STORE 0
KB      19651
ER      5.08E-7
ES      107
```



```
BERT STORE 0
SES      1
DM      1
RT      47
```



```
BERT STORE 0
CPN: 1234
      7
```



Use the **SCROLL** key to step through the BERT results.



### Notes

- Up to 10 BERT results may be stored, providing power is not removed from the unit.
- If subsequent BER Tests are run **AuroraPlus** begins overwriting the oldest data first.

## Displaying Test Results

You can display the last test results which are held in the unit's memory for as long as the power is switched on. These include:

- BER Test results
- the last Service Check
- Tracer results
- Autotest results

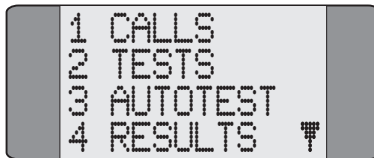

Choose **RESULTS** from the Main Menu.



- Choose **BERT** to display the BERT Results Screen. Refer to *Understanding the BER Test Results* in this chapter for further details.
- Choose **SERVICE** to display Service Check results. Refer to *Understanding Service Check Results* in this chapter for further information.

- Choose **TRACER** to display any stored ISDN signalling information - please refer to *Displaying Tracer Output* below.

## Displaying Tracer Output

The Tracer is the name given to the **AuroraPlus** function which lets you capture detailed ISDN signalling information from the D (Demand) Channel to **AuroraPlus**'s memory. This information is sometimes called 'Decode'.



### Note

Tracer Results are held in the **AuroraPlus**'s RAM. When you switch off **AuroraPlus** the results are lost.

For details on how to capture Decode, please refer to *Tracer Setup* in Chapter 3. The following section describes how to display the Decode, download it to a PC using the serial port and how to erase it from **AuroraPlus**'s memory.

Choose **RESULTS** from the Main Menu.

Choose the **TRACER** option.

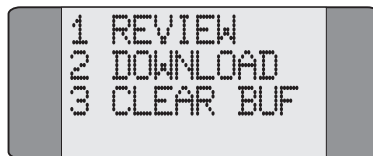

Choose **REVIEW** to display the stored Decode information. If no data is stored **Tracer Buffer Empty** is displayed:

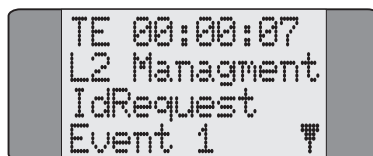



### Navigating through the Decode

Up to 99 lines of decode may be stored in **AuroraPlus**'s memory and this is likely to span several pages. Use the following keys to cycle through the decode:

 To page down, use the *SCROLL* key.

 To page up, use the *CLEAR* key.

 To go to the first page, press *0*.



#### Tip

To go directly to a line of decode, press the first digit of the line number. For example, to go to line 20, press **2**.

## Downloading Tracer Results to a PC

First connect **AuroraPlus** to the PC using the serial connector supplied.

Set the PC to the following:

Baud Rate	9600
Data Bits	8 bits
Parity	None
Stop Bits	1
Protocol	ETSI (Basic rate)
Layer 1	On
Layer 2	Full
Layer 3	Full
filters	no filters selected
capture	download, with display, with statistics
Preferences	Embedded Hex

Choose **DOWNLOAD** to begin downloading the stored decode through **AuroraPlus**'s serial port to the PC.



When **AuroraPlus** begins downloading to the PC the following screen is displayed:

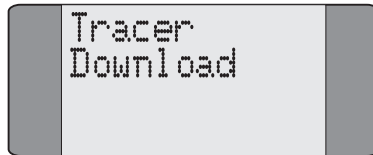

Check the PC screen to determine when downloading is complete.



Press **CLEAR** to exit the Download Screen.

## Clearing Tracer from Memory

Choose **CLEAR BUF** to erase the stored Decode from **AuroraPlus**'s memory.

The following screen is displayed, asking you to confirm whether you want to clear the buffer or not :

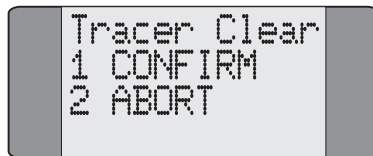

Choose **CONFIRM** to erase the Tracer Decode or **ABORT** to retain it.



### Note

When you erase the Tracer Decode the Tracer is switched off. If you want to use the Tracer again you must switch it on.

## Saving Results

As well as saving results in a buffer that is cleared when AuroraPlus is switched off you can save one set of results in memory. These results are retained when you switch off AuroraPlus.

### Saving a Set of Results

From the results menu press **SCROLL** to display further options:

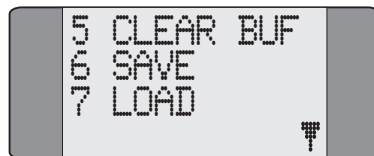

Choose **SAVE**.

The following screen is displayed.

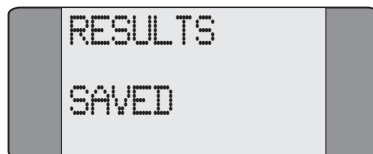

Press **ENTER** to return to the results menu.

## Displaying Results You Have Saved

Before you can display the set of results you have saved you must load them into **AuroraPlus**'s memory. To do this:

From the results menu press *SCROLL* to display further options.

Choose **LOAD**.

The results are copied into RAM. Any results in memory are overwritten and the following screen is displayed.

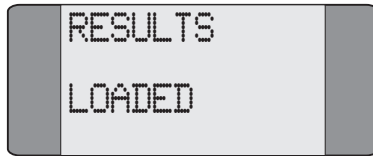

Press *ENTER* to return to the results menu.

## Sending Results to a PC

AuroraPlus enables you to send a test report in text or CSV (Comma Separated Variables). The test report can be customised to include a customer and operator name. The date and time of when you printed the report is also added to the report.

## Entering the Customer and Operator Names

From the main menu choose **SETUP**.

From the setup menu choose **TESTREPORT**. The following screen is displayed:

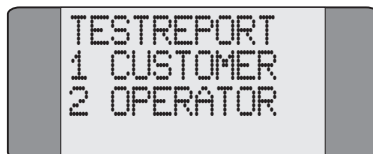

Choose **CUSTOMER** or **OPERATOR**. A screen similar to the following is displayed:



Enter the customer or operator name you want to add.

Press *ENTER* to save the name and leave the screen.

## Sending the Report

Connect **AuroraPlus** to the PC you want to send the results to using the serial cable supplied with **AuroraPlus**.

Set up your PC so that the serial port connected to **AuroraPlus** is set to the following:

bits per second	9600 bps
data bits	8
parity	no parity
stop bits	1
flow control	off

Open the terminal emulation programmed you are going to use.

From the results menu choose **TESTREPOR**. The following screen is displayed:



Choose **TEXT** or **CSV**.

The report is sent to the PC.

CSV format is often used when you want to import the report into a spreadsheet.

## Self Test Functions

The Self Test function gives you access to additional features which are not used regularly or do not appear on the menu.

The Self Test feature lets you set configuration parameters such as Pulse Width settings or Flash Timing for analogue lines. It also lets you check flash memory and install new software on **AuroraPlus**.



### Note

Calls are not indicated during a Self Test.

Choose **SETUP** from the Main Menu.

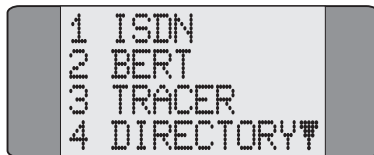

Press the *SCROLL* key to display the second page of Setup options:

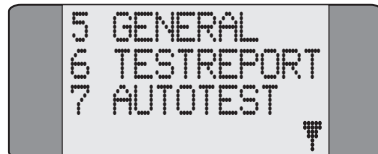

Choose **GENERAL**.

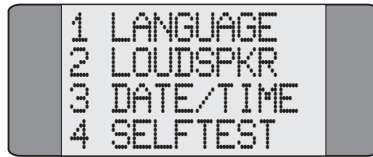

Choose **SELFTEST**.

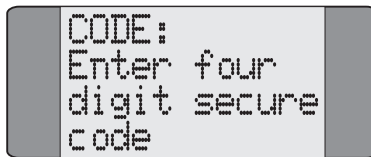

Enter a Facility Access Code (FAC). The FAC tells **AuroraPlus** which Self Test facility you wish to perform. The codes are as follows:

- 3570** - use this code to access **AuroraPlus**'s Self Test facilities
- 1590** - use this code to check and download to **AuroraPlus**'s Flash Memory.





Enter the appropriate four digit FAC and press **ENTER**.

## Performing a Self Test Function

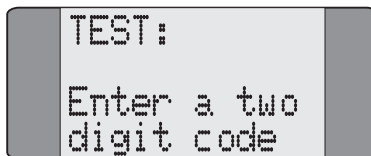
When you enter a FAC code of **3570** (the code for accessing the Self Test facilities) the following screen is displayed:



Enter the appropriate two digit code which corresponds to the facility you wish to perform. The table overleaf lists all the available tests and their corresponding codes:

<b>AuroraPlus Self Test Facilities</b>		
<b>Test Code</b>	<b>Function</b>	<b>Description</b>
01	Display Test	Lets you scroll through a list of characters to test all elements of the display. Use the <b>SCROLL</b> button  to step through the display. Press <b>ENTER</b> to end this test.
02	FLASH Checksum	Displays FLASH checksum. Use this to check that the software has no errors.
03	Keypad Test	Use this to check the keypad. For each button press a corresponding description is displayed on-screen. For example, press <b>7</b> and <b>7</b> is displayed; press  and <b>CLEAR</b> is displayed. Stop the test by pressing the <b>ENTER</b> button  .
04	Internal Hardware Check	Performs automatic test of internal hardware and reports a result e.g. <b>TEST OK</b> or <b>ERROR</b> .
05	Software Release	Displays the current release of software e.g. <b>REVP:V1.02:G</b> .
06	Ringer Check	Continuously sounds the ringer to verify it's operation. Displays <b>CONTRING</b> .
09	96 kHz at S Interface	Transmits a 96kHz signal at the S Interface for wiring/connectivity check. Displays <b>S96KHZ</b> .
12	Polarity Check	Checks a signal input polarity against an internal reference. Displays <b>SPOLARITY OK/NOT OK</b> .
13	Resets EEPROM	Restores <b>AuroraPlus</b> to original factory settings. This is useful if the unit's state is unknown. Displays <b>SET DEFAULT OK/ERROR</b> .
20	Set Serial Number	Enables you to enter a Serial Number. Note: to enter '/' press SHIFT+*
40	A-Law Encoding	Sets encoding type to A-law for use in Europe. Displays <b>SET A-LAW</b> .
41	μ-Law Encoding	Sets encoding type to μ-Law for use in the US, Japan and Asia. Displays <b>SET μ-LAW</b> .
45	40KHz Tone On	-12dBm tone generation for testing the attenuation of lines. Press <b>2</b> then <b>ENTER</b> to end this tone generation. Displays <b>40KHz</b> .
50	Insert 0 or 00	Automatically adds 0 or 00 to the display of incoming national or international calls. Displays <b>NUM PLAN ON</b> .
51	Remove 0 or 00	Removes 0 or 00 for incoming national and international calls. Displays <b>NUM PLAN OFF</b> .
59	Flash Time 100ms	Defines the Timed Break used by modern analogue exchanges to access additional services. Region specific. Displays <b>FLASHTIME 100MS</b> .
60	Flash Time 300ms	Defines the Timed Break used by modern analogue exchanges to access additional services. Region specific. Displays <b>FLASHTIME 300MS</b> .
61	Flash Time 600ms	Defines the Timed Break used by modern analogue exchanges to access additional services. Region specific. Displays <b>FLASHTIME 600MS</b> .
continued on next page...		



AuroraPlus Self Test Facilities continued		
Test Code	Function	Description
62	DTMF Level -6/-8dBm	Sets the DTMF signal strength. Region specific. Displays <b>DTMF LEVEL -6/-8dBm</b> .
63	DTMF Level -9/-11dBm	Sets the DTMF signal strength. Region specific. Displays <b>DTMF LEVEL -9/-11dBm</b> .
64	Charging Frequency 16kHz	Defines the frequency measured to detect analogue charging meter pulses. Displays <b>Meter Pulses 16KHz</b> .
65	Charging Frequency 12kHz	Defines the frequency measured to detect analogue charging meter pulses. Displays <b>Meter Pulses 12KHz</b> .
66	Disable Call Charge Display	Disables display of call charge based on analog charging pulse. Displays <b>Analog OFF</b> .
67	Enable Call Charge Display	Enables display of call charge based on analog charging pulse. Displays <b>Analog ON</b> .
68	Analog Dial Pulse 40/60	For pulse dialling; sets the on/off ratio of each number's dialling pulse. Region specific. Displays <b>A Dial Mode Pulse 40/60</b> .
69	Analog Dial Pulse 33/66	For pulse dialling; sets the on/off ratio of each number's dialling pulse. Region specific. Displays <b>A Dial Mode Pulse 33/66</b> .

**AuroraPlus** responds to the Self Test code and displays the results. In the following example, software release information has been requested:

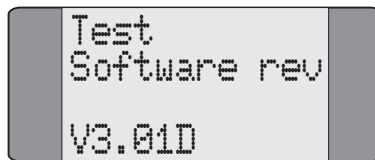

Press **ENTER** - **AuroraPlus** prompts you for the next test code.



### Note

If you have downloaded new software to you **AuroraPlus**, when you use Test Code 04 the error 10 may be displayed, this is because the checksum of the new software is different to the checksum of the old software . To correct this choose Test Code 13.

To exit from this screen, enter a code of **99**.

## Upgrading AuroraPlus Software

This Self Test facility enables the software in Flash Memory to be checked and downloaded from an external source, such as a PC. To perform these operations, you need to install the TrendSend file transfer application on the PC. This Windows application is available from [www.trendcomms.com](http://www.trendcomms.com).

### Connecting AuroraPlus to the PC

Connect **AuroraPlus** to the PC using the supplied serial cable.

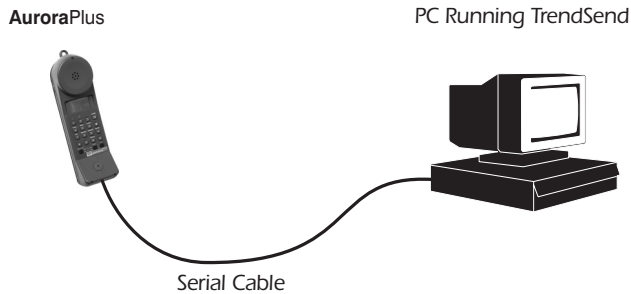

Ensure **AuroraPlus** has an adequate power supply and then switch it off.

Start the TrendSend application on the PC.

Display the **Configuration** menu and choose **Unit**.

Choose **AuroraPlus** and if the download type list box is displayed choose **binary**, then choose **OK**.

To set a different serial port on the PC, display the **Configuration** menu and choose **Comm**, choose the com port you want to use, then choose **OK**.

Now switch **AuroraPlus** on. **AuroraPlus** sends information to the PC and a screen similar to the following is displayed:

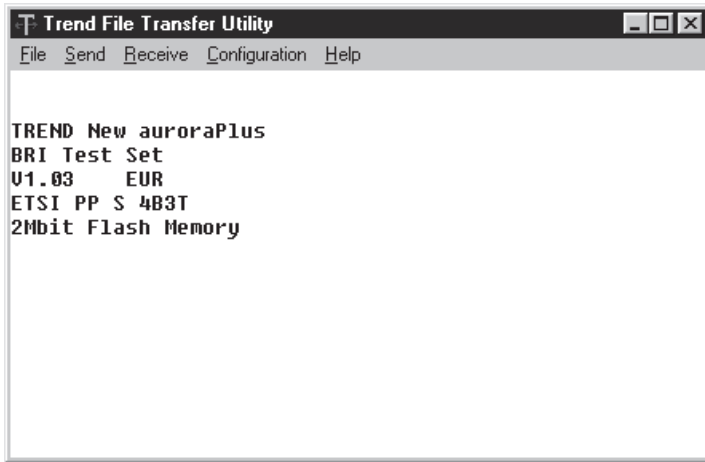

### Installing New Software

Trend Communications Ltd. provides new software via the Internet ([www.trendcomms.com](http://www.trendcomms.com)). To download new software you need to copy the appropriate file to the PC running the TrendSend application:

Copy the file containing the new software into the **TrendSend\transfer** directory on the PC - the file must be called **Pluscode.hex** so rename it if necessary.

Connect **AuroraPlus** to the PC, as described in the previous section.

To start downloading the software, display the **Send** menu application and choose **Plus**.

When you are prompted to start downloading by TrendSend, on **AuroraPlus**, choose **SETUP** on the main menu; then the **Selftest** option and enter a FAC code of **1590** (the code for checking and downloading to flash memory). The following screen is displayed:



Press **1** to update the software.

The software download begins and the PC displays a progress bar:



If you are using Windows 95 the download procedure takes about 15 to 20 minutes to complete, if you are using Windows 3.1 the procedure may take longer. It is important to ensure that the power supply and serial cable remain connected during this operation.

When downloading is complete the PC displays **Sent transfer\pluscode.hex**, followed by the number of bytes transmitted. **AuroraPlus** displays **DL END** and then resets itself.



### **Note**

If you encounter problems during the download procedure, choose **File/Abort** from the TrendSend application. Switch **AuroraPlus** off and then choose **Send/Plus** and switch **AuroraPlus** on. The download procedure restarts.

If you have problems with downloading the software the message Hardware not compatible is displayed, it may be because:

The memory in **AuroraPlus** is not compatible with the software you have downloaded.

**AuroraPlus** is loaded with 2B1Q software and you have tried to download 4B3T software to it or vice versa.

The CPU clock frequency is not correct for the software you have tried to download.

## Performing a Status Check

This feature is protocol specific.

- ETSI
VN
  - In the ETSI and VN protocols, the Status Check option lets you interrogate the network for information about any Call Forwarding settings which may be present.
- 1TR6
  - In the 1TR6 protocol, performing a Status Check displays the active facilities on the line such as Call Forwarding settings, Call Charging and Closed User Groups (CUGs).
- ~~TPH~~
  - ~~TPH~~ does not support Call Forwarding or other supplementary services.

## Checking Call Forwarding Status ETSI

The **STATUS** option provides information about Call Forwarding settings. **AuroraPlus** displays the following information:

- the CLI for which Call Forwarding is programmed
- the type of Call Forwarding
- the service type
- the address to which Call Forwarding is directed.

Choose **CALLS/SUPP SVCS/CALL FWD** from the Main Menu.

Choose **STATUS** to display a screen showing details of any Call Forwarding settings:

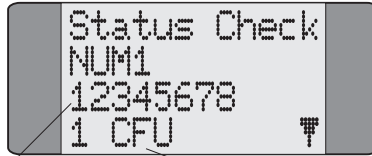

MSN

Call Forwarding type



Press **SCROLL** repeatedly to move through the information one line at a time.

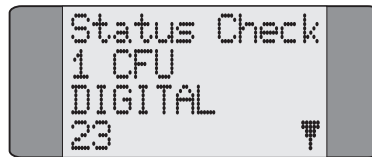

If more than one Call Forwarding setting is programmed, information is displayed in the following sequence:

NUM 1

CLI

CF-Type

Basic Service

Forwarded-To-Address

Basic Service

Forwarded-To-Address

CF-Type

Basic Service

Forwarded-To-Address

NUM 2  
 CLI  
 ..... and so on.



### Notes

- If no Call Forwarding settings are present **Nofac** is displayed.
- **Timeout** is displayed if there is no response from the network.

## Checking Call Forwarding Status <sup>VN</sup>

The **STATUS** option provides information about Call Forwarding settings. **AuroraPlus** displays the number to which calls are being redirected.

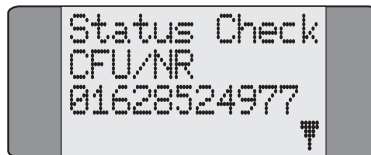

Press **SCROLL** to display any further redirection information returned by the network.



### Notes

- If no Call Forwarding settings are present **Nofac** is displayed.
- **Timeout** is displayed if there is no response from the network.

## Checking Active Facilities <sup>1TR6</sup>

In the 1TR6 protocol, the **STATUS** option displays the active facilities on the line. **AuroraPlus** displays the following information:

- **LINE DIVERT** is shown, together with the call forwarding number, if AWS1 is activated.

- **CALL REDIR** is displayed, together with the call forwarding number, if **AWS2** is active.
- **MCI** is shown if Malicious Call Identification is currently activated.
- **CUG** is displayed if a Closed User Group is activated.
- **CHARGING** is shown if Call Charging is active.
- **BLOCK** is displayed if any call barring settings are active on the line. The following table explains the call barring codes which may be displayed.

Call Barring Status Codes	
Code	Explanation
2	All outgoing calls are barred
3	Long Distance outgoing calls are barred
4	International outgoing calls are barred
5	Intercontinental outgoing calls are barred

Choose **CALLS/SUPP SVCS/CALL FWD** from the Main Menu.

Choose **STATUS**. After a short delay, while **AuroraPlus** checks the network, a screen similar to the following is displayed:

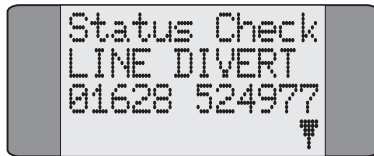

Press **SCROLL** repeatedly to display all the active facilities on the line.

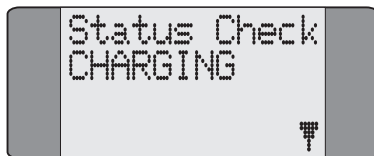





Press *ENTER* to exit the Status Request screens.



### Notes

- If no facilities are set **Nofac** is displayed.
- **Rejected** is displayed if the network does not respond.



### Tip

You can also access the Status Request option by selecting **STATUS/STATUSENQ** from the Main Menu.

## Displaying Far End Block Errors/Near End Block Errors (FEBE/NEBE)

When using the 2B1Q-interface, the internal error counters of the U Interface circuit can be displayed.

Far End Block Errors (FEBE) indicate errors in the *Transmit* direction. Near End Block Errors (NEBE) indicate errors in the *Receive* direction.

Press *SHIFT+0*.

If no call has been connected since you switched on **AuroraPlus**, counts for NEBE and FEBE are displayed.

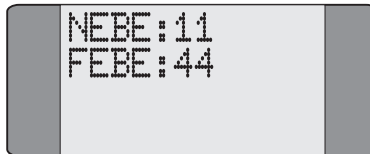

If a call is connected, or has been connected since you switched on **AuroraPlus** the following screen is displayed:

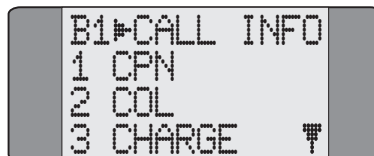



Press *SCROLL* to display further options, then choose **NEBE-FEBE**.

Counts for NEBE and FEBE are displayed.



**Note**

The maximum FEBE/NEBE count is 256; once this number is reached no further errors are shown. Both counters are reset after being read.

## Checking **AuroraPlus's** Status and the Line Voltage



The **AuroraPlus** Status Check displays the unit's current settings. It shows the protocol, the line connection type on layer 2 (i.e. Point-to-Point or Point-to- Multipoint), the interface, the line supply voltage and the Loop option selected. You can run this check from *any* screen.



Press *SHIFT* and *HASH* (#) to trigger the Status Check. A screen similar to the following is displayed:

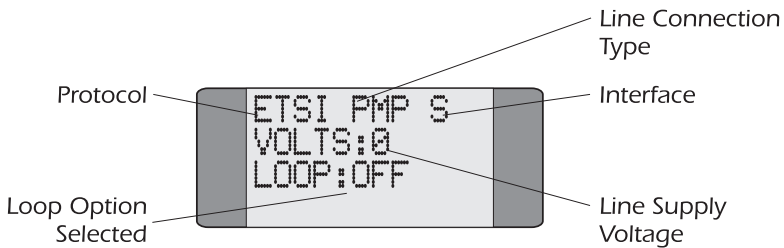

## X.25 Calls

This chapter provides operating instructions for X.25 Generic Packet Mode Support provided by the **AuroraPlus**.

The **AuroraPlus** supports incoming and outgoing X.25 packet switched calls, for test purposes, over the D channels of the ETSI ISDN Basic Rate interfaces. When you use **AuroraPlus** to make a X.25 call it acts as the DTE (Data Terminal Equipment).

### What is D-channel X.25 ?

This is an X.25 protocol with access to ISDN virtual circuit services on the D-channel. A call is made to the remote equipment using the D-channel. Because the amount of ISDN signalling data is very low, both the ISDN signalling data and the X.25 packet data can be multiplexed on the same D-channel.

### Setting up an X.25 call

From the Main Menu, choose **SETUP**:

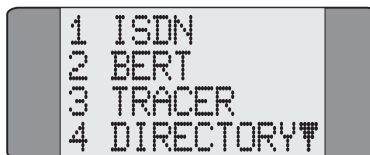

Choose **ISDN** from the **Setup** Menu to display the following screen:

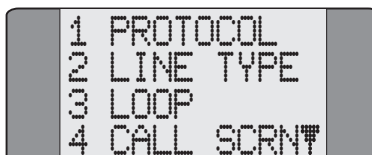



Use the **SCROLL** key to display the second page of ISDN options.



Choose the **X.25** option.



### Entering the X.25 address (LCGN & LCN)

X.25 uses a 12 bit address, which is made up of:

- an 8 bit Logical Channel Number (LCN) between 0 and 255
- a 4 bit Logical Channel Group Number (LCGN) between 0 and 15.

The LCGN and LCN are set up using different menu items.

To set the LCGN:

Choose **LCGN** from the **X.25** menu to change the Logical Channel Group Number. The following screen is displayed:

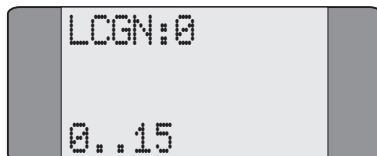

Enter the LCGN number you want to use.



Press the *ENTER* key to confirm your choice.

To set the LCN:

Choose **LCN** from the **X.25** menu to change the Logical Channel Number. The following screen is displayed:

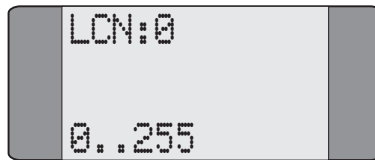

Enter the LCN number you want to use.



Press the *ENTER* key to confirm your choice.

### Changing the Closed User Group

A closed User Group is a group of subscribers on a network that are configured so that calls to and from the group can be restricted. You can set up **AuroraPlus** so that you can call into a CUG.

To change the CUG, choose **CUG** from the **X.25** menu. The following screen is displayed:

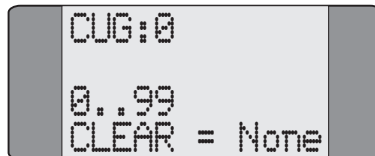

Enter the CUG you want to use.



Press the *ENTER* key to confirm your choice.

### Changing the Recognised Packet Operating Agency

RPOA is a facility to provide information on routing of X.25 calls. It is only used on networks in the USA. In the rest of the world we recommend that you set the RPOA to **None**.

### Switching Reverse Charging on and off

To change how **AuroraPlus** handles reverse charging:

**ON** allows **AuroraPlus** to accept an incoming reverse charge call. This includes a request for reverse charging, and also requests reverse charging on an outgoing call. **OFF** causes **AuroraPlus** to reject an incoming reverse charge call. This includes a request for reverse charging, and a request not to reverse the charging on an outgoing call.



In the **X.25** menu use the *SCROLL* key to display the second page of X.25 options:

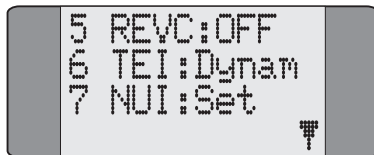

Choose **REVC** from the **X.25** menu to switch Reverse Charging on or off. The following screen is displayed:



Choose the setting you want.



Press the *ENTER* key to confirm your choice.

### Changing the Terminal Endpoint Identifier

On a Point-to-Multipoint line TEIs may be allocated by the PABX in the range 64 to 126 when the terminal is first plugged in. Alternatively the terminal has a fixed TEI in the range 1 to 63.

**AuroraPlus** allows you to fix the TEI you are going to connect to or to have a dynamic TEI.

Most packet handlers can provide connection for only certain TEIs **AuroraPlus** allows you to check which TEIs are available. For more information see *The X.25 Test* in *Chapter 5*.



In the **X.25** menu use the *SCROLL* key to display the second page of X.25 options:

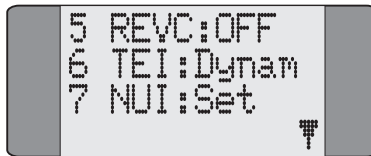

Choose **TEI** from the **X.25** menu to change the type of TEI. The following screen is displayed:



To choose a dynamic TEI:

Choose DYNAMIC then press the *ENTER* key to confirm your choice.

To choose a fixed TEI:

Choose FIXED, the following screen is displayed:

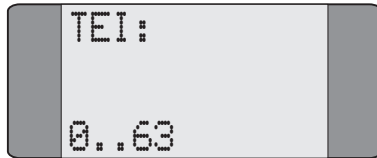

Enter the TEI you want to use.



Press the *ENTER* key to confirm your choice.

### Setting a Network User Identifier

You can send an NUI to the network along with the request for an outgoing call. An NUI is an alphanumeric string of up to 12 characters which identifies the user to the network.

The NUIs for a particular network are defined by its users. When you send the NUI, the DTE or DCE checks the text to determine whether calls can be connected for the user ID you have sent.



In the **X.25** menu use the *SCROLL* key to display the second page of X.25 options:

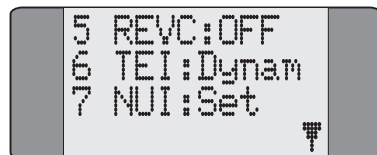



Choose **NUI** from the **X.25** menu to enter a Network User Identifier. The following screen is displayed:



To enter the Network User Identifier you want:

Press the keys repeatedly to insert characters not on the keypad. The characters change as you press the keys:

Network User Identifier entry					
Character	key	Number of Presses	Character	key	Number of Presses
A	2	1	M	6	1
B	2	2	N	6	2
C	2	3	O	6	3
D	3	1	P	7	1
E	3	2	Q	7	2
F	3	3	R	7	3
G	4	1	S	7	4
H	4	2	T	8	1
I	4	3	U	8	2
J	5	1	V	8	3
K	5	2	W	9	1
L	5	3	X	9	2
			Y	9	3
			Z	9	4

When the character you want to add is displayed press the key for the next character you want to add or press .

If you want to enter punctuation or symbols not listed above, press  to scroll through the characters available.

To delete a character, press .

To enter a lowercase character:

Press the appropriate key and display the character you want to add.

Press .

To change the character to lowercase, press the key for the character again.

To add a space press  twice.



Press the *ENTER* key to confirm your choice.

## Connecting a X.25 Call

First you must change **AuroraPlus** to the correct service.

Choose **CALLS** from the Main Menu to display the following screen:

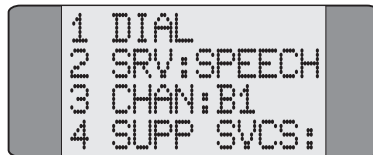

**SRV:** shows the currently selected service. In the above example, **SPEECH** has been chosen.

To change the service type, select **SRV:**. The following screen is the first of a set showing the services available:



An asterisk (\*) is displayed against the currently selected service.



Press the *SCROLL* key repeatedly to scroll through the service screens.



Choose **X.25 d**.

### Connecting a call

Choose **CALLS** from the Main Menu, the following screen is displayed:

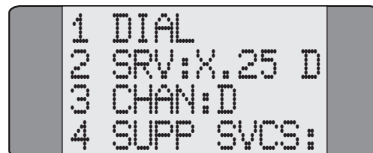

Choose **DIAL**, to display the following screen:

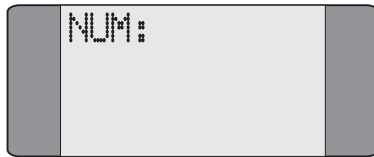

Dial the number you want to call, then press the **ENTER** (↵) key, the following screen is displayed:



To make sure that the DTE (Data Terminal Equipment) and the DCE (Data Circuit-Terminating Equipment) are in the same state **AuroraPlus** (the DTE) sends a restart request to the DCE.



When the restart has been confirmed by the DCE the following screen is displayed:

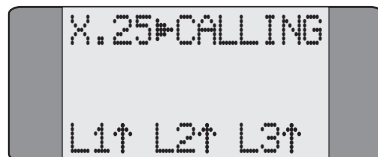

This screen changes when the call is confirmed by the DTE.

```
X.25#CONNECT
RxPkt 0
TxPkt 0
L1↑ L2↑ L3↑
```

To send a packet, press **1**. The number of packets transmitted (TxPkt) is incremented. If a packet is received the number of packets received (RxPkt) is incremented.

### Ending a call

To end the call the *ENTER* ( $\overline{\text{↵}}$ ) key, the following screen is displayed:

```
X.25#CLEARED
Cause 0
Diag -
L1↑ L2↓ L3↓
```

The cause and diagnostic codes are displayed. If there is either no cause or diagnostic code a dash (-) is displayed.

## X.25 Clearing Cause Codes

Code	Reason
1	Number busy
3	Invalid facility request
5	Network congestion
9	Out of order
11	Access barred
13	Not obtainable
17	Remote procedure error
19	Local procedure error
21	RPOA out of order
25	Reverse charge acceptance not subscribed
33	Incompatible destination
41	Fast select acceptance not subscribed
57	Ship absent (maritime service only)

## Receiving X.25 Calls

If **AuroraPlus** is set to X.25 service and an X.25 call is received it is automatically looped back, without changing the content of the call.

When a call is received a screen similar to the following is displayed:

```

X.25 IN:LOOP
RxPkt  11
TxPkt  11
L1↑ L2↑ L3↑
```

To introduce an unexpected packet, press 1.

# Spectrum B Stimulus and Functional (Optional)

## Introduction

This chapter provide describes how to test on a network running Spectrum B Stimulus or Spectrum B Functional using **AuroraPlus**. These features are supplied as an optional feature with **AuroraPlus**.

## SPIDS (Service Profile Identifier)

Spectrum Functional and Spectrum Stimulus both use SPIDS.

The Service Profile of a BRI service is a record in a data base that the switch uses to determine how to serve a specific customer and how to handle specific commands and requests (such as feature keys) from a piece of Customer Premises Equipment.

When the **AuroraPlus** initializes, it sends a message to the switch with the SPIDs for the line.

## Spectrum B Functional

### Bearer and teleservices

Spectrum B Functional supports the following bearer and teleservices:

Tele-ISDN	Telefax Group3	Telefax Group4
Data 64 kbit/s	Telex 64	Telex
3.1k Audio	Mixed Mode	SVideo
PVideo	Videotext	OSI
Timelink	tele-check	

## Supplementary Services

The only supplementary service supported by Spectrum B Functional is the keypad feature. This enables you to send requests to the network to initiate and test the operation of 'stimulus' controlled supplementary services. For information on how to use the keypad feature, see Chapter 4 of this *User Guide*.

## Spectrum B Stimulus and Functional

### Main Menu

When you switch on **AuroraPlus** the following is displayed:



To continue with same SPID (Service Profile Identifier), choose **CONTINUE**, the following is displayed:

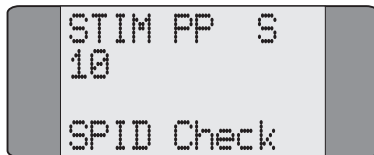

**AuroraPlus** sends the SPID, and when the network responds the following is displayed:







Press the *ENTER* key, if the SPID has been accepted by the network the Main menu is displayed:

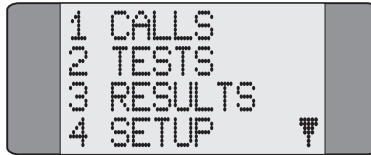

If the SPID has not been accepted by the network, the following screen is displayed:

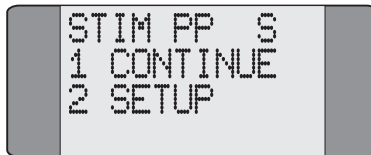

## Changing the SPID (Service Profile Identifier)

You can change the SPID that is sent to the network:

When you choose **SETUP** from the Main Menu the following is displayed:

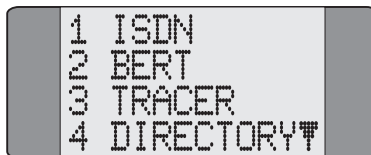

Choose **ISDN**, the following is displayed:

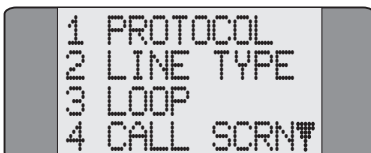



Press the *SCROLL* key from the **ISDN Setup** screen to display further options:



Choose **SPID**, the following is displayed:

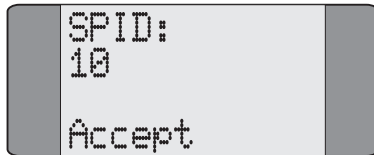

If the SPID has not been accepted by the network **NotSent** is displayed on this screen

Enter the new SPID you want to use, the following is displayed:

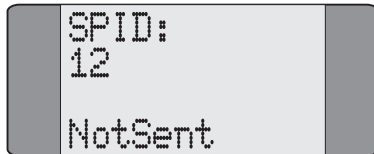

To send the SPID to the network, press *ENTER*, the following is displayed:

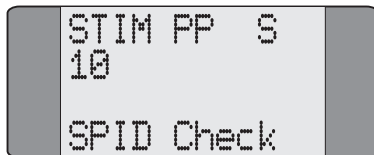

If the SPID is accepted by the network the following is displayed:



To display the Main menu, press the *ENTER* key.

If the SPID is not accepted by the network **SPID Reject** is displayed, or if there is a layer 1 error **SPID Lost** is displayed.



Press the *ENTER* key, the following is displayed:

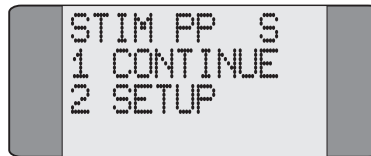

## Spectrum Stimulus Call Setup

On the main menu, choose **CALLS**, the following is displayed:

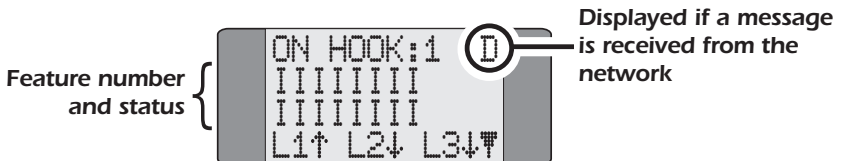

The feature number and the status of the features is displayed:

I	idle
A	Active
?	Prompt
P	Pending

To move around the feature screen and activate a feature:



Press *CLEAR* to move the cursor left through the feature list.



Press *SHIFT* and *CLEAR* to move the cursor right through the feature list.



Press *SHIFT* and *SCROLL* to move up and down the feature list.



Press *ENTER* to send the feature you have selected.

## Performing a BER test

When a call has been established you can perform a BER test.



From the Feature screen, press *SCROLL*, the following is displayed:



If **AuroraPlus** has received a message from the network, **D** is displayed at the top of the screen. If the status of a feature has changed, **F** is displayed.

To start the BER test, choose **BERT**.

## Viewing messages sent by the network

**AuroraPlus** displays 2 lines of 24 character messages sent by the network, to view messages:



From the Feature screen, press *SCROLL* twice, the following is displayed:

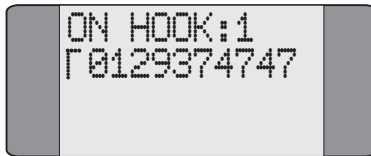

If the second line of the message is being displayed, **L** is displayed at the beginning of the line.



# Testing on Analogue Lines with AuroraPlus (Optional)

This chapter describes how to use **AuroraPlus** to make calls and test on analogue networks. Also described is how to perform a 40kHz Test to measure signal loss.



## Note

Analogue is sometimes referred to as 'POTS' (Plain Old Telephone Service).

## Preparing AuroraPlus for Analogue Lines

- Set the *ISDN ANALOG/POTS* Switch to the *ANALOG/POTS* position.
- Place the *S/U* Switch in the *DOWN* position.
- Switch **AuroraPlus** off and on, using the *CHARGE/BAT* Switch, to re-initialise the unit and apply the settings.
- Connect the two 4mm 'banana' plugs to the line directly or via the 'crocodile' clips supplied.

The Analogue Main Menu is displayed:

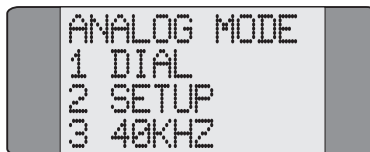

## Note

This menu is shown only when you have purchased the analogue feature for your **AuroraPlus**. On battery units which do not have analogue testing ability, when you select analogue mode the 40kHz Generation Test screen is displayed. For details, see later in this chapter.

## Analogue Setup

You can set the following parameters for analogue mode:

- Dial Mode (i.e. DTMF or Pulse)
- Speed Dial numbers
- Language for the user interface
- Loudspeaker volume setting

Choose **SETUP** from the Analogue Main Menu to display the following screen:

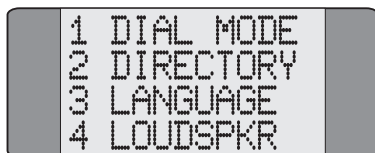

### Setting the Dial Mode

To set the Dial Mode, choose **DIAL MODE** from the **SETUP** Menu to display the following screen:

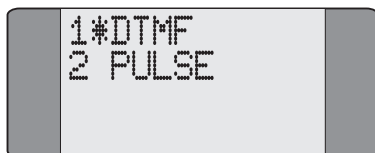

Select either **DTMF** or **PULSE** dialling. An asterisk (\*) is displayed against the current selection.

### Storing Speed Dial Numbers

Choose **DIRECTORY** from the **SETUP** Menu. You enter and save Speed Dial numbers in exactly the same way as for ISDN. Please refer to the appropriate section in Chapter 3 for further information.



## Setting Language & Loudspeaker Options

Choose either **language** or **loudspkr** from the **SETUP** Menu to set the language or loudspeaker options. The setting of these options is exactly the same as for ISDN. Please refer to the appropriate sections in Chapter 3 for further information.

## Answering Incoming Calls

An incoming call is indicated by the ringer sounding. If **AuroraPlus** is currently displaying the Analogue Main Menu, press the **ENTER** () key.



Press the **ENTER** () key to accept the call.

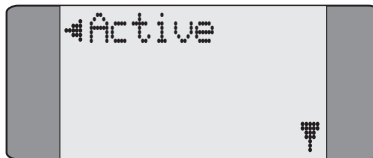

When the call is active, you can switch between DTMF and Pulse dialling, or put the call on hold - for instructions, see later in this chapter.

## Making Outgoing Calls

There are two ways in which you can dial a number for an outgoing call:

- Overlap mode: digits are sent one at a time
- En bloc mode: all the digits you dial are sent together as a group

### Overlap Dialling

To dial in Overlap mode, select **DIAL** from the Analogue Main Menu.



Now press the *ENTER* (↵) key.



Dial the number.



The dialled subscriber is called. When answered, the call is connected.



Press the **ENTER** (↵) key to terminate the call.

The main Analogue menu is displayed.

If you have chosen to display the number of meter pulses you have received for an outgoing call, the information is displayed on this screen. For details, see *Displaying the Meter Pulse Count* later in this chapter.

## En Bloc Dialling



To dial in En Bloc mode, you enter the number and then press the **ENTER** (↵) key to dial.

From the Dial Screen, enter the number you wish to dial (or use Call Redial or Speed Dialling).

You can insert a 'Pause' (e.g. a pause between an area code and a subscriber number) by pressing + . This is displayed as a 'P' symbol in the number.

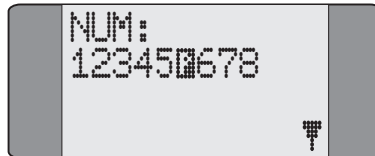

### Tip

To erase the most recently entered digit, press the **CLEAR** key.



Now press the **ENTER** () key. A dial tone is heard and the number is dialled. When answered, the call is connected.

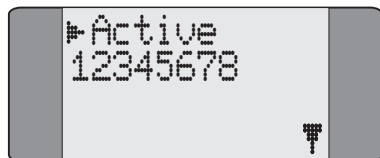

## Speed Dialling

Speed Dialling allows you to recall and dial previously stored numbers. You enter and save Speed Dial numbers in exactly the same way as for ISDN - please refer to *Storing Speed Dial Numbers* in Chapter 3 for further information.



In the Dial Screen, to recall a Speed Dial number, press **SHIFT** followed by the number (0-4) of the memory location containing the CPN you wish to dial. For example, to dial the number held in Speed Dial memory location 3, press  + 3.

**AuroraPlus** displays the number you have chosen.

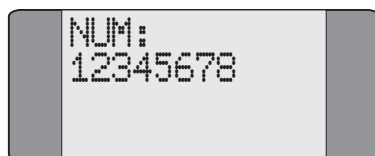

Now press **ENTER** () to dial the number.

## While a call is connected

During an analogue call, you can switch between Pulse and DTMF dialling, or put the call on hold and make a second call. For outgoing calls, you can also choose whether to display the meter pulses received (charge information) either during or after the call.

## Switching between Pulse and DTMF dialling

You can change the dialling type during a call - you might do this when you are calling through a network to equipment which uses a different dialling mode.



Press **SCROLL** to display the options for a connected call.



If the current dial mode is DTMF, you can choose **PULSE** from this screen to switch to pulse dialling, as in the above illustration. If the current mode is Pulse, you can choose **DTMF**.

**AuroraPlus** displays a screen for you to enter a number using the new dial mode.



- ▼ To return to the connected call options menu, press the **SCROLL** key. Notice that the dial mode option has changed to let you switch back to the original mode. For example, if you have switched to Pulse dialling, **AuroraPlus** now displays a **DTMF** option, and vice versa.

## Putting a call on hold

You can place an existing analogue call on hold and make a second call, then return to the original call.



### Note

This feature is only available on an analogue PBX with tone dialling and flash signalling which uses Timed Break Recall.

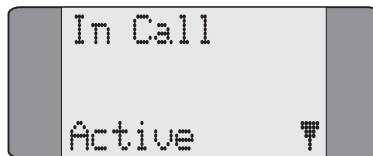

Press **SCROLL** to display the options for a connected call.



Choose **RECALL** to send a flash signal placing the original call on hold. **AuroraPlus** displays a screen for you to dial the number for the new call.

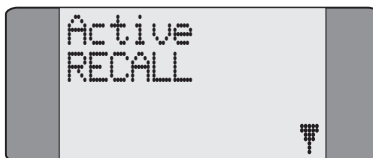

Dial the number. When you have entered a valid number, **AuroraPlus** connects the new call.



Press **SCROLL** to return to the connected call options screen.

To clear this call and reconnect to the original call, choose **RECALL**



**Note**

On an internal analogue network, you may have to press another key, specific to that network, after choosing **RECALL**.

## Displaying the Meter Pulse Count



During an outgoing call, you can choose whether to display the number of meter pulses received, to find out how much you have been charged for the call.



**Note**

Call Charge Display (Facility Code 67 - see Chapter 5) must be enabled before you can display meter pulses.



Press **SHIFT** and **0** to display the current meter pulse count.

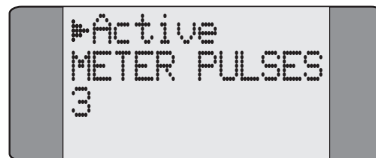

Press **CLEAR** to remove the meter pulse display.

At the end of the call, if the meter pulse display is currently on, **AuroraPlus** displays the final meter pulse count for the call.



## The 40kHz Generation Test

The 40kHz Test is used to send a 40kHz tone at -12dB (-17dBm ) across the line from the remote end. This can be used by a tester at the exchange (a TIMS tester) to measure signal loss. This test may be used on the 2 Wire Interface only.



### Note

To perform the 40kHz Test you must place **AuroraPlus** in analogue mode, regardless of whether you have purchased this feature or not. The 40kHz Test is only available on units with a built-in battery.

Choose **40kHz** from the Analogue Main Menu.

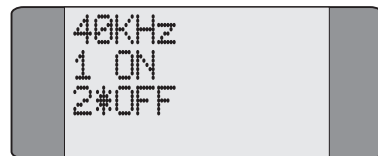

Choose **ON** to send the tone. **AuroraPlus** continues to send the tone until **OFF** is selected.



### Note

You cannot leave the 40kHz screen until you have turned the tone off.



This appendix provides technical information about your **AuroraPlus**.

## U Interface

*Transmission Method* 2-wire transmission with echo compensation

*Channel Structure* 2B+D, synchronisation and service data

### **Line Code 4B3T (MMS 43):**

*Transmission Rate* 120 kBd

*Net Data Rate* 144 kbps

### **Line Code 2B1Q:**

*Transmission Rate* 80 kBd

*Net Data Rate* 144 kbps

*Power Status Bit* PS1, PS2 normal (11)

*Interface Maintenance Mode* Integrated

*Supply Concept* Powersource 1 and Powersource 2 in accordance with CCITT 1.430, or internal battery

*Operating Power Consumption* Less than 500mW

## S Interface

*Transmission Method* Passive 4-wire line bus

*Channel Structure* 2B+D, synchronisation and monitoring

*Line Code* AMI (modified)

*Total Bit Rate* 192 kbps

*Useful Bit Rate* 144 kbps

*Range* Approx. 150 m for passive bus installation

*Supply Concept* Powersource normal or restricted in accordance with CCITT I.430, or internal battery

*Operating Power Consumption* Less than or equal to 380 mW

## **Acoustic Data**

*Sending Loudness Rating* 7 dB  $\pm$ 3.5

*Receiving Loudness Rating* (RLR) 3 dB  $\pm$ 3.5

*Sidetone Masking Rating* (STMR) 13 to 18 dB

## **Protocols**

*Layer 1* ETS 300 012

*Layer 2* ETS 300 402

*Layer 3* ETS 300 403

*Multiple Subscriber Number (MSN)* ETS 300 052

*Direct Dial In* ETS 300 064

*Calling Line Identification Presentation (CLIP)* ETS 300 092

*Subaddressing (SUB)* ETS 300 061

*Call Forwarding (CF)* ETS 300 207

*Call Waiting (CW)* ETS 300 058

*Call Hold (HOLD)* ETS 300 141

*Three Party Call (3PTY)* ETS 300 188

*MCID* ETS 300 130

Optional: FTZ 1TR6

## Analogue Interface

<i>DC Isolation</i>	1 M ohm @ 105 V DC
<i>Ring Frequency Detection</i>	13 to 70 Hz
<i>Pulse Dialling</i>	
<i>Make/Break Period</i>	40/60 ms or 33/66 ms (internal configuration)
<i>Inter Digit Pause</i>	840 ms
<i>DTMF (Touch Tone) Level</i>	-6/-8 or -9/-11 dBm (region-specific)
<i>Flash Time</i>	100, 300 or 600 ms (region-specific)
<i>Access Pause</i>	3 seconds
<i>Return Loss</i>	More than or equal to 10dB
<i>DC-Mask</i>	Less than or equal to 400 ohms at 20 mA
<i>40 kHz Generation Test</i>	at -12 dB (-17dBm)

## Acoustic Data

<i>Sending Loudness Rating</i>	+4 ±3dB
<i>Receiving Loudness Rating</i>	-7 ±3dB

## Polarity Test

<i>DC-Resistance</i>	More than or equal to 1 M ohm (AD-Converter)
----------------------	-------------------------------------------------

## Ambient Temperature

<i>Storage/Transport</i>	-25°C to +75°C
<i>Operation</i>	-5°C to +55°C

## Dimensions

<i>Weight</i>	approx. 540 g
---------------	---------------

## Connecting cables

*U Connecting Cable*

Length approx. 2 m, two 4 mm 'banana' plugs

*S Connecting Cable*

Length approx. 2 m, RJ45 modular plug

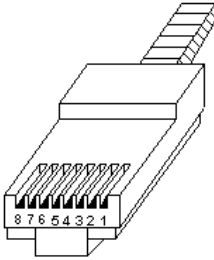

### S connecting cable

#### ISDN Basic Rate Connector and Pin Assignments

Pin	NT	TE
<b>1</b>	Not connected	Not connected
<b>2</b>	Not connected	Not connected
<b>3</b>	Tx (+)	Rx (+)
<b>4</b>	Rx (+)	Tx (+)
<b>5</b>	Rx (-)	Tx (-)
<b>6</b>	Tx (-)	Rx (-)
<b>7</b>	Power Sink 2 (-)	Power Source 2 (-)
<b>8</b>	Power Sink 2 (+)	Power Source 2 (+)

## U connecting cable

ISDN Basic Rate Connector and Pin Assignments		
Pin	NT	TE
1	Tx/Rx	Tx/Rx
2	Tx/Rx	Tx/Rx
3	Not connected	Not connected
4	Not connected	Not connected
5	Not connected	Not connected
6	Not connected	Not connected
7	Not connected	Not connected
8	Not connected	Not connected

### 8 pin mini DIN cable:

Viewed from the wire direction

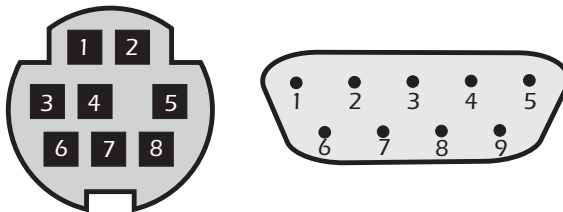

8 pin mini din socket to 9 way D female

- pin 1 connected to pins 1, 6 and 8
- pin 2 connected to pin 7
- pin 3 (Tx) connected to pin 2 (Rx)
- pin 4 connected to pin 5
- pin 5 (Rx) connected to pin 3 (Tx)

## **Layer 3 Service Setting Information Elements**

The following table lists information about ISDN service settings, for outgoing calls, which is passed to the network.

Display	DSS 1					
	BC Bearer Capacity		HLC High Layer Compatibility		LLC Low Layer Compatibility	
TEL-ISDN	80 90 A3	speech 64 kbit/s G.711, A-law	91 81	first hlc Telephony		
3.1K.AUD	90 90 A3	3,1 kHz audio 64 kbit/s G.711, A-law				
DATA 64	88 90	unrestricted 64 kbit/s				
FAXGRP3	90 90 A3	3,1 kHz audio 64 kbit/s G.711, A-law	91 84	first hlc Fax Gr.2/3		
FAXGRP4	88 90	unrestricted 64 kbit/s	91 A1	first hlc Fax Gr. 4	88 90 D1 E7	unrestricted 64 kbit/s ISO 7776 ISO 8208
TELETEX64	88 90	unrestricted 64 kbit/s	91 B1	first hlc Teletex F.200	88 90 D1 E7	unrestricted 64 kbit/s ISO 7776 ISO 8208
X.21 UC4	88 90	unrestricted 64 kbit/s			88 90 21 83	unrestricted 64 kbit/s V.110/X.30 2,4 kbit/s
X.25 UC8	88 90	unrestricted 64 kbit/s			88 90 21 83 C6 E6	unrestricted 64 kbit/s V.110/X.30 2,4 kbit/s X.25 link X.25 packet
BTX	88 90	unrestricted 64 kbit/s			88 90 D1 EA	unrestricted 64 kbit/s ISO 7776 T.70
BTX NEW	88 90	unrestricted 64 kbit/s	91 B2	first hlc BTX New	88 90 D1 E7	unrestricted 64 kbit/s ISO 7776 ISO 8208
AUDIO VIS	91 90 A5	unrestricted with tones and announcements 64 kbit/s G.722/G.725	91 E0	first hlc (F.720)		
REM CONT	88 90	unrestricted 64 kbit/s				
GRAPHTEL	88 90	unrestricted 64 kbit/s				
MIX MODE	88 90	unrestricted 64 kbit/s	91 A4	first hlc F.230	88 90 D1 E7	unrestricted 64 kbit/s ISO 7776 ISO 8208





# Glossary and Acronyms

## Symbols

**1TR6** 1TR6 is the national protocol for the ISDN environment in Germany. It is also often used in private networks utilising equipment of German origin.

**2B+D** Two B-channels and one D-channel, an alternative way of referring to the Basic Rate Interface.

## A

**A-law** Companding technique for Pulse Code Modulation, used in Europe.

**Address** The digits that identify the origin and/or the destination of a data communications message.

**ARCOFI** Audio ring codec filter.

**ASCII** American Standard Code for Information Interchange. The US version of the ISO 7-bit data code. Usually transmitted in 8-bit characters, the additional bit being an odd or even parity bit.

**Asynchronous** The description used for a communications channel capable of transmitting data but not timing.

**AuroraExpert** A protocol analysis package that can be used in conjunction with the **Aurora** family of ISDN testers.

## B

**B1** The first bearer channel on a BRI connection.

**B2** The second bearer channel on a BRI connection.

**BX** A convention to indicate *either* B-channel (B1 or B2).

<b>B Channel</b>	Bearer channel. ISDN utilises multiplexed channels that are transmitted over the same physical medium. The B channels typically carry the user's voice/data/video.
<b>Basic Rate Interface (BRI)</b>	An ISDN configuration that uses a standard 2-wire telephone line to provide two B-channels at 64 kbps and one D-channel at 16 kbps.
<b>Bearer service</b>	The types of service (such as voice, data, facsimile, etc.) that the B-channel can carry. Also called bearer capability (BC).
<b>BER</b>	Bit Error Ratio/Rate. A measure of transmission quality: the number of errored bits divided by the total number of bits transmitted in a specific interval.
<b>Bit Error Rate Test (BERT)</b>	A test that sends a pattern of bits on a data line and then compares the bits received to the bits that were sent to detect any errors.
<b>BRI</b>	Basic Rate ISDN.
<b>Bus</b>	An electrical path providing a connection for a group of devices.

## C

<b>Call screening</b>	A facility that enables a telephone to respond differently to an incoming call, depending on the number that was called (CPN) or the number of the caller (CLI).
<b>Call waiting</b>	A telephone service that allows a call to a busy telephone to be held while the busy telephone is notified that a second call is waiting.

<b>Called party subaddress (CPN-SUB)</b>	The subaddress of the called party. This is included in the outgoing setup message when en bloc dialling is used.
<b>Calling party subaddress (CLI-SUB)</b>	The subaddress, if any, of the calling party.
<b>CCITT</b>	The former name of the ITU-T (from French acronym).
<b>Central Office (CO)</b>	A US term for a telephone exchange.
<b>Channel</b>	A path (either physical or logical) for transmission of information.
<b>Clear Cause</b>	A code indicating the reason why a call has cleared.
<b>CLI</b>	Calling Line Identity. The number belonging to the caller.
<b>Closed User Group (CUG)</b>	In an X.25 network, a group of subscribers that are configured such that calls to and from the group are restricted.
<b>CPN</b>	Called Party Number. The number dialled by the calling party.

## D

<b>D Channel</b>	An ISDN channel that supports signalling or packet data at speeds of 16 kbps (BRI) or 64 kbps (PRI).
<b>Data</b>	Digital information, which may be text, voice or video.
<b>Decode</b>	This is ISDN signalling information from the D Channel. Decode can be captured in <b>AuroraPlus</b> 's memory using the Tracer feature.
<b>Digital Exchange</b>	An exchange that switches digital signals by means of digital switching.

**DTMF**  
**(Dual Tone**  
**Multifrequency)** A telephone signalling method in which each key generates two audio tones.

## **E**

**EAZ** The subscriber number for a line using 1TR6 consists of a fixed part which is common to the line and a digit which identifies the terminal—this is the EAZ. The abbreviation comes from the German word for ‘end equipment selection number’. Sometimes called a 1TR6 ‘subaddress’.

**En Bloc** A dialling method whereby the user enters the entire destination number and it is sent as a whole in the call setup.

**Encoding** The process of coding information into a form suitable for transmission.

**End to End** Signalling method in which signals pass right through from end to end without processing within intermediate nodes.

**EOC** Embedded Operations Channel on the U interface. Used to send commands from the switch to the NT, to perform activities such as a loopback within the NT.

**EPROM** Erasable Programmable Read Only Memory.

**Error rate** The relationship between the number of incorrectly received bits or blocks to the total number of bits or blocks transmitted.

**ES** Errored Second. A second in which one or more CRC (Cyclic Redundancy Check) violations are measured in a single direction of transmission.

**ETSI** ETSI stands for 'European Telecom Standards Institute', which is the standards making authority for Europe. The ITU Q921 and Q931 recommendations are commonly referred to as the ETSI protocol or DSS1.

## F

**Far-end block errors (FEBE)** The number of errors detected in transmitted data blocks at the destination (remote) end.

**Fixed Link** A type of ISDN Point-to-Point link which does not use protocol transactions to establish a clear channel.

**Flash** A momentary interruption in the supervisory signal of a telephone call. A user can obtain this result by pressing the hook key.

**Flash memory** A type of EPROM that can be erased electrically, holds the **AuroraPlus** software.

## H

**High Layer Compatibility (HLC)** A way of identifying an ISDN tele-service (e.g. speech, Group 4 fax, etc.)

**Hook** () A key on the **AuroraPlus** keypad that is used to provide on-hook (deactivation) and off-hook (activation) functions.

**Hot key** A sequence of two or more keys that provides a short-cut method of accessing a particular function. On the **AuroraPlus**, hot key sequences consist of the *SHIFT* key plus another key.

## I

**Integrated Services Digital Network (ISDN)** A telecommunications network designed to transmit and process all types of voice and data traffic using digital transmission and switching.

**ITU** International Telecommunications Union.

## L

**Layer** In the OSI model, a layer is a collection of related functions within a communications system with a defined service interface to layers above and below.

**LCD** A Liquid Crystal Display, such as the screen on **AuroraPlus**.

**LED** Light Emitting Diode.

**Logical Channel Number (LCN)** A means of identifying the data link that is used across an X.25 network to connect the source and the destination.

**Loopback** Data received on the Rx channel of a circuit is re-transmitted on the Tx channel of the same circuit.

**Low Level Compatibility (LLC)** The service provided at the lower layers.

## M

**MHS** Message Handling System

**Modem** A device which converts digital signals into analogue tones which can be passed through the telephone network. A modem at the receiving end reverses this process to recreate the original digital signal.

**Multiple Subscriber** A supplementary service available on Point-to

- Number (MSN)** -Multipoint lines, which allows terminal selection based on CPN (Called Party Number).
- $\mu$ -law** A companding technique used for PCM systems in North America, Japan and some other regions in Asia.

## N

- Near-end block errors (NEBE)** The number of errors detected in transmitted data blocks at the originating end.
- Network termination (NT)** A piece of equipment that terminates an ISDN connection at the customer premises. The NT1 terminates the physical interface from the central office at the customer premises. The NT2 is an intelligent device at the customer premises that can provide functions such as switching and concentration. The NT1 and NT2 are sometimes physically combined and called the NT. NT1 provides the T reference point (T interface), and NT2 provides the S reference point (S interface).

## O

- Off hook** A line state which informs the exchange (Central Office) that a subscriber requires a service.
- On hook** The unused state of a telephone circuit.
- OSI 7-layer Model** A model defined by the ISO, in which ISDN functions are separated into 7 clearly defined layers.
- Overlap dialling** A type of dialling where the digits are sent one at a time, each in its own separate call control message.

## **P**

<b>PABX</b>	Private Automatic Branch Exchange. Consists of a number of ‘extension lines’ connected to a central switching system. Users on these extensions can make calls to each other. ‘Exchange lines’ connect the PABX to the local public exchange, allowing the extension users access to the Public Switched Telephone Network (PSTN) or ISDN.
<b>Packet switching</b>	A data transmission method that sends addressed packets over physical and logical links. The physical link is used only for the amount of time needed to transmit the packet. Also called X.25.
<b>PC</b>	Personal Computer.
<b>PCM</b>	Pulse Code Modulation.
<b>Physical Layer</b>	The lowest layer of the OSI model, which is responsible for the electrical, mechanical and interface aspects of transmitted data. Also known as Layer 1.
<b>PMP</b>	Point-to-Multipoint.
<b>Point-to-Multipoint</b>	In Point-to-Multipoint mode (Layer 1) up to 8 terminals can be connected in parallel along the bus. The length of the bus is limited to about 200m, depending on the cable. Multiple TEIs can exist on Layer 2,
<b>Point-to-Point</b>	In Point-to-Point mode one Terminal Equipment (TE) is connected at the end of up to 1km of cable. Only one TEI can exist on Layer 2.
<b>Polarity</b>	The positive or negative state of an electrical connection.
<b>POTS (Plain Old Telephone Service)</b>	Standard analogue telephone service.



<b>PP</b>	Point-to-Point.
<b>PRI</b>	Primary Rate ISDN.
<b>Primary Rate Interface</b>	An ISDN configuration that provides 30 B-channels and one D-channel, all at 64 kbps.
<b>Protocol</b>	A set of procedures or conventions used to standardise data transmissions.
<b>PSPDN</b>	Packet Switched Public Data Network.
<b>PSTN</b>	Public Switched Telephone Network.
<b>PTO</b>	Public Telecommunications Operator.
<b>Pulse</b>	A method of sending dialled digits to the exchange using brief loop current interruptions.
<b>Pulse Code Modulation</b>	A method of converting analogue signals into digital signals.

## R

<b>R interface (R reference point)</b>	In an ISDN, the interface between TE2 and TE1.
<b>Recommendation X.25</b>	The ITU publication that defines the interface between user equipment and a packet switched network.
<b>Redial</b>	A dialling method in which the device automatically redials the last dialled number.
<b>Redirection</b>	The sending of a call to an alternative destination when the intended destination is busy.
<b>Reverse charging</b>	The placing of a data or voice call such that the destination is charged for the cost of the call.
<b>Ringback</b>	The signal fed back to a caller to indicate that the called telephone is ringing.

- RJ-11** The standard modular jack used with a single-line telephone.
- RJ-45** An 8-pin data modular jack.

## S

- S interface** The Point-to-Multipoint interface between the NT1 and the TA or between the NT2 and the TE1. Allows bus operation.
- SAPI** Service Access Point Identifier. Identifies the service for which the frame is intended.
- S/T interface** When the NT1 and the NT2 are physically combined, the S and T interfaces are referred to jointly as the S/T interface.
- Service Profile Identifier (SPID)** A number, based on your equipment's directory number, that is used to identify the equipment on the bus.
- Speed dial** The use of a one-digit code to replace a standard destination address.
- Subaddress** A two, three, or four-digit field appended to the address and used to identify a particular device attached to the S-bus in an ISDN BRI configuration.

## T

- T interface** The Point-to-Point interface between the NT1 and the NT2.
- Terminal adapter (TA)** A type of TE1 device that provides the interface between the NT1 and the TE2.

<b>Terminal equipment (TE)</b>	End-user equipment that is part of an ISDN configuration. A TE1 is equipment that is directly compatible with the ISDN network. A TE2 is equipment that is not directly compatible with the ISDN network.
<b>TEI</b>	Terminal Endpoint Identifier. A unique identity given to the terminal by the network (between 64 and approximately 126), or fixed by the TE (between 0 and 63).
<b>Teleservice</b>	A type of telecommunication service that provides the complete capability, including terminal equipment functions, for communication between users according to protocols established by agreement between administrations and/or telecoms providers.
<b>Teletex</b>	Data transmission standard designed for transmission of word-processed documents.
<b>Terminator</b>	A resistor connected across the ends of a transmission line to provide a constant impedance, to reduce reflection and distortion of signals travelling down the transmission line.
<b>TNV</b>	Telecommunications Network Voltage circuit. A test circuit for definition of safety in a telecoms system.
<b>Tracer</b>	The name given to the <b>AuroraPlus</b> function which lets you capture ISDN signalling information from the D Channel to <b>AuroraPlus</b> 's memory. This information is often termed 'decode'.
<b>Twisted pair</b>	Cable in which a pair of wires are twisted around each other, to minimise noise from other circuits.
<b>Tx</b>	Transmit.

## **U**

### **U interface**

The demarcation point between the customer premises equipment and the ISDN line from the exchange.

## **V**

### **VN1**

VN is the national ISDN protocol for France and it is also used in private networks utilising equipment of French origin.

### **Video text**

Usually refers to an interactive communication application in which a user can communicate with a video terminal.

## **X**

### **X.25**

An internationally recognized standard for transmitting packet switched data.

## ISDN

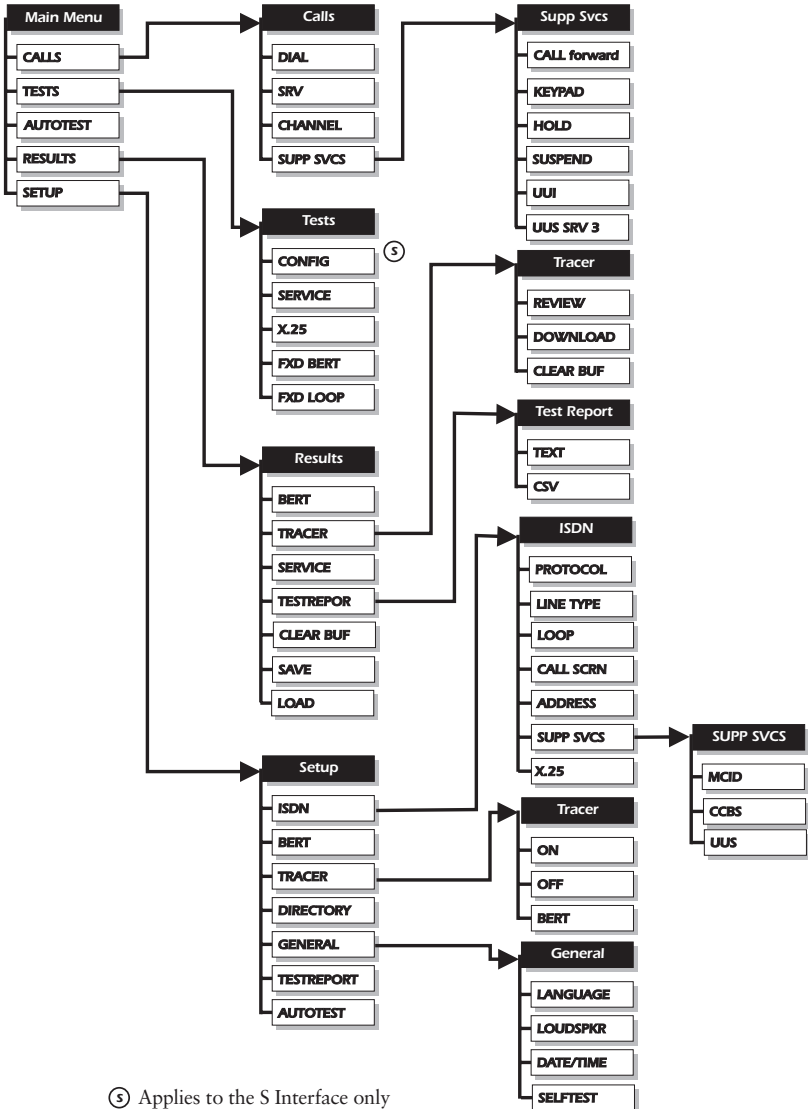

# ANALOGUE

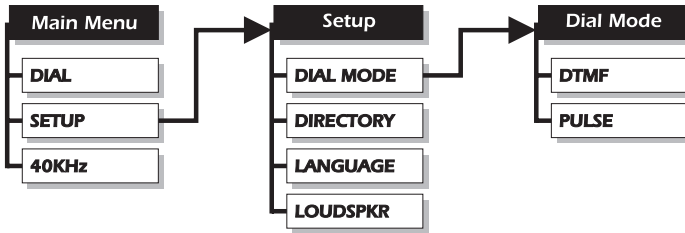

# Call Clearing Cause Codes

This Appendix explains the Cause Codes generated by the remote user or the exchange to which your equipment is connected. Also explained is the fault location information provided by **AuroraPlus**.



## Note

The Appendix does not cover codes higher than 127. These are generated by **AuroraPlus** itself and are used by Trend Communications Ltd. for internal diagnostics. You can normally ignore these codes: however, if they occur frequently you should consult your Trend dealer or call the International Help Desk for further assistance.

## Cause Codes ETSI VN

### Cause

#### Number

#### Cause

- |   |                                                                                                                                                           |
|---|-----------------------------------------------------------------------------------------------------------------------------------------------------------|
| 1 | <i>Unallocated (unassigned) number</i><br>This indicates that the requested destination, although valid, cannot be reached.                               |
| 2 | <i>No route to specified transit network</i><br>Sending equipment (sending the cause) is requested to route call through an unrecognised transit network. |
| 3 | <i>No route to destination</i><br>The called user cannot be reached because the network does not serve the destination.                                   |
| 6 | <i>Channel unacceptable</i><br>The last identified channel is not acceptable to the sending entity.                                                       |

- 7**     *Call awarded and being delivered in an established channel*  
The incoming call is connected to a channel already established for similar calls (e.g. packet-mode X.25 virtual calls).
- 16**    *Normal call clearing (peer)*  
This call is being cleared by one of the users involved.
- 17**    *User busy*  
The called user cannot accept another call although compatibility is established.
- 18**    *No user responding*  
Used when a user does not respond to call establishment messages with either an alerting or connect indication within the allowed time.
- ETSI** **19**    *No answer from user (user alerted)*  
The user has provided an alerting indication but has not provided a connect indication within the allowed time.
- VN** **19**    *Not registered to supplementary service*
- 21**    *Call rejected*  
Equipment sending the cause does not wish to accept this call although the equipment is not busy or incompatible.
- 22**    *Number changed*  
This indicates that the called party number is not assigned.
- VN** **24**    *Unassigned number*
- 26**    *Non-selected user clearing*  
The user has not been awarded the incoming call.



- 27**    *Destination out of order*  
The destination interface is not functioning correctly.
- 28**    *Invalid number format*  
The called party number is invalid, or incomplete.
- 29**    *Facility rejected*  
The network cannot provide the facility requested.
- 30**    *Response to STATUS ENQUIRY*  
This indicates that the reason for generating the **STATUS** message was the prior receipt of a **STATUS ENQUIRY** message.
- 31**    *Normal, unspecified*  
Used to report normal events only when no other cause in the normal class applies.
- 34**    *No circuit/channel available*  
An appropriate circuit/channel is not currently available to handle the call.
- 38**    *Network out of order*  
The network is not functioning. Immediate redial is unlikely to be successful.
- 41**    *Temporary failure*  
The network is not functioning. Immediate redial is likely to be successful.
- 42**    *Switching equipment congestion*  
The switching equipment generating this cause is experiencing a period of high traffic.

- 43** *Access information discarded*  
The network could not deliver access information to the remote user as requested: i.e. a user-to-user information, low layer compatibility, high layer compatibility, or subaddress as indicated in the diagnostic. The particular type of discarded access information is optionally included in the diagnostic.
- 44** *Requested circuit/channel not available*  
This cause is returned when the circuit (or channel) indicated by the requesting entity cannot be provided by the other side of the interface.
- 47** *Resources unavailable, unspecified*  
This reports a resource unavailable event only when no other cause in the resource unavailable class applies.
- ETSI** **49** *Quality of service unavailable*  
This reports that throughput or transit delay cannot be supported and that the Quality of Service (as defined in Recommendation X.213) cannot be provided.
- VN** **49** *User to User information not transmitted*
- 50** *Requested facility not subscribed*  
This indicates that the requested supplementary service could not be provided by the network because the user has not completed the necessary administrative arrangements with its supporting networks.
- 57** *Bearer capability not authorised*  
This indicates that the user is trying to make unauthorised use of equipment providing a bearer capability.

- 58** *Bearer capability not presently available*  
This indicates that the user has requested a bearer capability which is implemented by the equipment generating the cause, but it is not available at this time.
- VN** **59** *Call restriction*
- VN** **60** *Terminal Diversion rejected*
- VN** **62** *Service not authorised*
- 63** *Service or option not available, unspecified*  
This reports a service or option not available event only when no other cause in the service or option not available class applies.
- 65** *Bearer capability not implemented*  
The equipment sending this cause does not support the requested bearer capability.
- 66** *Channel type not implemented*  
The equipment sending this cause does not support the requested channel type.
- 69** *Requested facility not implemented*  
The equipment sending this cause does not support the requested supplementary service.
- 70** *Only restricted digital information bearer capability is available*  
One equipment has requested an unrestricted bearer service but the equipment sending this cause only supports the restricted version.
- 79** *Service or option not implemented, unspecified*  
This reports the service (or option) not implemented event only when no other cause in the service (or option) not implemented class applies.

- 81**    *Invalid call reference value*  
A message with a call reference which is not currently in use on the user network interface has been received by the equipment sending the cause.
- 82**    *Identified channel does not exist*  
The equipment sending this cause has received a request to use a channel not activated on the interface for a call.
- 83**    *A suspended call exists, but this call identity does not*  
A call resume has been attempted with a call identity which differs from that in use for any currently suspended call(s).
- 84**    *Call identity in use*  
The network has received a call suspended request. This request contained a call identity (including the null call identity) which is already in use for a suspended call within the domain of interfaces over which this call may be resumed.
- 85**    *No call suspended*  
The network has received a call resume request. This contained a call identity information element that does not indicate any suspended call within the domain of interfaces over which the call may be resumed.
- 86**    *Call having the requested call identity has been cleared*  
The network has received a call resume request. This contained a call identity information element that once indicated a suspended call; the suspended call was cleared while suspended (either by network timeout, or by a remote user).

**88** *Incompatible destination*  
The equipment sending this cause has received a request to establish a call which has low layer compatibility, high layer compatibility, or other compatibility attributes (e.g. data rate) which cannot be handled.

**91** *Invalid transit network selection*

**92** *Invalid supplementary service parameter*

**95** *Invalid message, unspecified*  
This reports an invalid message event only when no other cause in the invalid message class applies.

**96** *Mandatory information element is missing*  
The equipment sending this cause has received a message which is missing an information element which must be present in the message before that message can be processed.

**97** *Message type nonexistent or not implemented*  
The equipment sending this cause has received a message with a message type it does not recognise; either because this is an undefined message, or defined but not implemented by the equipment sending the cause.

**98** *Message not compatible with call state or message type nonexistent or not implemented*  
The equipment sending this cause has received a message which it considers as non-permissible while in the call state; or a **STATUS** message was received indicating an incompatible call state.

**99** *Information element nonexistent or not implemented*

The equipment sending this cause has received a message which includes information elements not recognised because the information element identifier is not defined, or is defined but not implemented by the equipment sending the cause. However, the information element is not required to be present in the message to enable the equipment sending the cause to process the message.

**100** *Invalid information element contents*

The equipment sending this cause has received an information element which it has implemented. However, the sending equipment was not able to implement the code because one or more of the fields were incorrectly coded.

**101** *Message not compatible with call state*

This indicates the received message is incompatible with the call state.

**102** *Recovery on time expiry*

This indicates that a timer has expired and that an associated Q.931 error handling procedure has been initiated.

**VN** **103** *Mandatory information element of incorrect length*

**111** *Protocol error, unspecified*

This reports an error event only when no cause in the protocol error class applies.

**VN** **113** *Bearer service unavailable*

**VN** **114** *End to End information transfer impossible*

**VN** 126 *Switch to conversation mode*

127 *Interworking, unspecified*

This indicates that there has been interworking with a network which does not provide cause codes for its actions. Therefore the precise cause for a message being sent is not known.

## Cause Codes **ITR6**

### Cause

Number	Cause
1	<i>Invalid call reference value</i>
3	<i>Bearer service not implemented</i>
7	<i>Call identity does not exist</i>
8	<i>Call identity in use</i>
10	<i>No channel available</i>
16	<i>Requested facility not implemented</i>
17	<i>Requested facility not subscribed</i>
32	<i>Outgoing calls barred</i>
33	<i>User Access Busy</i>
34	<i>Connection not possible due to CUG (Closed User Group)</i>
35	<i>CUG does not exist</i>
37	<i>Connection not possible</i>
53	<i>Destination not obtainable</i>
56	<i>Number changed</i>

- 57 *Out of order*
- 58 *No user responding*
- 59 *User busy*
- 61 *Incoming calls barred*
- 62 *Call rejected*
- 89 *Network congested*
- 90 *Remote user initiated*
- 112 *Local procedure error*
- 113 *Remote procedure error*
- 114 *Remote user suspended*
- 115 *Remote user resumed*
- 127 *User information discarded locally*

## Clearing Location

When a call is terminated, either normally or as a result of a fault, **AuroraPlus** displays a call clearing cause code together with location and layer status information.

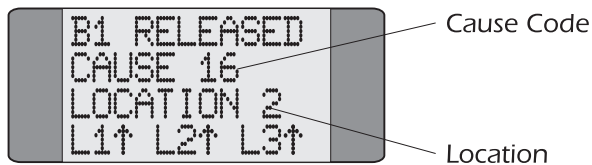

The location value indicates whereabouts in the ISDN the clearing has occurred. There are eight location values and these are explained in the following table:



Location Codes	
Number	Description
0	User
1	Private network serving local user
2	Public network serving local user
3	Transit network
4	Public network serving remote user
5	Private network serving remote user
7	International network
10	Network beyond interworking point

The following diagram illustrates the various locations in the ISDN:

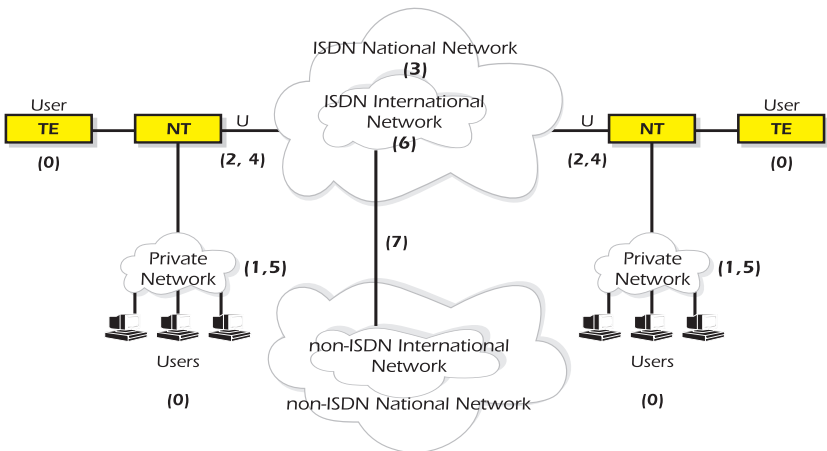

## **Display on termination of call establishment procedure**

- X1** Abort by timer T313, no reply received in response to connect message
- X2** DISC from network received without progress indicator #08
- X3** STATUS message with call state = 0 received
- X4** STATUS message with incompatible call state received
- X5** Layer 2 disconnected by network
- X6** Spontaneous layer 2 reset by network
- X7** RESTART message received
- X8** Abort by timer 303, no reply received in response to setup message

## Symbols

μ-Law 1-13  
2B1Q 1-13, 5-33, A1-1  
3 Party Call 4-37  
40kHz Test 8-10  
4B3T 1-13, A1-1

## A

A-Law 1-12  
Address 3-6  
    setup 3-6  
Analogue Testing 8-1  
    answering incoming calls 8-3  
    changing dial mode during a call 8-7  
    connections 2-10  
    making outgoing calls 8-4  
    meter pulse count 8-9  
    putting a call on hold 8-8  
    setup 8-2  
Answering Incoming Calls 4-7, 8-3  
**AuroraPlus** 1-4  
    features 1-4  
    looking after 1-8  
    powering 2-11  
    status check 5-34  
    technical information A1-1  
    use 1-7  
Automatic Configuration 5-4  
Autotest 5-1  
AWS1 4-21, 5-31  
AWS2 4-21, 5-32

## B

B Channel Selection 4-18  
Backlight, switching on & off 2-12

- Basic Rate 1-13
- Battery Use/Charging 2-6
- Bearer Service
  - High layer compatibility 4-17
  - Low layer compatibility 4-16
  - User-defined 4-14
- BER Test 3-10, 4-3
  - performing 5-8
  - setup 3-10
  - understanding results 5-13
- Bit Error Rate. *See* BER Test
- BRI. *See* Basic Rate

## **C**

- Cables 2-8
- Call 4-1
  - answering 4-7, 8-3
  - clearing 4-5, A4-1
  - connected screen 4-3
  - control options 4-3
  - establishment 4-1
  - redial 4-6
  - retrieving 4-11, 4-12
  - three party call 4-37
- Call Barring 5-32
- Call Charging 5-32
- Call deflection 4-29
- Call Forwarding 4-20
  - status 5-29, 5-31
- Call Hold/Retrieve
  - for analogue calls 8-8
- Call Screening 3-3, 3-5
- Called Party Number. *See* CPN
- Calling Line Identity. *See* CLI
- Capturing Protocol Information 3-12
- Care Advice 1-8
- Cause Codes 4-5, A4-1
- CCBS 4-40
  - Deactivating 4-42
  - Error messages 4-44
  - Making a call 4-41

- CFB 4-20
- CFNR 4-20
- CFU 4-20
- Channel Selection 4-18
- Charging the Battery 2-6
- Clear Key 2-3
- Clearing a Call 4-5
- CLI 3-6
- CLI-SUB 3-6
- Closed User Group 6-3. *See also* CUG
- Communication Ports & Connectors 2-8
- Configuration Check 5-3
- Connected Screen 4-3
- Connecting **AuroraPlus** 2-9–2-14
  - for analogue testing 2-10
  - for ISDN testing 2-10
  - to a PC 2-11
- Conventions 1-2
- CPN 3-6, 4-2
- CPN-SUB 3-6
- CUG 5-32, 6-3
- Customer name
  - adding to a report 5-20

## D

- D Channel X.25 6-1
- Decode 3-12, 5-16
- Defaults 3-17
- Deflection calls 4-29
- Dialling
  - DTMF 8-2
    - en bloc 4-1, 8-5
    - overlap 4-2, 8-4
    - pulse 8-2
- Downloading New Software 5-26
- DTMF
  - sending during calls 4-4
- DTMF dialling 8-2

## **E**

En Bloc Dialling 4-1, 8-5  
Encoding 1-12  
Enter Key 2-3  
ETSI (Euro ISDN) 1-3

## **F**

FAC. *See* Facility Access Code  
Facility Access Code 5-23  
Factory Defaults. *See* Defaults  
Far End Block Errors 5-33  
FEBE. *See* Far End Block Errors  
Fixed Links 3-11, 5-8  
Flash Memory 5-26

## **H**

Help Desk Numbers 1-9  
High layer compatibility 4-17  
Holding a Call 4-9  
Hot Keys 2-4, 2-14

## **I**

Idle Screen 2-11  
Interface Switch 2-7  
Interfaces 1-11, 2-12  
ISDN 1-10–1-19  
ISDN connections 2-10  
ISDN Services 1-10, 4-12, A1-6

## **K**

Keypad Facility 4-30  
    Codes 4-31  
    En-bloc dialling 4-32  
    Not in active call 4-31  
    Overlap dialling 4-33  
Keys 2-3

**L**

- Language Setting 3-15, 8-3
- Layer 3 Service Setting Information A1-6
- Layer Status Information 2-12, 4-5
- LCD 2-2
- LCGN 6-2
- LCN 6-2
- Line Power 2-12
- Line Type 2-12, 5-34
  - selecting 3-2
- Local Service Check 5-5
- Logical Channel Group Numbers 6-2
- Logical Channel Numbers 6-2
- Loop 3-3, 3-10, 4-3, 4-7, 4-8, 5-34
  - setup options 3-4
- Loudspeaker 3-16, 8-3
- Low layer compatibility 4-16

**M**

- Main Menu 2-12
  - returning to the Main Menu 2-14
- Malicious Call Identification 4-36, 5-32
- MCID. *See* Malicious Call Identification
- Menus 2-12
  - diagrams A3-1
  - exiting 2-14
  - scrolling through 2-12
  - selecting from 2-13
- Meter Pulse Count
  - displaying for an analogue call 8-9
- MSN 5-31
- Multiple Subscriber Number. *See* MSN

**N**

- Near End Block Errors 5-33
- NEBE. *See* Near End Block Errors
- Network User Identifier 6-6
- NUI 6-6

## O

- Operator name
  - adding to a report 5-20
- OSI 7-Layer Model 1-15
- Overlap Dialling 4-2, 8-4

## P

- PC
  - connecting to 2-11, 5-26
  - downloading BERT results to 5-9
  - downloading tracer to 5-17
- Plain Old Telephone Service 8-1
- PMP. *See* Point-to-Multipoint
- Point-to-Multipoint 1-14, 3-2, 5-3, 5-34
- Point-to-Point 1-14, 3-2, 5-3, 5-34
- POTS. *See* Plain Old Telephone Service
- Powering On **AuroraPlus** 2-11
- PP. *See* Point-to-Point
- PRI. *See* Primary Rate
- Primary Rate 1-13
- Protocol Information (Tracer Function) 3-12
- Protocols 1-2, 1-18, A1-2
  - AuroraPlus**'s current settings 2-12, 5-34
  - checking on the line under test 5-3
  - selecting 3-1
- Pulse Code Modulation 1-12
- Pulse Dialling 8-2

## R

- Rcognised Packet Operating Agency 6-4
- Redialling 4-6
- Remote Service Check 5-6
- Report
  - sending to a PC 5-20, 5-21
- Results
  - sending to a PC 5-20
- Results, displaying 5-15
- Resuming a call 4-45
- Retrieving a held call 4-11, 4-12



Reverse Charges 6-4  
RPOA 6-4

## S

S/T-interface A1-1  
Safety Advice 1-8  
SAPI 5-7  
Saving results 5-19  
Scroll Key 2-3  
Self Test Functions 5-22–5-29  
Service Check 5-4  
    results 5-6  
service profile 7-1  
Service Profile Identifier 7-1  
Service Setting Information A1-6  
Setting Up **AuroraPlus** 3-1  
Shift Key 2-4  
Software Upgrades 5-26  
Specifications for **AuroraPlus** A1-1  
Spectrum B Functional 7-1  
Spectrum B Stimulus  
    Call setup 7-5  
Spectrum Functional 7-1  
Speed Dialling 3-14, 4-6, 8-6  
    storing numbers 3-14, 8-2  
Status Check 5-34  
Status Request 5-29  
Supplementary Services 4-3, 4-20  
Supplied with **AuroraPlus** 1-8  
Suspending a call 4-44  
Switches 2-4

## T

Technical Data A1-1  
TEI 6-5  
Teleservices 1-5  
    checking on the line under test 5-4  
    selecting 4-12  
Terminal Endpoint Identifier 6-5  
Termination Resistor Switch 2-6

Three Party Call 4-37

clearing 4-39

Tones

sending during calls 4-4

Tracer

clearing from memory 5-18

displaying tracer output 5-16

downloading to a PC 5-17

setup 3-12

Trendsend 5-26

## **U**

U Interface A1-1

User Guide 1-1–1-3

User to user signalling 4-46

Invoke request 4-50

Service 1 4-47

Service 2 4-48

Service 3 4-49

## **V**

Voltage on the Line 2-12

Volume Settings 3-16

## **X**

X.25 calls 6-1

connecting 6-8

diagnostic codes 6-12

ending 6-11

incoming calls 6-12

X.25 Test 5-7