



ABN 43 064 478 842

231 Osborne Avenue Clayton South, VIC 3169
PO Box 1548, Clayton South, VIC 3169
t 03 9265 7400 f 03 9558 0875
freecall 1800 680 680
www.tmgtestequipment.com.au

Test & Measurement

- > sales
- > rentals
- > calibration
- > repair
- > disposal

Complimentary Reference Material

This PDF has been made available as a complimentary service for you to assist in evaluating this model for your testing requirements.

TMG offers a wide range of test equipment solutions, from renting short to long term, buying refurbished and purchasing new. Financing options, such as Financial Rental, and Leasing are also available on application.

TMG will assist if you are unsure whether this model will suit your requirements.

Call TMG if you need to organise repair and/or calibrate your unit.

If you click on the "Click-to-Call" logo below, you can call us for FREE!

TMG Corporate Website

TMG Products Website



Click-to-Call
TMG Now



Product Lifecycle Management System

Disclaimer:

All trademarks appearing within this PDF are trademarks of their respective owners.





403LA

Broadband Power Amplifier



HIGH RF VOLTAGES MAY BE PRESENT AT THE OUTPUT OF THIS UNIT. All operating personnel should use extreme caution in handling these voltages and be thoroughly familiar with this manual.

Do not attempt to operate this unit prior to reading this manual.

The material contained in this document is the property of Electronics & Innovation Ltd., it is subject to change without notice.

Warranty

Electronics & Innovation Ltd., (hereafter E&I) warrants for the period of one year from the date of original delivery, each unit to be free of defects in materials and workmanship. For the period of 12 months E&I will, at its option, repair or replace defective parts so as to render the unit fully operational such that it performs according to the original specifications; free of charge to the original purchaser.

Should warranty service be required, the unit must be returned to E&I, freight cost to be borne by the owner. If, in our opinion, the unit has been damaged by use outside the limits prescribed in this manual or by accident, then the warranty shall not be honored. In such a case E&I will provide an estimate for repair, assuming repair is possible and provide a quote at standard service rates.

Contents

Chapter 1	
General Information.....	3
Chapter 2	
Operation.....	4
Chapter 3	
Technical Information.....	7
Chapter 4	
Maintenance.....	8
Chapter 5	
Safety.....	12

The material contained in this document is the property of Electronics & Innovation Ltd., it is subject to change without notice.

Chapter 1 Introduction

The Model 403LA is a general purpose broadband amplifier capable of more than 3W of linear power output when driven by any laboratory signal or sweep generator from 0.15 to 300 MHz

An ultra linear Class A design, the 403LA will "boost" the output of any signal source by at least a flat 37 dB (± 1 dB) and provide its full forward output power into any load impedance (from an open to a short circuit). Its output is a faithful reproduction of the input waveform for AM, FM, SSB, CATV, pulse and other complex modulations. Although specified only over the 0.15 to 300 MHz frequency range, full power output is typically available from 0.1 to 320 MHz.

The use of RF DMoS transistors with microstrip circuitry ensures that the 403LA is both a reliable and rugged source of RF power. An integral power supply and cooling system permit operation over a wide range of temperature and AC line conditions.

1.2 INSTRUMENTATION IDENTIFICATION

Each amplifier is identified by a serial number tag on the back panel of the unit. Both the model number and the serial number should be quoted to identify a specific unit. As shown below:



The material contained in this document is the property of Electronics & Innovation Ltd., it is subject to change without notice.

1.3 SPECIFICATIONS

Physical and electrical specifications are listed in Table 1 below:

Frequency Coverage	0.15 – 300 MHz
Gain	37 dB nominal
Gain Variation	+/- 1 dB
Maximum Power Output	3 Watts (min)
Harmonic Distortion	-25 dBc @ 2.7 Watts Pout
Input / Output Impedance	50 Ω
Input VSWR	1.5 Maximum
Output VSWR	2.5 Maximum
Stability	Unconditionally stable into all passive loads
IOP ₃ Typical	44.5 dBm
Noise Figure	9 dB
Power Requirement	115/230 VAC +/-10% 50–60 Hz, 45 W. Max
Size and Weight	3.4 x 6.2 x 10.5 inches, 7 lbs
	8.8 x 15.7 x 26.6 cm, 3.2 Kg
Operating Temperature	0 ⁰ to 45 ⁰ C.
Protection	Units will withstand 20 dB overdrive
Output Connectors	BNC, Standard, SMA and N-type optional
Rack Mounting	Adaptors provided

Chapter 2 Operation

2.1 INTRODUCTION

The E&I 403LA RF amplifier is used to increase the RF output level of signal sources in the 0.15 to 300 MHz range. No tuning or any other form of adjustment is required.

The 403LA produces rated power output at its output connector, regardless of load impedance. Any power reflected due to output load mismatch is absorbed in the amplifier. Therefore, although the output impedance is 50 Ω (typical RF Output VSWR: 2:1), the amplifier will work into any load impedance.

The material contained in this document is the property of Electronics & Innovation Ltd., it is subject to change without notice.

2.2 Rack Installation

For standard 19" rack installations, rack mounting brackets are supplied with the unit. Remove the two M4 Phillips screws on each side of the cover nearest the front panel. Either bracket may be used on the right or left side. Attach the rack mounting brackets firmly using the hardware removed above. The rubber feet may be unscrewed and removed if the minimum vertical usage of the relay rack is necessary.

2.3 Mains Voltage

The supply voltage is automatically selected from 85 TO 264 VAC 47 – 63 Hz

2.4 Mains Fuse Rating

The mains fuse FI is located on the rear panel. The replacement part number details are:

1A Slow Blow E&I Part No: F975-ND. The 1A rating is correct for both 115 and 230 VAC

2.5 Mains Lead Connection

The unit comes supplied with a 6 foot mains cord.

2.6 Operation

Proceed as follows:

- Ensure input voltage is not excessive
- The IV RMS indicated maximum input voltage is 5 times the level of the input signal required to achieve maximum output. Input voltages in excess of 2V peak may permanently damage the instrument.
- Connect the input signal via a 50 Ω coaxial lead and BNC plug to the input connector.
- Connect the output via a 50 Ω coaxial lead and BNC plug to the load.

The material contained in this document is the property of Electronics & Innovation Ltd., it is subject to change without notice.

Chapter 3 Technical Information

3.1 Performance Checks

To determine the amplifier's performance carry out the following procedure.

3.1.1 Initial Check

The following check can be made whenever the condition of the unit is in question.

- (i) Connect power supply. Switch on power and observe that the switch illuminates.
- (ii) Connect the output of the 403LA amplifier to 20 dB attenuator.
- (iii) Connect a calorimetric power meter (HP434 or equivalent) to the output of the attenuator.
- (iv) Connect a sweep generator (Wavetek 2001 or similar) capable of sweeping the frequency range 1 to 300MHz to the input connector, *ensure that the output power of the generator is initially set to minimum.*
- (v) Adjust the output level of the sweep generator to -10dBm.
- (vi) Adjust the input CW signal to any frequency between 1 and 300MHz for 3W output.

If you can not attain RF power, verify that:

- (a) The mains fuse is correctly selected and not blown
- (b) The switch is illuminated.

If the mains fuse is not blown but you are still unable to get any RF power, either return the unit to E&I for repair or proceed to chapter 4.

3.2 Measurement of Gain

Equipment required:

- (a) Two power meters; HP 434 or equivalent
- (b) Sweep/Signal Generator
- (c) 20 dB Coupler

The material contained in this document is the property of Electronics & Innovation Ltd., it is subject to change without notice.

- (d) Attenuator, 20 dB

Connect the equipment as shown in Figure 2, then proceed as follows:

- (a) Increase power from the signal generator to attain an output power measurement of 3 watts as indicated on the output power meter.
- (b) Measure input power and calculate gain. Gain should be a nominal 37 dB
- (c) Vary the frequency of the sweep generator across the band from 150 KHz to 300 MHz. Note that the variation of gain is within +/- 1.5 dB

3.3 Measurement of Harmonics

Equipment required:

- (a) Sweep/Signal generator
- (b) Attenuator, 20 dB
- (c) Power Meter - HP434A
- (d) Spectrum Analyzer

Connect the equipment as shown in Figure 3 then proceed as follows:

- (d) Adjust the sweep/Signal generator at a CW center frequency of 150 MHz for an indicated output of 2.7W on the power meter.
- (e) Using the spectrum analyzer, check that the level of harmonics are less than -25 dB with respect to the carrier.
- (f) Vary the frequency of the generator from 150 KHz to 300 MHz, the harmonics should remain at -25dBc or below.

Chapter 4 Maintenance

4.1 Introduction

The E&I 403LA RF amplifier requires no periodic maintenance. The instrument is unconditionally stable and is fail safe under all load conditions. Damages can only be externally caused by an input signal in excess of the specified IV RMS maximum.

The material contained in this document is the property of Electronics & Innovation Ltd., it is subject to change without notice.

This chapter therefore, deals only with certain fundamental procedures for fault location and with the subsequent re-alignment procedures.

Performance limits quoted are for guidance only and should not be taken for guaranteed performance specifications unless they are also quoted in Figure 1.

4.2 Packing for Reshipment

In the event of the equipment being returned for servicing it should be packaged in the original shipping carton and packing material. If this is not available wrap the instrument in heavy paper or plastic and place in a rigid outer box of wood, fiberboard or very strong corrugated cardboard. Use ample soft packing to prevent movement. Provide additional support for projecting parts to relieve these of unnecessary shock. Close the carton securely and seal with durable tape. Mark the shipping container FRAGILE to ensure careful handling.

4.3 Access and Layout

NB: Removal of the cover voids the warranty!

The E&I Model 403LA amplifier is housed in an aluminum chassis. A block diagram schematic is illustrated in figure 4. The cover can be removed by releasing the 6 M3 screws on the side of the unit.

The rear panel supports the mains fuse holder, AC line cord and the cooling fan.

4.4 Power supply

The power supply does have a separate fuse. This fuse is rated at 2.5 amps / 250 Volts. It can be accessed without further disassembly. The power supply is mounted vertically on the left hand side of the amplifier. The fuse is located to the rear of the unit as indicated below.



The material contained in this document is the property of Electronics & Innovation Ltd., it is subject to change without notice.

4.5 The Amplifier Module

The power amplifier module is mounted on the RF heat sink. To remove this module, the RF heat sink must be demounted from the chassis. To demount the heat sink, unplug the wire from the power supply module. Remove the coaxial cables connecting the RF input and output to the front panel connectors. Remove the two M4 nuts holding the heat sink to the chassis base and the 2 M3 phillips screws holding the heatsink to the chassis side, then lift straight up.

Chapter 5 Safety:

Do not attempt to operate this unit with the cover removed. High AC and DC voltages are present. The cover prevents against electrical shock due to AC line voltages, high DC and RF fields. Further the cover provides part of the cooling system design. Components, specifically on the RF driver board are prone to over-heat and eventual failure if the unit is operated without the cover in place.

Ensure that the load is connected to the output prior to connecting the RF input to the unit. This will prevent high voltages being present and exposed at the output connector.

Only use the AC cord provided or equivalent.

Ensure that the mains outlet is properly grounded.

Figure 1

Gain Measurement

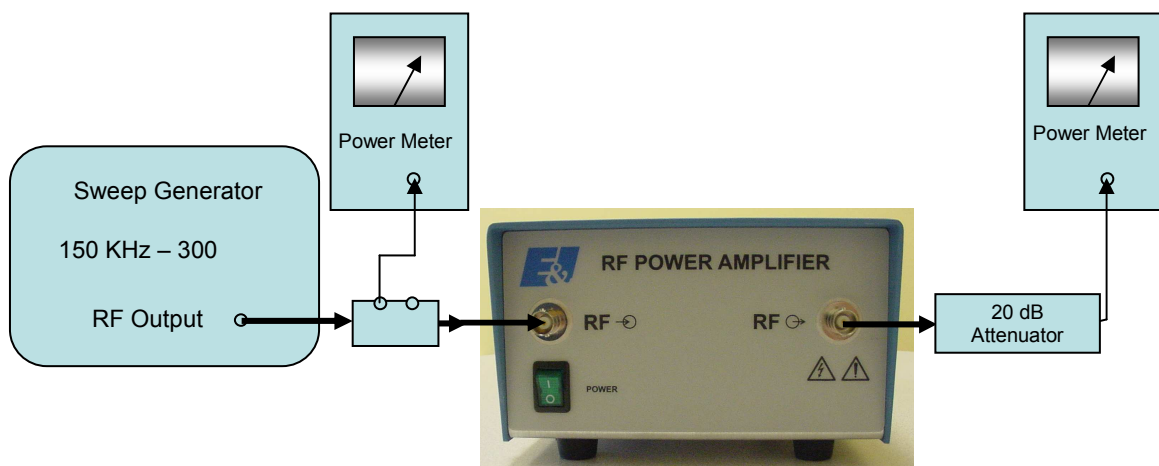

The material contained in this document is the property of Electronics & Innovation Ltd., it is subject to change without notice.

Figure 2

Harmonic Measurement

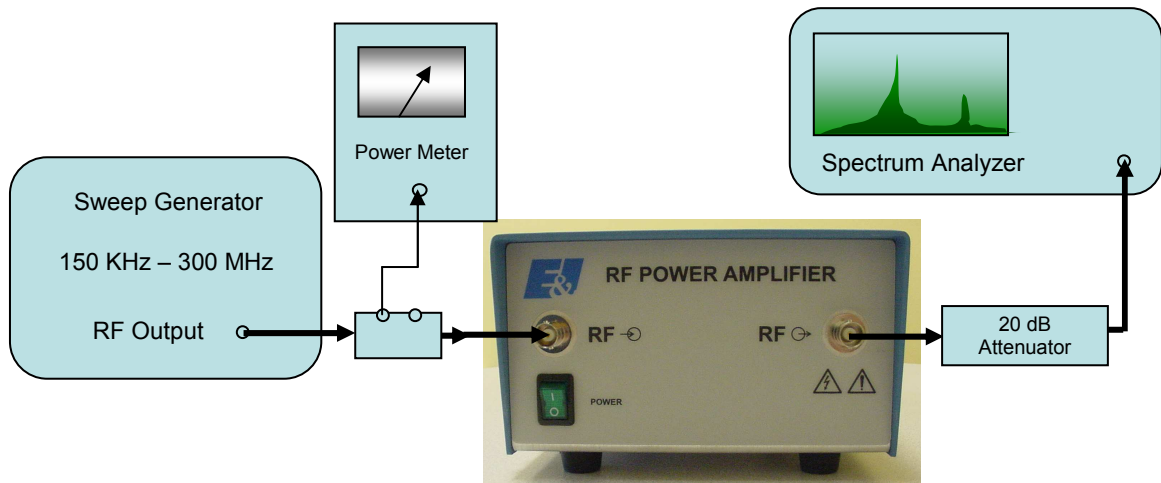
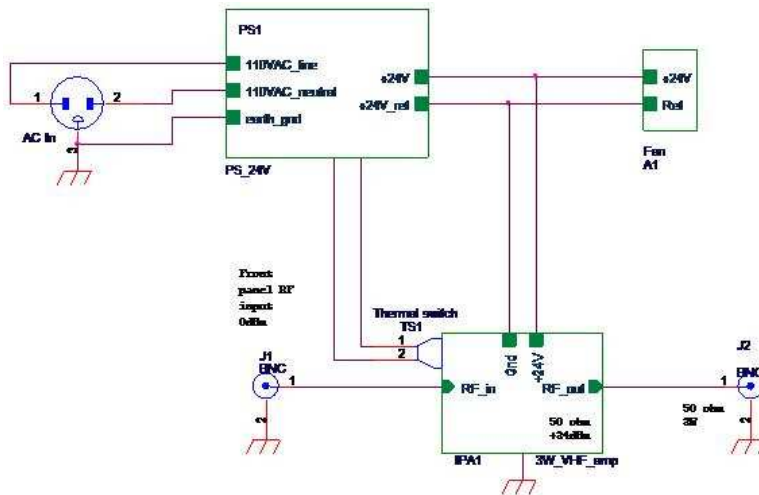

Figure 3

Block Diagram



Title		
403LA RF Amp		
Size	Document Number	Rev
A	403LA-SGH-D1	1
Date:	Friday, July 02, 2004	Sheet 1 of 1

The material contained in this document is the property of Electronics & Innovation Ltd., it is subject to change without notice.