



ABN 43 064 478 842

231 Osborne Avenue Clayton South, VIC 3169
PO Box 1548, Clayton South, VIC 3169
t 03 9265 7400 f 03 9558 0875
freecall 1800 680 680
www.tmgtestequipment.com.au

Test & Measurement

- > sales
- > rentals
- > calibration
- > repair
- > disposal

Complimentary Reference Material

This PDF has been made available as a complimentary service for you to assist in evaluating this model for your testing requirements.

TMG offers a wide range of test equipment solutions, from renting short to long term, buying refurbished and purchasing new. Financing options, such as Financial Rental, and Leasing are also available on application.

TMG will assist if you are unsure whether this model will suit your requirements.

Call TMG if you need to organise repair and/or calibrate your unit.

If you click on the "Click-to-Call" logo below, you can call us for FREE!

TMG Corporate Website

TMG Products Website



Click-to-Call
TMG Now



Product Lifecycle Management System

Disclaimer:

All trademarks appearing within this PDF are trademarks of their respective owners.





Version
04.00

February
2008

R&S®ZVA Vector Network Analyzer

High-end network analyzer up to 8 GHz, 24 GHz, 40 GHz or 50 GHz with two or four test ports

- ◆ Linear and nonlinear amplifier and mixer measurements
- ◆ High-performance pulse profile measurements with 12.5 ns resolution
- ◆ True differential measurements for reliable characterization of active devices with balanced ports
- ◆ High output power typ. >15 dBm
- ◆ Wide dynamic range typ. >140 dB
- ◆ High measurement speed <3.5 μ s per test point
- ◆ Wide IF bandwidth: 1 MHz/5 MHz
- ◆ Versatile calibration techniques TOSM, TRL/LRL, TOM, TRM, TNA, UOSM
- ◆ Automatic calibration units
- ◆ Various functions for performance optimization

Versatile – powerful – future-proof – user-friendly

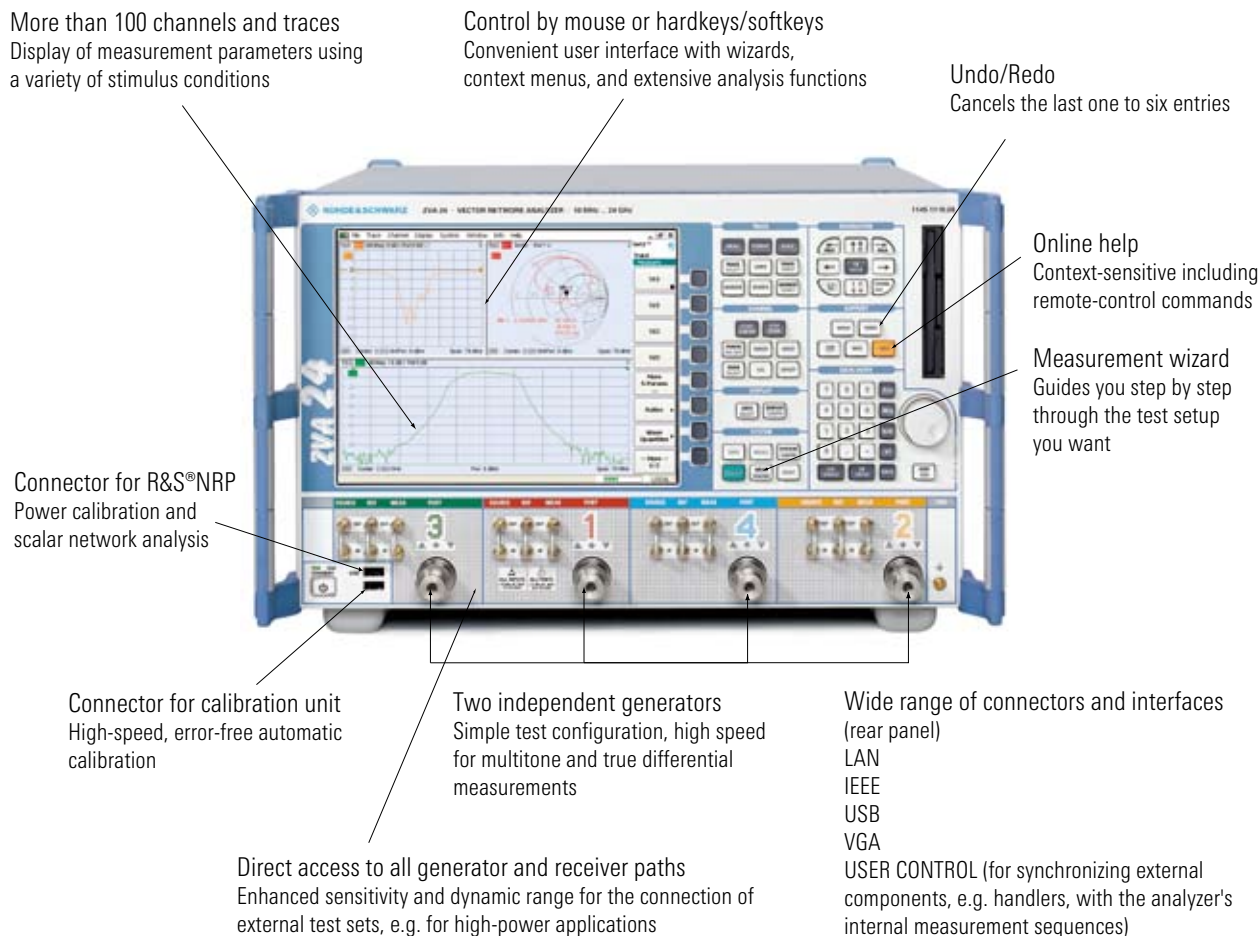

Condensed data

Number of test ports	2 or 4
Frequency range	300 kHz to 8 GHz (R&S®ZVA8) 10 MHz to 24 GHz (R&S®ZVA24) 10 MHz to 40 GHz (R&S®ZVA40) 10 MHz to 50 GHz (R&S®ZVA50)
Measurement time per test point	<3.5 µs
Measurement time (201 test points)	4.5 ms
Data transfer time (201 test points)	
Via IEC/IEEE bus	<2.9 ms
Via VX11 over 100 Mbit/s LAN	<1.3 ms
Via RSIB over 100 Mbit/s LAN	<0.7 ms
Switching time	
Between channels	<1 ms
Between instrument setups	<10 ms

Dynamic range at 10 Hz measurement bandwidth	
Between test ports	typ. >140 dB
With direct receiver access	typ. >145 dB
Output power at test port	>13 dBm, typ. 15 dBm
Power sweep range	>50 dB, typ. 60 dB
IF bandwidths	1 Hz to 1 MHz (5 MHz optional)
Number of channels, diagrams, traces	>100 each ¹⁾
Number of test points per trace	1 to 60001
Operating system	Windows XP Embedded

¹⁾ Limited by available RAM capacity.

Technological progress in RF and microwave engineering means that network analyzers in development and production continuously have to meet new demands for ease of operation, flexibility, and performance.

With its new R&S®ZVA family of vector network analyzers, Rohde & Schwarz is taking a future-oriented approach. The analyzers offer a perfect balance between measurement speed, dynamic range, flexibility, and precision, making them ideal for present and future measurement tasks.

Rohde & Schwarz previously set standards in RF and microwave measurements with its R&S®ZVR family of network analyzers, and now continues this success with the R&S®ZVA. The fundamental mixing concept employed by the analyzer's receivers ensures high sensitivity and a wide dynamic range. Extremely fast synthesizers make for short measurement times.

Its excellent characteristics, new functionality, sophisticated GUI, and extremely high flexibility make the R&S®ZVA an

indispensable tool for demanding measurement tasks in labs and production.

Test set design for enhanced performance and flexibility

The test set includes a number of special design features. There is one measurement channel and one reference channel for each test port, an RF switch in each generator path, and one generator for each pair of test ports. This makes the R&S®ZVA an analyzer of unprecedented performance and functionality, which is especially true for the four-port model:

- ◆ True differential measurements on balanced DUTs
- ◆ Parallel signal output, e.g. of LO and RF signals for mixer or intermodulation measurements
- ◆ Parallel signal output and measurement at the test ports for measuring two or more DUTs simultaneously
- ◆ Connection of external test setups, e.g. power amplifiers, or use as a multichannel receiver, e.g. for antenna measurements, by means of the direct generator/receiver access option (see page 14)

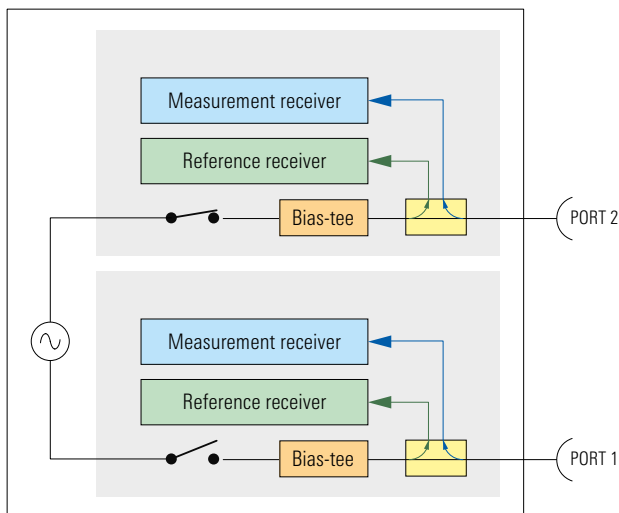

Block diagram of the R&S®ZVA two-port model

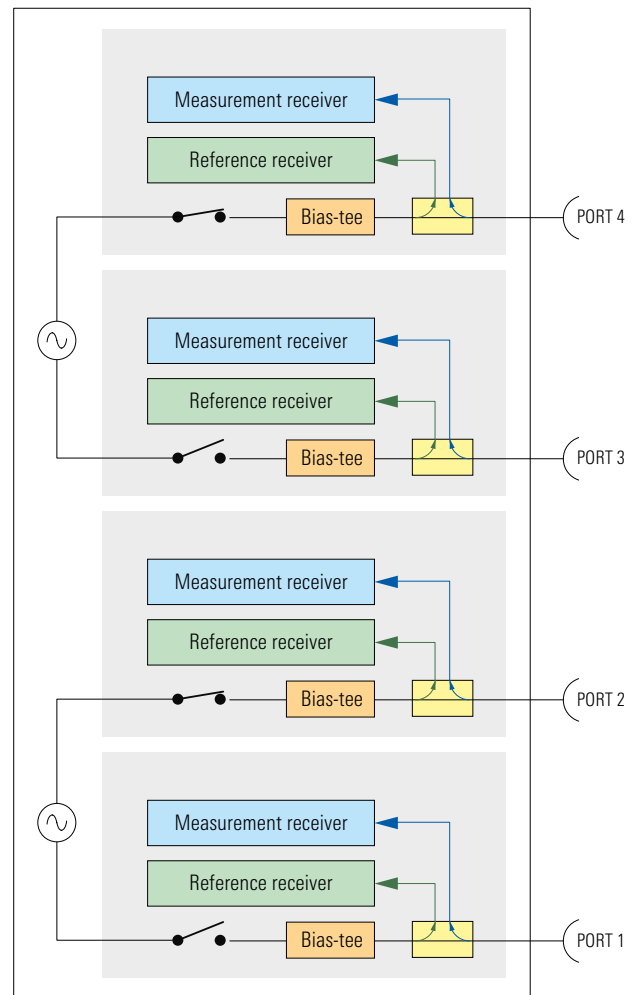

Block diagram of the R&S®ZVA four-port model

High measurement throughput

Wide dynamic range for fast and accurate measurements

The R&S®ZVA sets new standards in measurement speed. Its large IF bandwidths and fast synthesizers combine to yield short measurement times and thus high throughput in manual adjustments and automated production sequences. The measurement time per test point is less than 3.5 μ s in the CW mode; a frequency sweep over 200 test points takes less than 5 ms.

Due to the analyzer's wide dynamic range and low phase noise, this speed advantage does not compromise measurement accuracy.

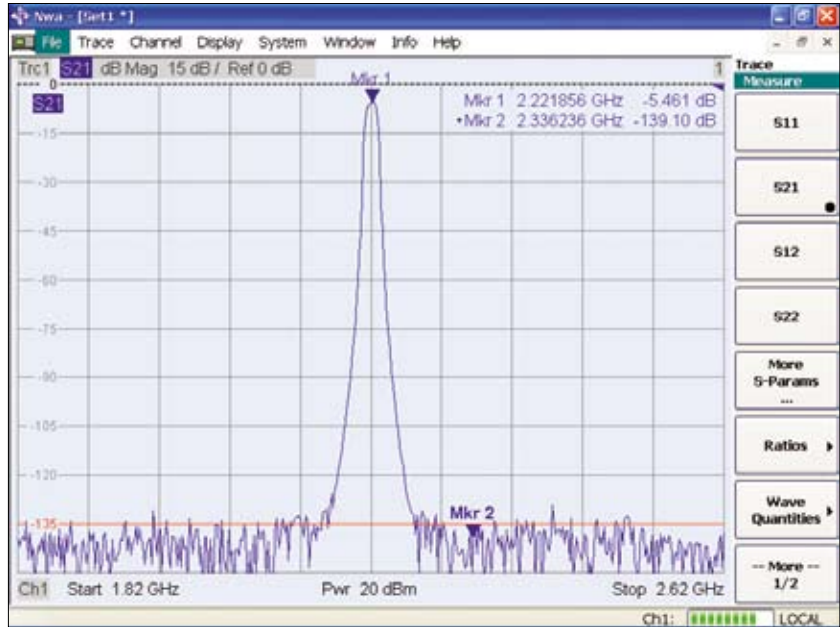

Dynamic range between test ports at 10 Hz IF bandwidth

Fast switching between instrument setups

When analyzing two or more DUTs, you no longer have to load the required instrument setups from the hard disk one after the other. Once called, setups remain available in RAM, including calculated data, e.g. calibration values obtained by interpolation. You can therefore switch between setups virtually without delay, i.e. in less than 10 ms by remote control. With conventional instruments, recalling setups can take up to one second. Each setup is represented by a separate measurement window.

This design feature also makes it easier to handle large volumes of measured data. If a display area becomes too "crowded", data can easily be distributed to other windows (setups). You can switch between windows by using the mouse or pressing a key.

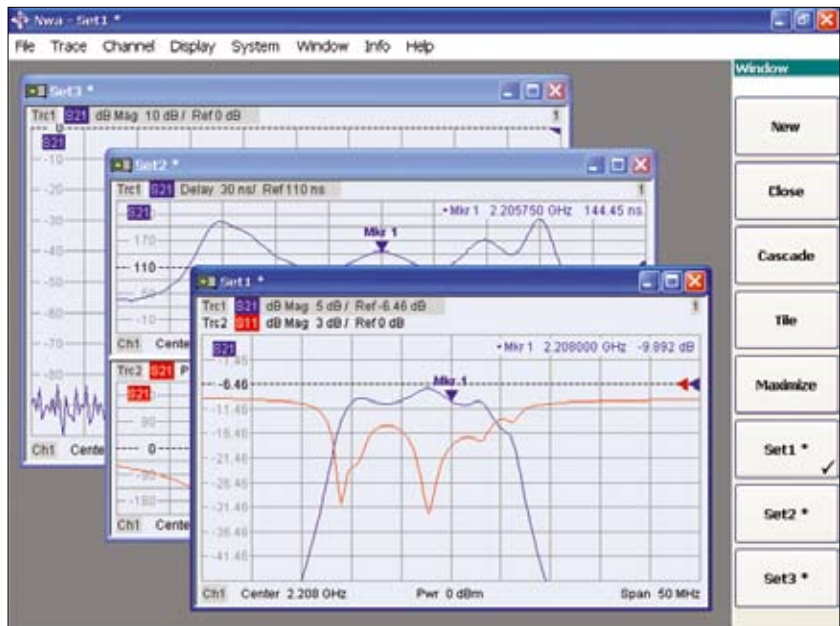

Switching between setups at the click of a mouse

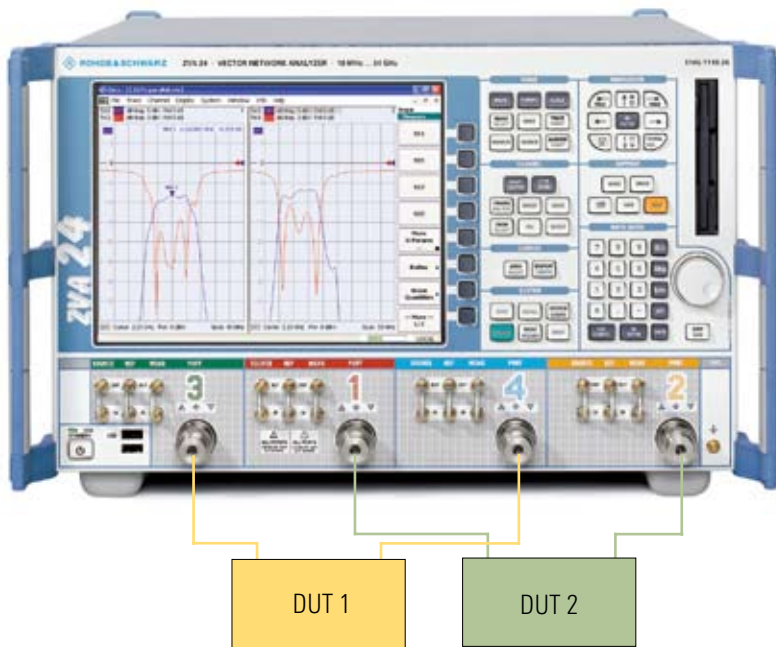

Parallel measurements:
The test signals are applied to the DUTs simultaneously, and measurements are also carried out simultaneously. Compared to the standard (sequential) mode, measurement throughput is doubled with the test configuration shown here

Segmented sweep for optimized speed, accuracy and dynamic range

The segmented sweep function allows you to divide a sweep into a virtually unlimited number of segments. Sweep parameters such as test point spacing, measurement bandwidth, and generator power can be defined separately for each segment and thus accurately matched to the DUT characteristic. Measurement speed and accuracy can thus be further optimized.

Parallel measurements – up to four times faster

In addition to the standard operating mode, the concept of the R&S® ZVA allows test ports to be organized in groups, e.g. in groups of two ports

each, or in four groups of one port each. Measurements are carried out on the various groups simultaneously, provided the test parameters are identical for each group. This means that measuring two or more DUTs in the parallel mode takes no more time than measuring a single DUT in the standard mode. Compared to sequential measurements, measurement speed will thus double when measuring two two-port DUTs in parallel and quadruple when measuring four one-port DUTs in parallel.

Data transfer simultaneous with sweep

Since trace data is transferred via the IEC/IEEE bus or LAN at the same time measured data is being captured, data transfer time on the R&S® ZVA is insignificant.

Channel bits and user port – high-speed control of external devices

To speed up automatic test cycles even further, a special port for trigger I/O signals and status indication is provided on the rear panel. These signals directly synchronize external devices of a test setup or the settings of a DUT with the internal measurement sequences of the R&S® ZVA. No remote control sequences are required, thus saving execution time. The pins of the USER CONTROL port also provide information on the net time required for measuring one point, one sweep, or carrying out a partial measurement. This makes it easy to determine net measurement times and optimize synchronization.

Display and analysis functions – user-friendly and flexible

State-of-the-art DUTs feature a steadily increasing number of complex functions and ports, which also places higher demands on the instrument's display capabilities. The R&S®ZVA provides highly versatile functions for displaying results in a straightforward manner.

Virtually unlimited number of channels and traces

Over 100 traces can be combined in any manner within the individual diagrams and assigned to over 100 different channels¹⁾. DUTs can thus be measured using a wide variety of stimulus conditions, and all parameters of interest can be displayed on the screen. The names of traces, channels, and markers can be edited and replaced by user-specific names to make them easier to identify.

Easy export and import of results

The use of the Windows XP Embedded operating system, in conjunction with a variety of interfaces, makes it easy to integrate measurement results into documentation by saving screen contents as *.bmp, *.png, *.jpg, or *.emf files, and exporting these files into a text processing system. Trace data can be stored as *.snp, *.csv, or *.dat files and subsequently analyzed and processed using other tools. In addition, *.snp and *.csv files created by means of external tools, for example, can be imported into the R&S®ZVA as stored trace data.



Flexible channel and trace layout

Convenient equation editor for complex trace mathematics

The R&S®ZVA includes a universal equation editor for trace mathematics including even extensive functions. Using these functions, you can link any active traces and stored traces in a variety of ways in realtime. This makes external analysis programs unnecessary. You can store the equations you have generated, process them by means of external tools, and reload them as required.

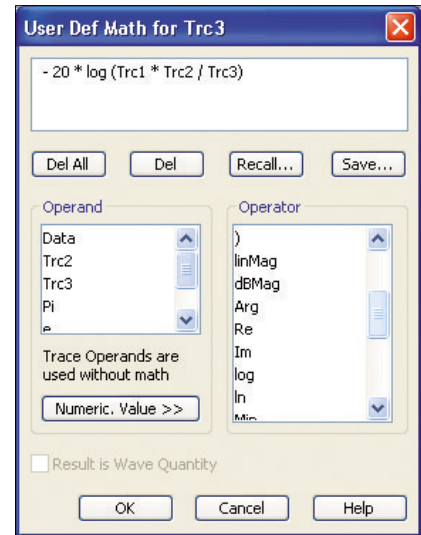

Equation editor

¹⁾ A channel designates an independent set of test parameters including, for example, the sweep mode, test point spacing, power, measurement bandwidth, and calibration technique. The number of channels is limited only by the instrument's RAM capacity.

Calibration

Versatile calibration techniques for all fields of application

The R&S®ZVA not only offers classic TOSM calibration (**T**hrough, **O**pen, **S**hort, **M**atch), but also a variety of other calibration techniques. Since each test port of the R&S®ZVA is equipped with a reference receiver of its own, modern 7-term calibration techniques can be used. These include TRL/LRL (**T**hrough, **R**eflect, **L**ine/**L**ine, **R**eflect, **L**ine), TOM (**T**hrough, **O**pen, **M**atch), TNA (**T**hrough, **N**etwork, **A**ttenuator), and TRM (**T**hrough, **R**eflect, **M**atch), which are suitable for calibration in test fixtures or on wafers. Since calibration is performed directly on the DUT plane, any effects from the test fixture are eliminated.

Automatic calibration – fast, error-free, and with high precision

While all manual calibration techniques such as TOSM, TRM, and TRL can be used for multipoint measurements, they are time-consuming, error-prone, and lead to excessive wear of the calibration standard. Rohde & Schwarz offers an automatic calibration unit for coaxial one-port and multipoint calibration. The unit is ready to operate immediately after being connected and performs complete four-port calibration covering 201 test points in less than 30 seconds.



Calibration unit

The R&S®ZVA allows for any combination between the analyzer's test port connectors and the connectors of the calibration unit. The analyzer detects the connections automatically. Errors due to wrong connections are a thing of the past.

The R&S®ZVA's firmware now also allows the recharacterization of calibration units by the user. Moreover, it is possible to characterize a calibration unit together with an adapter of any type. By treating the adapter as part of the calibration unit, the R&S®ZVA supports any combination of any connector types, which means that the calibration unit itself can be equipped with up to four different

connectors. User-specific adapters can also be placed on the connectors of the calibration unit, thus protecting the connectors against wear.

Adapter removal functionality

The UOSM (**U**nknown Through, **O**pen, **S**hort, **M**atch) calibration technique allows a through-connection with unknown parameters to be used as a calibration standard. This makes it possible to use any adapter with any types of connectors as a "U" (adapter removal functionality), thus supporting calibration of a DUT with different connector types.

Measurements on multiports and balanced components

Standard measurement mode: virtual differential mode

The R&S®ZVA characterizes balanced DUTs with one or two balanced ports quickly and accurately. The balanced DUT is directly connected to the analyzer test ports. Its unbalanced S-parameters are measured, and the mixed-mode S-parameters are calculated from these values.

The numerous traces and diagrams offered by the R&S®ZVA provide full characterization of the DUT and straightforward display of all measurement quantities. No sophisticated settings are required on the part of the user. Convenient marker search and analysis functions facilitate result evaluation especially in the case of filter measurements, for example by determining the filter parameters such as bandwidth, ripple, quality factor, etc.

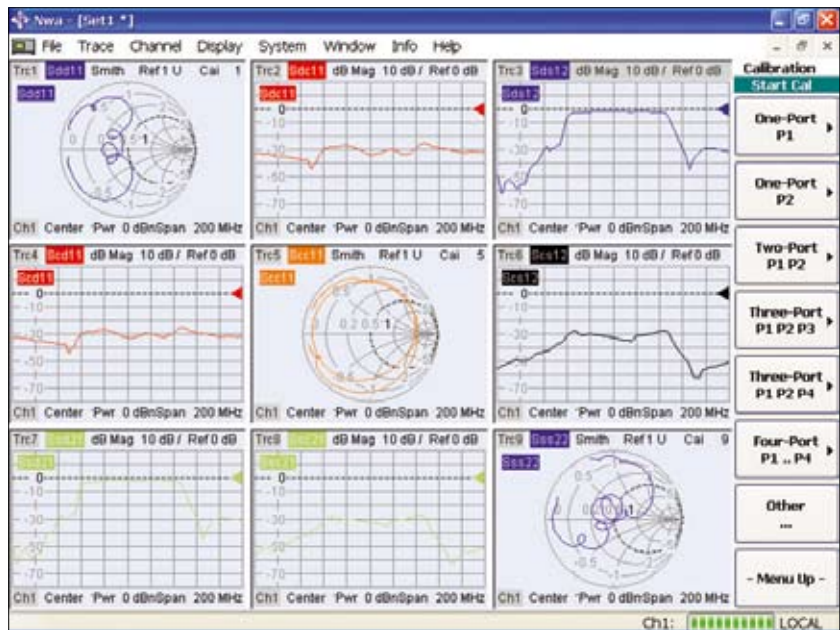

Display of mixed-mode S-parameters of a SAW filter; a configuration wizard configures all 9 or 16 S-parameters at a few keystrokes

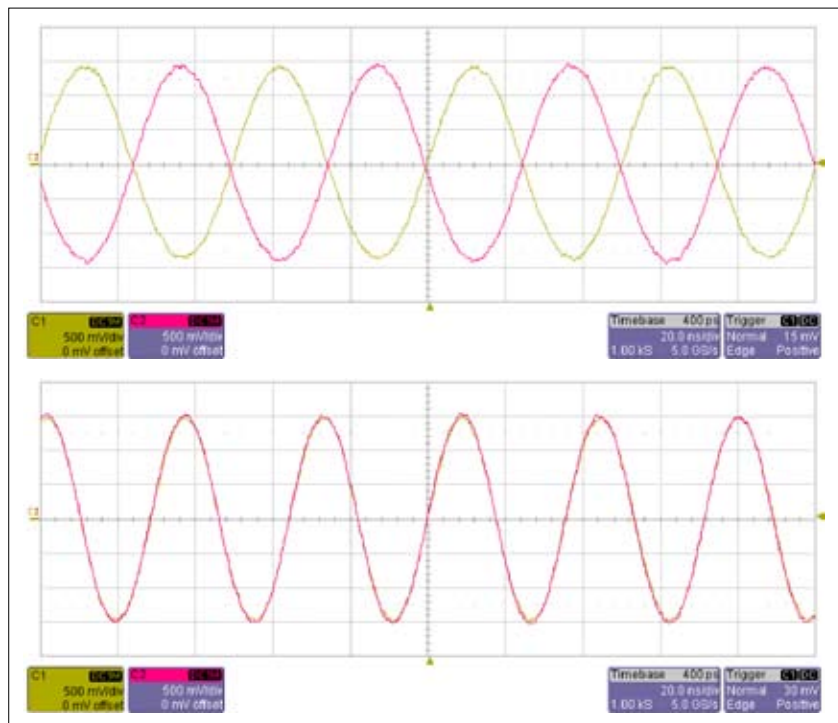

Output signals of two R&S®ZVA ports in true differential mode (measured with an oscilloscope) using stimulus signals with 0° or 180° phase difference

True differential measurement mode

Active components in particular may show a distinctly different response to a stimulus signal, depending on whether the virtual (standard) or the true differential measurement mode is applied.

To obtain reliable results even for active differential DUTs, the R&S®ZVA-K6 option provides true differential stimulation and measurements. The test signals delivered by the two internal generators are applied at the reference plane simultaneously with 180° or 0° phase difference. The measurements on the selected test ports are performed simultaneously. The R&S®ZVA-K6 option also supports true phase imbalance and true amplitude imbalance sweeps of the two stimulus signals.

As with standard measurements, calibration is performed either manually using a calibration kit, or automatically with a calibration unit.

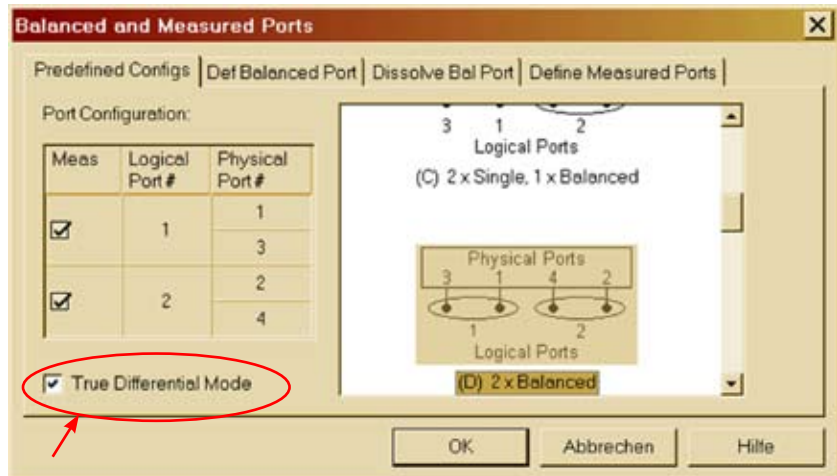

Dialog for configuring a balanced measurement: the true differential mode is selected at a single mouse click

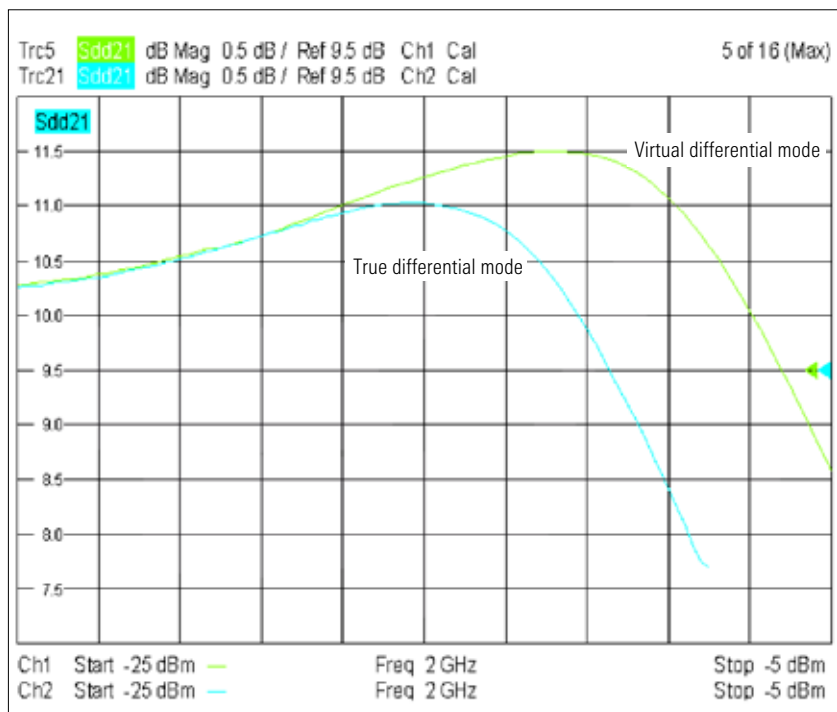

Compression measurement of an amplifier – traces obtained for S21 in virtual and true differential mode

Measurements on multiports and balanced components

Measurement wizard – step by step to the test setup you want

Measuring multiports and balanced DUTs by means of a network analyzer usually requires major configuration effort on the part of the user, for example for configuring the port topology, selecting the parameters to be displayed, setting the sweep mode, or choosing the appropriate calibration technique. With the R&S® ZVA, a measurement wizard guides you step by step through the test setup to create the configuration you want, queries all necessary inputs and offers default settings for the measurement task at hand. Using the wizard, you can completely configure the R&S® ZVA to display all 16 mixed-mode S-parameters of a balanced two-port in virtually no time.

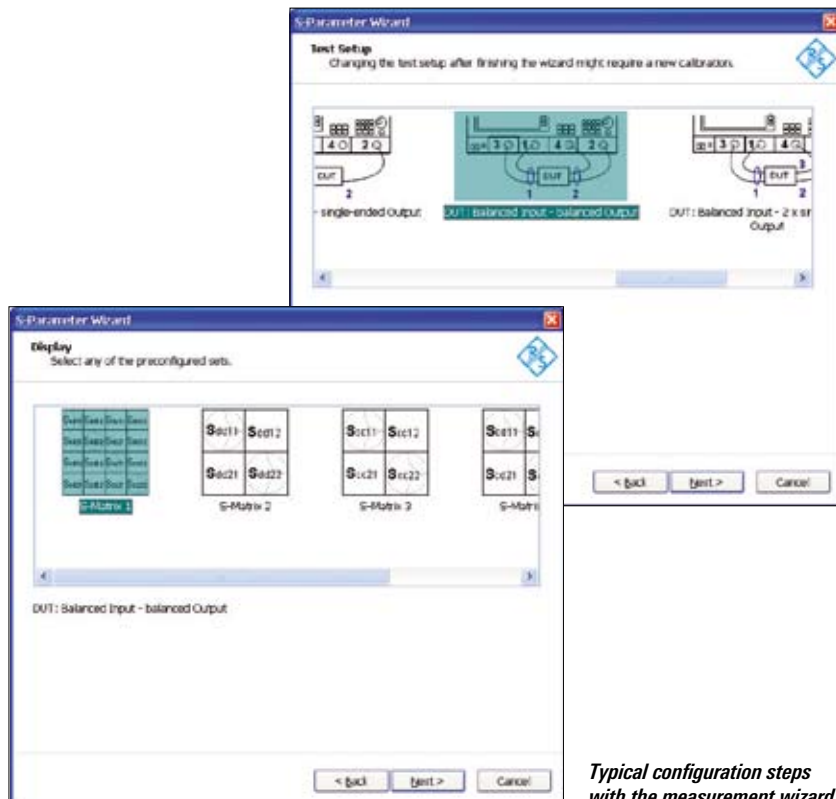

Typical configuration steps with the measurement wizard

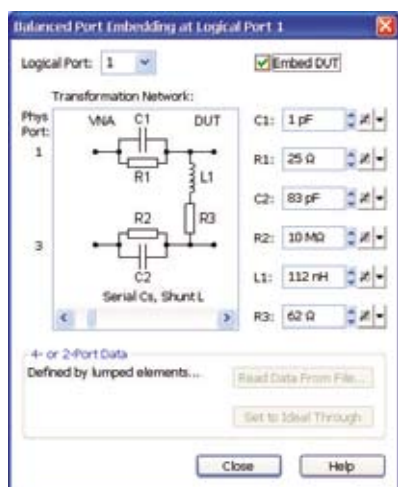

Parameterizable network for virtual impedance matching

Embedding/deembedding – impedance matching using virtual networks

Coaxial and balanced components such as SAW filters, which are used in front-ends of mobile phones, for example, must be specified together with the networks that match them to the impedance of the surrounding circuit. In addition, parasitic effects, which occur when the DUT is installed in its operational environment, can be simulated. Using special algorithms, the R&S® ZVA embeds the DUT in virtual matching networks, and also deembeds it to eliminate parasitic effects such as caused by strip lines.

The R&S® ZVA offers various types of transformation networks. The values of the network elements can be edited. If you modify values of individual elements, the R&S® ZVA immediately recalculates the network and (de)embeds the DUT in the new network in quasi-realtime.

Alternatively, you can read *.s2p and *.s4p files generated with CAE tools into the R&S® ZVA and use the data for embedding/deembedding.

Amplifier and mixer measurements

The R&S®ZVA system concept, featuring independent synthesizers, enables measurements on amplifiers and frequency-converting DUTs such as mixers and frontends. The measurements stand out for their high versatility, wide dynamic range, high speed, and accuracy.

Internal as well as several external generators can be configured, calibrated, and controlled independently of one another. The high spectral purity of the source signals as well as the high intercept point and high sensitivity of the receivers eliminate the need for external filters in multitone measurements and measurements on frequency-converting DUTs.

Large- and small-signal behavior in a single sweep

The R&S®ZVA's high output power and wide power sweep range of more than 50 dB (typ. 60 dB) allow the transmission and compression characteristics of amplifiers and mixers to be determined largely without any additional preamplifiers being required. This measurement is carried out simply and quickly versus frequency and power. The power sweep range is traversed wear-free and without interruption, since no mechanical attenuators have to be switched. Small- and large-signal behavior can thus be displayed in a single sweep.

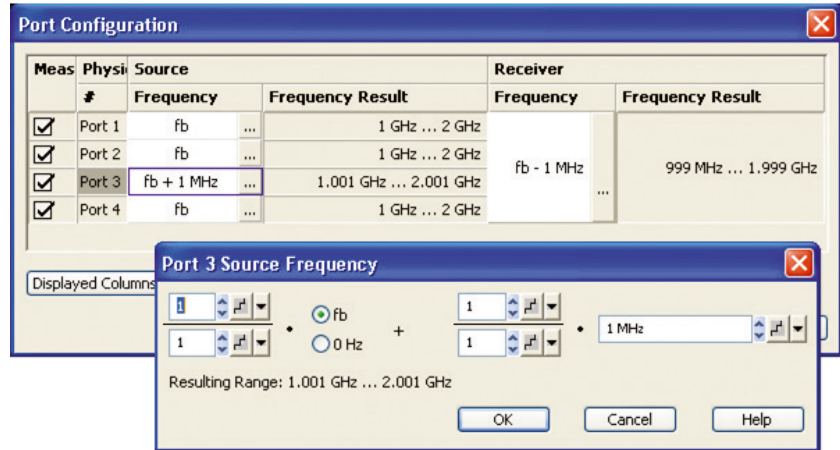

Dialog for configuring multitone measurements

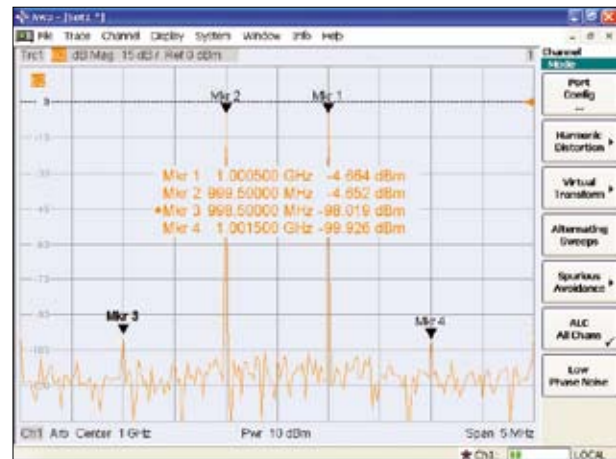

Intermodulation products of a frontend

Second internal source for quick and easy intermodulation and mixer measurements

The R&S®ZVA four-port model provides a second independent source; therefore, intermodulation measurements on amplifiers and conversion gain measurements on mixers can be performed without an external generator. The R&S®ZVA receivers feature very good power-handling capability and low phase noise, which enables high-quality intermodulation measurements requiring only a minimum of external components.

Amplifier and mixer measurements

Hot S-parameter measurements – optimization of amplifiers under load conditions

Power amplifiers must be characterized under full load condition to ensure that they are optimally matched to the load connected to their output. To determine S_{22} under realistic operating conditions, a stimulating signal is applied to the amplifier input. A low-power signal – which is the actual S_{22} test signal – is applied to the amplifier output (i.e. in the reverse direction). To separate the high-power output signal of the amplifier from the reflected low-power signal, the two sources are swept in parallel, but with a small frequency offset. Thus, only the desired S_{22} measurement signal passes the IF filter. The R&S® ZVA performs this measurement with a wide dynamic range due to the robust automatic level control and the high selectivity and sensitivity of its receivers.

Conversion gain and intermodulation measurements on mixers at high speed and with wide dynamic range

The four-port R&S® ZVA requires only one additional external source to perform intermodulation measurements on mixers. The external source is controlled via the analyzer's LAN or IEC/IEEE bus interface. Using the frequency conversion option (R&S® ZVA-K4), you can display a mixer's matching, conversion gain, isolation, group delay, and intermodulation products versus frequency and power.

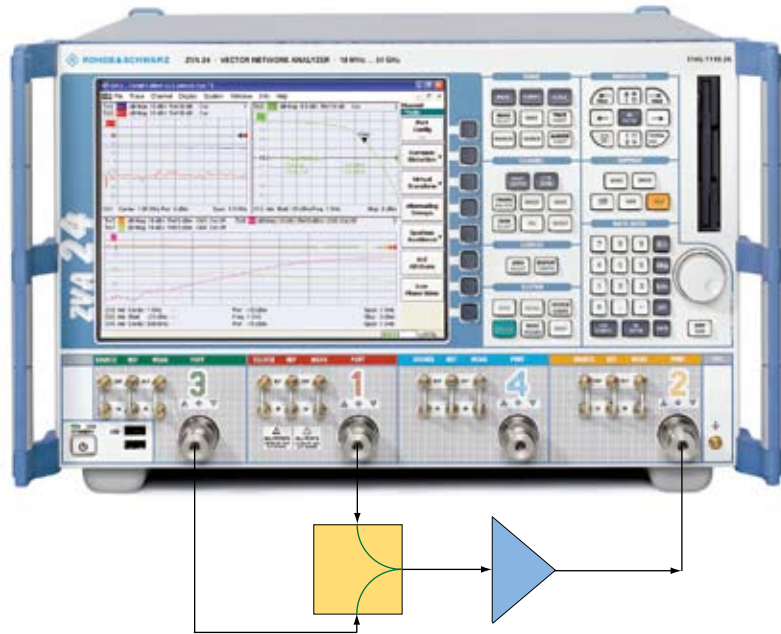

Test setup for an amplifier measurement – intermodulation products, S-parameters, compression, and harmonics

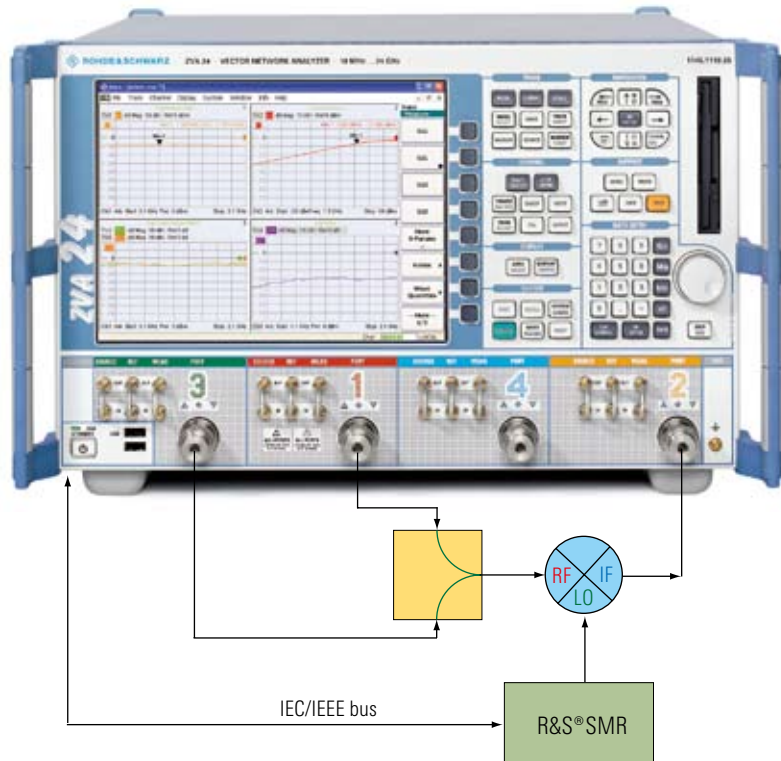

Test setup for a mixer measurement – conversion loss, isolation, matching, and intermodulation products

Power measurements and scalar network analysis by means of the R&S®NRP

One or more power meters of the R&S®NRP series can be directly connected to the R&S®ZVA via the USB interface or by using an active USB hub. The power meters are treated by the R&S®ZVA like additional test ports. The R&S®ZVA processes the measured values and displays them as traces versus frequency or power. Besides adding power measurement inputs to the R&S®ZVA, this functionality allows measurements on frequency-converting DUTs to be performed without access to, or knowledge of, the DUT's internal LO, in the same way as with a scalar network analyzer.

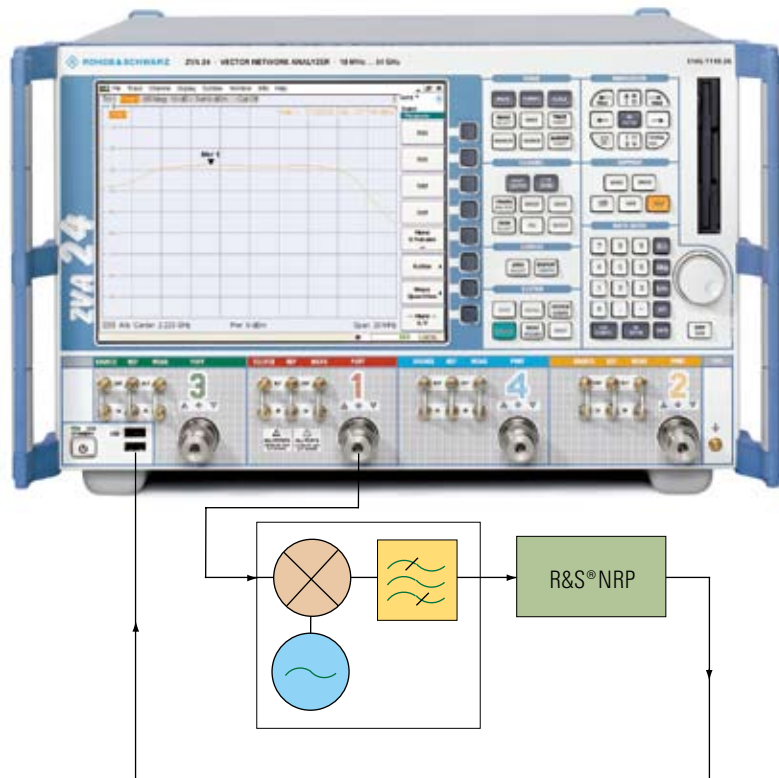

Test setup for a scalar mixer measurement

Features for amplifier measurements	Features for mixer measurements
<ul style="list-style-type: none"> ◆ Bias-tees at all test ports ◆ High output power at all test ports ◆ Wide power sweep range ◆ High 0.1 dB compression point ◆ RMS and peak detector ◆ Determination of n-dB compression point ◆ Second independent source (four-port model) for intermodulation measurements ◆ Power added efficiency (PAE) measurement ◆ Measurement of efficiency and stability factors ◆ DC inputs for measuring supply currents and power detector characteristics ◆ Intermodulation measurement versus frequency and power (R&S®ZVA-K4) ◆ Hot S-parameter measurements (R&S®ZVA-K4) ◆ Generator and receiver step attenuators for expanding the usable power range (R&S®ZVA-B2x/-B3x) ◆ Power measurement with the R&S®NRP power meter ◆ Measurements on pulsed signals (average pulse, point-in-pulse, pulse profile, R&S®ZVA-K7/-B7) 	<ul style="list-style-type: none"> ◆ Conversion loss/gain, compression, intermodulation, isolation, and matching measurements versus frequency and power (R&S®ZVA-K4) ◆ Relative phase and group delay measurements ◆ Second internal source available as LO for conversion gain measurements ◆ Control of external generators from Rohde & Schwarz and other manufacturers ◆ Editable ASCII driver file for creating customized drivers for SCPI-compatible instruments ◆ Scalar network analysis by means of the R&S®NRP power meter

Options for enhanced flexibility, power, and dynamic range

Direct generator and receiver access for all ports

With the direct generator/receiver access options, the signal paths of the receivers and generators are taken directly to the front panel. You have direct access to the generators and receivers of all reflectometers, since the internal couplers are bypassed. With a fully configured R&S®ZVA, i.e. with four ports, all eight receivers can capture and process measurement data in parallel.

Generator and receiver step attenuators are optionally available for each port to expand the usable generator and receiver power ranges for compression and intermodulation measurements. The output power range at the test port can be decreased down to <-100 dBm; the compression-free input power range of the receiver will increase to $+27$ dBm.

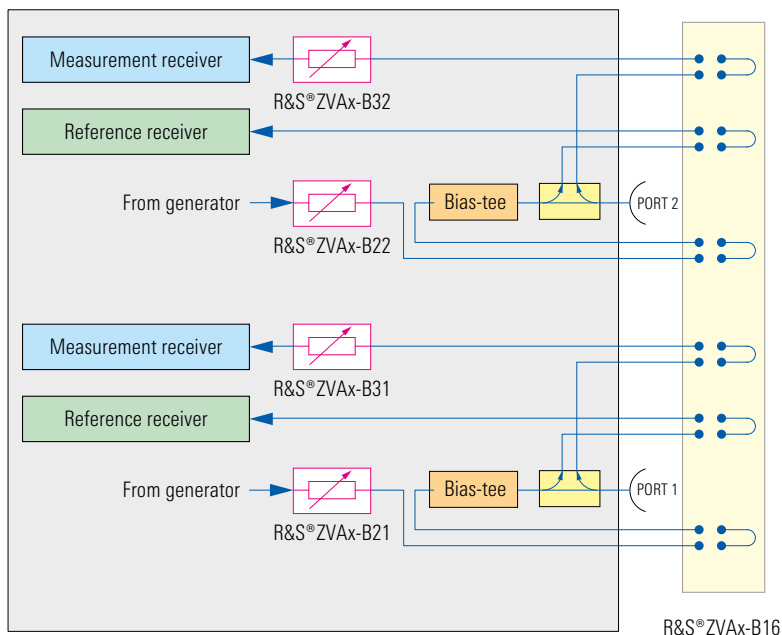

Direct generator and receiver access options (blue); generator and receiver step attenuator options (red)

Up to 150 dB dynamic range with direct receiver access

Since the couplers are bypassed and therefore introduce no attenuation, sensitivity is increased by up to 10 dB in the direct mode. This means that high-blocking DUTs can be measured with a dynamic range of up to 150 dB at 1 Hz IF bandwidth.

By connecting suitable external directional couplers, one- and two-port calibration techniques can be used to enhance measurement accuracy without any significant loss in dynamic range.

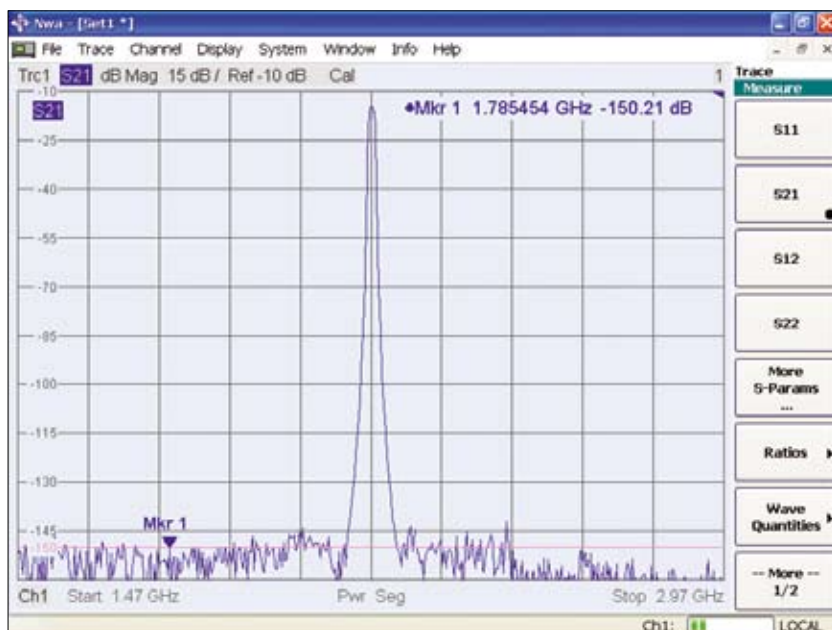

Typical dynamic range with direct receiver access

Output power boosted to +30 dBm for amplifier measurements

Direct access to all generator and receiver paths allows the flexible configuration of complex external test sets. Such test sets may include filters for improved harmonic suppression or amplifiers for boosting the output power. The output power can be increased to +30 dBm by looping a preamplifier into the generator path and inserting suitable attenuators in the measurement and reference paths.

Connecting external components (e.g. amplifiers) ahead of the reference path eliminates drift and temperature response in S-parameter measurements. Moreover, all calibration techniques are available, and the user fully benefits from the advantages of high measurement accuracy and long-term stability.

High-speed time domain analysis with enhanced resolution capability

Using the time domain option, you can, for example, locate discontinuities in test fixtures and cables and analyze them, e.g. by means of a gated S-parameter measurement. You can display impedance versus length, which is of interest in cable measurements. Due to the R&S®ZVA's high computing power, the time domain option barely slows down sweep speed. Thus, this option allows cavity resonator filters to be adjusted quickly and easily.

The time domain option can be used in conjunction with various window functions such as Hamming, Hann, Bohman, or Dolph-Chebyshev.

The R&S®ZVA with an external test set including an amplifier and a harmonics filter

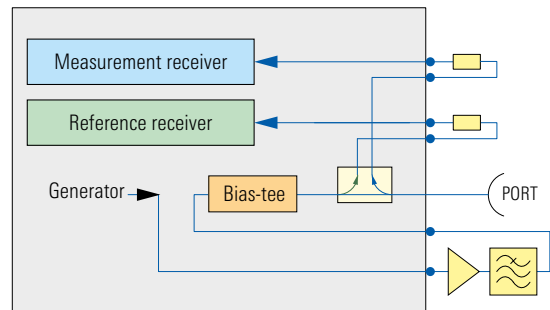

Dialog for configuration of a time domain measurement

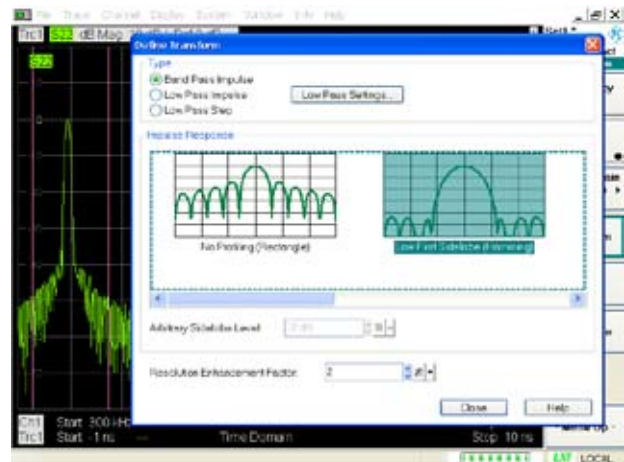

5 MHz receiver bandwidth

The R&S®ZVA has a maximum IF bandwidth of 1 MHz as standard. To reduce measurement times even further, the R&S®ZVA-K17 software option offers IF bandwidths up to 5 MHz. This reduces the net sampling time per point to approx. 430 ns. The option not only speeds up measurements in the frequency domain. It also provides improved performance for point-in-pulse and pulse profile measurements on pulses of a few microseconds length by means of easy-to-configure standard CW or time sweeps, where the S-parameters or amplitudes of pulses are measured as a function of time.

Pulsed measurements – pulse profile measurements

The R&S®ZVA performs typical pulsed-signal measurements such as point-in-pulse or high-PRF-mode measurements by means of the direct generator/receiver access and frequency conversion options. The R&S®ZVA-K7, R&S®ZVA-B7 pulsed measurements option provides a convenient, high-performance solution especially for pulse profile measurements¹⁾: Even the profiles of very short pulses with a duration far below 100 ns are represented with a resolution of 12.5 ns in the time domain. Traces are updated at a high rate, which greatly facilitates adjustment procedures.

The R&S®ZVA displays amplitude characteristics (the powers measured in the measurement and the reference channels, and their ratios), as well as S-parameters in magnitude and phase. Single pulses, double pulses, or pulse sequences up to 3 ms length (R&S®ZVA-K7), or 25 ms length (R&S®ZVB-B7) can easily be measured. The option includes methods for compensating the group delay of the DUT, which makes it possible to measure pulses whose length is shorter than the group delay of the DUT. IF bandwidths up to 10 MHz are available for short pulse edges²⁾.

Principle of pulse profile measurements

The A/D converter outputs uncorrected sampling values, which are first stored in a high-speed buffer (RAM), and then digitally processed block by block up to the display (see blue arrows in block diagram). Therefore, with sampling performed independently of signal processing, the pulse signal can be sampled at the converter's maximum rate of 80 MHz.

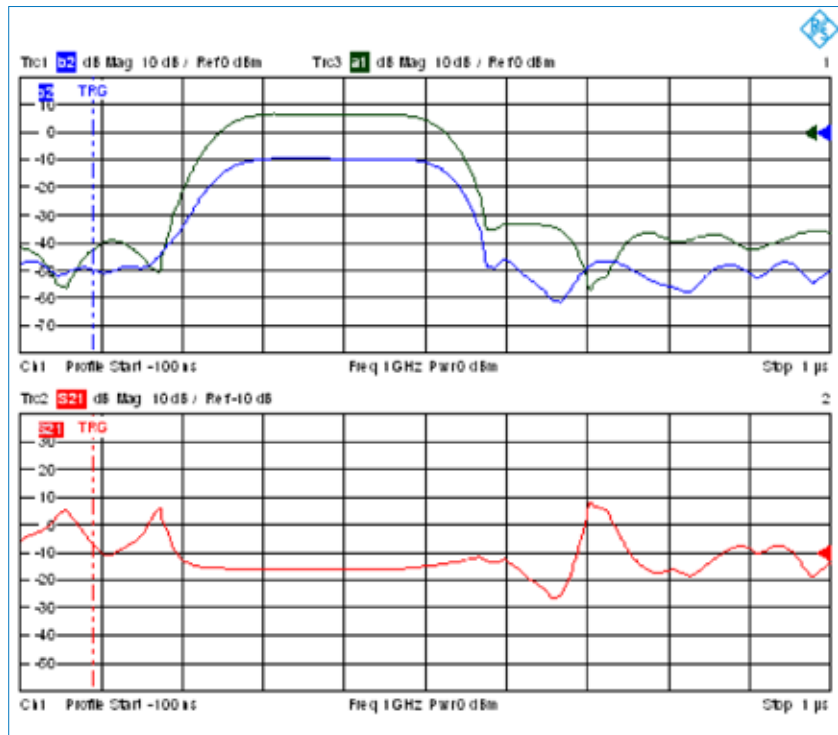

Pulse profile measurement; amplitudes (i.e. powers of the reference and the measurement channel) and S-parameter

- ¹⁾ The R&S®ZVA-K17 upgrade option may also be required, depending on the analyzer's manufacturing date.
- ²⁾ Selectable up to 30 MHz with restrictions.

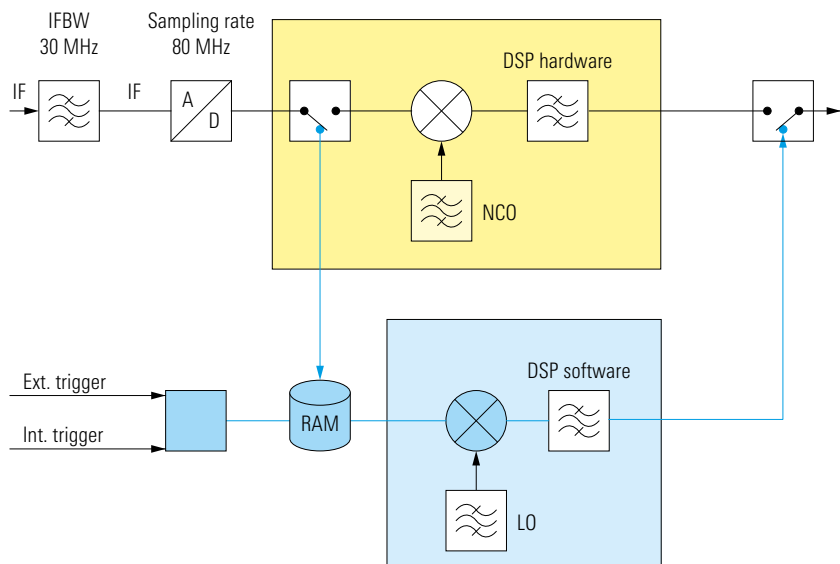

Principle of pulse profile measurements

Options

Designation	Type	Function
Oven Quartz (OCXO)	R&S® ZVAB-B4	Enhanced frequency accuracy
Time Domain (TDR)	R&S® ZVAB-K2	Location of discontinuities or determination of impedance characteristic versus time/length, reflection and transmission measurements, gating function for eliminating discontinuities, linear prediction function for enhanced resolution
Generator Step Attenuator for Port 1/2/3/4	R&S® ZVA8-B21/22/23/24 R&S® ZVA24-B21/22/23/24 R&S® ZVA40-B21/22/23/24 R&S® ZVA50-B21/22/23/24	Generator step attenuators for test ports 1 to 4; 70 dB in steps of 10 dB; $P_{\min} = <-100$ dBm (R&S® ZVA8, R&S® ZVA24, R&S® ZVA40) 50 dB in steps of 10 dB; $P_{\min} = <-100$ dBm (R&S® ZVA50)
Receiver Step Attenuator for Port 1/2/3/4	R&S® ZVA8-B31/32/33/34 R&S® ZVA24-B31/32/33/34 R&S® ZVA40-B31/32/33/34 R&S® ZVA50-B31/32/33/34	Receiver step attenuators for test ports 1 to 4; 35 dB in steps of 5 dB; $P_{\max} = 27$ dBm
Direct Generator/Receiver Access (all ports), 2-/4-Port Model	R&S® ZVA8-B16 R&S® ZVA24-B16 R&S® ZVA40-B16 R&S® ZVA50-B16	Direct access to the R&S® ZVA internal generators and receivers for all ports of the analyzer (internal couplers are bypassed)
Frequency Conversion	R&S® ZVA-K4	Measurements on frequency-converting DUTs: conversion gain, harmonics, and intermodulation measurements on mixers and amplifiers; R&S® ZVAB-B44 or VISA I/O BIB option is recommended for controlling external generators
5 MHz Receiver Bandwidth	R&S® ZVA-K17	Offers up to 5 MHz IF bandwidth, thus providing shorter measurement times for frequency, time, or CW sweeps; enhanced performance for point-in-pulse measurements
Pulsed Measurements	R&S® ZVA-K7	Enables pulse profile measurements: up to 3 ms recording of pulse profile versus time with 12.5 ns resolution; measurement of magnitude and phase of S-parameters; offers up to 30 MHz IF bandwidth; includes R&S® ZVA-K17
Pulsed Measurements	R&S® ZVA-B7	Enables pulse profile measurements: up to 25 ms recording of pulse profile versus time with 12.5 ns resolution; includes R&S® ZVA-K7
True Differential Measurements	R&S® ZVA-K6	Stimulation of balanced devices using true 180° and 0° phase-locked differential signals supplied by the two internal generators of the R&S® ZVA four-port model; measures mixed-mode S-parameters, phase, etc; supports -180° to +180° true phase and amplitude imbalance sweeps of the stimulus signals
USB-to-IEC/IEEE Adapter	R&S® ZVAB-B44	Adapter and driver software for controlling external generators by means of the R&S® ZVA via the GPIB interface; required, for example, for use with the R&S® ZVA-K4 frequency conversion option
Visa I/O Library	VISA I/O BIB	Software library for controlling external generators by means of the R&S® ZVA via the LAN interface; required, for example, for use with the R&S® ZVA-K4 frequency conversion option
Converter WR10, 75 GHz to 110 GHz	R&S® ZVA-Z110	Converts the frequency range of an R&S® ZVA24, R&S® ZVA40 or R&S® ZVA50 vector network analyzer to the range 75 GHz to 110 GHz. One or more external R&S® ZVA-Z110 converters may be required. Bidirectional measurements on two-port DUTs, for example, require two R&S® ZVA-Z110 converters. Additional requirements: cable sets, waveguide calibration kits, R&S® ZVA-K8 converter control software (for details refer to the R&S® ZVA-Z110 data sheet)

Standard functions (overview)

Two or four test ports, one generator for each pair of test ports	Integrated bidirectional RF test ports; test set configuration depends on analyzer model and is provided as standard in each case
Measured quantities	Complete S-parameter matrix, wave quantities, wave quantity ratios, impedances, admittances, Z- and Y-parameters of multiport DUTs, stability factors
Balanced measurements (standard mode)	Mixed-mode S-parameters, mixed-mode Z- and Y-parameters, impedances and admittances of balanced DUTs
Pulsed measurements	High PRF mode, point-in-pulse, pulse profile measurements with pulse duration of approx. 10 μ s to 100 μ s and longer, by means of CW or time sweep; use of R&S®ZVAxy-B16 and R&S®ZVA-K4 options recommended
Calibration techniques	TOSM, TRL/LRL, TOM, TRM, TNA, normalization, one-path two-port; UOSM for calibration with an unknown through-connection (includes adapter removal function) automatic calibration (R&S®ZV-Z51/-Z52/-Z53/-Z54)
Power calibration	Enhanced power accuracy; calibration of test sets and preamplifiers; for frequency and power sweeps; requires an external power meter; maximum convenience with R&S®NRP power sensors with USB interface
Power measurement and scalar network analysis	R&S®NRP power sensors can be connected directly to the USB ports and are treated like additional test inputs; display of power versus frequency or versus power; enables wideband scalar network analysis
Automatic level control (ALC)	Controls the output power by means of the signal fed to the reference channel; corrects preamplifier drift as well as power uncertainty due to mismatch; provides enhanced power accuracy and linearity
Active test set (PORT BIAS)	Input of DC power for supply of amplifiers via inner conductor of test port; requires external DC power supply
DC inputs	Measurement inputs for DC voltage, enabling PAE measurements
User support for calibration	Calibration manager; performance of selective calibration steps instead of complete recalibration; definition of calibration kits by means of equivalent circuit model or using S-parameters of calibration standards
Large number of diagrams, traces, and channels	More than 100 traces and channels can be created and assigned to diagrams as required
Preloading of setups; setup swap	Simultaneous loading of several instrument setups into RAM; fast switchover between instrument setups, manually or by IEC bus control
Segmented sweep, lin/log sweep	Optimization of sweeps for important DUT measurement parameters
Power sweep, compression measurements	50 dB power sweep range for compression measurements
CW mode	Sweeps with fixed power and frequency. Shortest measurement time less than 3.5 μ s per test point; for measuring pulsed components or settling times
Time sweep	Determination of measured quantities as a function of time
60001 points per trace (100001 points on request)	High sweep resolution, narrow test point grid
IF bandwidths 1 Hz to 1 MHz	Optimization of measurement speed and dynamic range
Online support functions	Context-sensitive online help; UNDO function for canceling the last user operations; Windows XP key for accessing the operating system; complete listing of current instrument setup including calibration
User guidance	Step-by-step guidance to desired instrument setup, including calibration if required (measurement wizard)
Convenient execution of control software	Execution of macros, as well as control or analysis programs, at a keystroke
Trace mathematics, equation editor	Functions for online computation of measured data using complex equations, for adjustments and for statistical evaluation (rms, MaxHold, etc)
Marker functions, trace statistics, limit lines	Ten markers per trace, individually configurable. Comprehensive analysis functions and online trace data evaluation. Generation of limit lines from traces, data import and export for limit lines
Trigger functions	Triggers for sweeps, sweep segments, test points, or partial measurements
Interfaces (2 \times LAN, 4 \times USB, IEC-BUS, FRQ-REF, MONITOR, USER CONTROL, DIGITAL INTERFACE, EXT TRIGGER)	Control of the R&S®ZVA; control of external devices or handlers by means of the R&S®ZVA; fast TTL handler and sequence control; connection of peripherals, e.g. printer or storage media (see also interface description); indication of measurement time
Embedding/deembedding	Inclusion of virtual matching networks, parasitic effects, etc; correction of the influence of test set components; parameterizable predefined networks and/or import of S-parameter files in order to define (matching) networks
Adapter removal	Enables calibration using different types of connectors in the reference planes, e.g. N \leftrightarrow 3.5 mm; this function is possible by applying the UOSM calibration technique, which allows an adapter with unknown parameters to be used as a through-connection ("Unknown Through"); O, S, and M calibration is required for the different connector types at both ends

Interface description

Interface	Function
LAN 1	Control of the R&S® ZVA or subnetwork with the R&S® ZVA as the master, 8-pin RJ-45 connector
LAN 2	Control of the R&S® ZVA or subnetwork with the R&S® ZVA as the master, 8-pin RJ-45 connector
IEC-BUS	Remote control of the R&S® ZVA
PORT BIAS	Input of DC power for supply of amplifiers via inner conductor of test port; one input and fuse per RF port; BNC connectors
USB	Standard 1.1 USB double port (for mouse, keyboard, printer, storage media, etc)
10 MHz REF	Reference frequency I/O: 10 MHz reference can be input from, or output to, external devices; BNC connector
DC MEAS	Measurement inputs for DC voltage and PAE measurements; input voltage ranges ± 1 V and ± 10 V; Mini DIN connectors; required cable: R&S® ZV-Z71 (option)
MONITOR	For external VGA monitor; standard VGA connector
USER CONTROL	TTL I/O signals: sweep status indication, pass/fail indication, indication of active test port, indication of active channel by channel bits, trigger signals for fast control of external devices, e.g. generators, handshake with handlers, sequence control without programming effort; 25-pin D-Sub connector
EXT TRIGGER	Input of external TTL trigger signal for starting a sweep, sweep segment, test point, or partial measurement; BNC connector



Rear view of the R&S® ZVA24

Ordering information

Designation	Type	Frequency range	Order No.
Base units¹⁾			
Vector Network Analyzer, 2 ports, 8 GHz, N	R&S®ZVA8	300 kHz to 8 GHz	1145.1110.08
Vector Network Analyzer, 4 ports, 8 GHz, N	R&S®ZVA8	300 kHz to 8 GHz	1145.1110.10
Vector Network Analyzer, 2 ports, 24 GHz, 3.5 mm	R&S®ZVA24	10 MHz to 24 GHz	1145.1110.24
Vector Network Analyzer, 4 ports, 24 GHz, 3.5 mm	R&S®ZVA24	10 MHz to 24 GHz	1145.1110.26
Vector Network Analyzer, 2 ports, 40 GHz, 2.4 mm	R&S®ZVA40	10 MHz to 40 GHz	1145.1110.43
Vector Network Analyzer, 2 ports, 40 GHz, 2.92 mm	R&S®ZVA40	10 MHz to 40 GHz	1145.1110.40
Vector Network Analyzer, 4 ports, 40 GHz, 2.4 mm	R&S®ZVA40	10 MHz to 40 GHz	1145.1110.45
Vector Network Analyzer, 4 ports, 40 GHz, 2.92 mm	R&S®ZVA40	10 MHz to 40 GHz	1145.1110.42
Vector Network Analyzer, 2 Ports, 50 GHz, 2,4 mm	R&S®ZVA50	10 MHz to 50 GHz	1145.1110.50
Vector Network Analyzer, 4 Ports, 50 GHz, 2,4 mm	R&S®ZVA50	10 MHz to 50 GHz	1145.1110.52
Options			
Direct Generator/Receiver Access, 2-Port Model, 8 GHz	R&S®ZVA8-B16	300 kHz to 8 GHz	1164.0209.08
Direct Generator/Receiver Access, 4-Port Model, 8 GHz	R&S®ZVA8-B16	300 kHz to 8 GHz	1164.0209.10
Direct Generator/Receiver Access, 2-Port Model, 24 GHz	R&S®ZVA24-B16	10 MHz to 24 GHz	1164.0209.24
Direct Generator/Receiver Access, 4-Port Model, 24 GHz	R&S®ZVA24-B16	10 MHz to 24 GHz	1164.0209.26
Direct Generator/Receiver Access, 2-Port Model, 40 GHz	R&S®ZVA40-B16	10 MHz to 40 GHz	1164.0209.40
Direct Generator/Receiver Access, 4-Port Model, 40 GHz	R&S®ZVA40-B16	10 MHz to 40 GHz	1164.0209.42
Direct Generator/Receiver Access for 2-Port Model 50 GHz	R&S®ZVA50-B16	10 MHz to 50 GHz	1164.0209.50
Direct Generator/Receiver Access for 4-Port Model 50 GHz	R&S®ZVA50-B16	10 MHz to 50 GHz	1164.0209.52
Generator Step Attenuator, Port 1, for R&S®ZVA8	R&S®ZVA8-B21	300 kHz to 8 GHz	1164.0009.02
Generator Step Attenuator, Port 2, for R&S®ZVA8	R&S®ZVA8-B22	300 kHz to 8 GHz	1164.0015.02
Generator Step Attenuator, Port 3, for R&S®ZVA8	R&S®ZVA8-B23	300 kHz to 8 GHz	1164.0021.02
Generator Step Attenuator, Port 4, for R&S®ZVA8	R&S®ZVA8-B24	300 kHz to 8 GHz	1164.0038.02
Generator Step Attenuator, Port 1, for R&S®ZVA24	R&S®ZVA24-B21	10 MHz to 24 GHz	1164.0109.02
Generator Step Attenuator, Port 2, for R&S®ZVA24	R&S®ZVA24-B22	10 MHz to 24 GHz	1164.0115.02
Generator Step Attenuator, Port 3, for R&S®ZVA24	R&S®ZVA24-B23	10 MHz to 24 GHz	1164.0121.02
Generator Step Attenuator, Port 4, for R&S®ZVA24	R&S®ZVA24-B24	10 MHz to 24 GHz	1164.0138.02
Generator Step Attenuator, Port 1, for R&S®ZVA40	R&S®ZVA40-B21	10 MHz to 40 GHz	1302.5409.02
Generator Step Attenuator, Port 2, for R&S®ZVA40	R&S®ZVA40-B22	10 MHz to 40 GHz	1302.5415.02
Generator Step Attenuator, Port 3, for R&S®ZVA40	R&S®ZVA40-B23	10 MHz to 40 GHz	1302.5421.02
Generator Step Attenuator, Port 4, for R&S®ZVA40	R&S®ZVA40-B24	10 MHz to 40 GHz	1302.5438.02
Generator Step Attenuator, Port 1, for R&S®ZVA50	R&S®ZVA50-B21	10 MHz to 50 GHz	1305.5616.02
Generator Step Attenuator, Port 2, for R&S®ZVA50	R&S®ZVA50-B22	10 MHz to 50 GHz	1305.5622.02
Generator Step Attenuator, Port 3, for R&S®ZVA50	R&S®ZVA50-B23	10 MHz to 50 GHz	1305.5639.02
Generator Step Attenuator, Port 4, for R&S®ZVA50	R&S®ZVA50-B24	10 MHz to 50 GHz	1305.5645.02
Receiver Step Attenuator, Port 1, for R&S®ZVA8	R&S®ZVA8-B31	300 kHz to 8 GHz	1164.0044.02
Receiver Step Attenuator, Port 2, for R&S®ZVA8	R&S®ZVA8-B32	300 kHz to 8 GHz	1164.0050.02
Receiver Step Attenuator, Port 3, for R&S®ZVA8	R&S®ZVA8-B33	300 kHz to 8 GHz	1164.0067.02
Receiver Step Attenuator, Port 4, for R&S®ZVA8	R&S®ZVA8-B34	300 kHz to 8 GHz	1164.0073.02
Receiver Step Attenuator, Port 1, for R&S®ZVA24	R&S®ZVA24-B31	10 MHz to 24 GHz	1164.0144.02
Receiver Step Attenuator, Port 2, for R&S®ZVA24	R&S®ZVA24-B32	10 MHz to 24 GHz	1164.0150.02
Receiver Step Attenuator, Port 3, for R&S®ZVA24	R&S®ZVA24-B33	10 MHz to 24 GHz	1164.0167.02
Receiver Step Attenuator, Port 4, for R&S®ZVA24	R&S®ZVA24-B34	10 MHz to 24 GHz	1164.0173.02
Receiver Step Attenuator, Port 1, for R&S®ZVA40	R&S®ZVA40-B31	10 MHz to 40 GHz	1302.5444.02

Designation	Type	Frequency range	Order No.
Receiver Step Attenuator, Port 2, for R&S® ZVA40	R&S® ZVA40-B32	10 MHz to 40 GHz	1302.5450.02
Receiver Step Attenuator, Port 3, for R&S® ZVA40	R&S® ZVA40-B33	10 MHz to 40 GHz	1302.5467.02
Receiver Step Attenuator, Port 4, for R&S® ZVA40	R&S® ZVA40-B34	10 MHz to 40 GHz	1302.5473.02
Receiver Step Attenuator, Port 1, for R&S® ZVA50	R&S® ZVA50-B31	10 MHz to 50 GHz	1305.5716.02
Receiver Step Attenuator, Port 2, for R&S® ZVA50	R&S® ZVA50-B32	10 MHz to 50 GHz	1305.5722.02
Receiver Step Attenuator, Port 3, for R&S® ZVA50	R&S® ZVA50-B33	10 MHz to 50 GHz	1305.5739.02
Receiver Step Attenuator, Port 4, for R&S® ZVA50	R&S® ZVA50-B34	10 MHz to 50 GHz	1305.5745.02
Converter WR10 (one unit)	R&S® ZVA-Z110	75 GHz to 110 GHz	1307.7000.02
Converter Control Software ⁵⁾	R&S® ZVA-K8		1307.7022.02
Oven Quartz (OCXO)	R&S® ZVAB-B4		1164.1757.02
Time Domain (TDR)	R&S® ZVAB-K2		1164.1657.02
Frequency Conversion ²⁾	R&S® ZVA-K4		1164.1863.02
Pulsed Measurements, 3 ms recording time, for all R&S® ZVA ³⁾	R&S® ZVA-K7		1164.1511.02
Pulsed Measurements, 25 ms recording time, for all 2-port R&S® ZVA ⁴⁾	R&S® ZVA-B7		1164.1492.02
Pulsed Measurements, 25 ms recording time, for all 4-port R&S® ZVA ⁴⁾	R&S® ZVA-B7		1164.1492.03
Upgrade of Trigger Hardware ⁶⁾	R&S® ZVA-UK7		1164.1463.02
5 MHz Receiver Bandwidth	R&S® ZVA-K17		1164.1070.02
True Differential Measurements ⁷⁾	R&S® ZVA-K6		1164.1540.02
USB-to-IEC/IEEE Adapter	R&S® ZVAB-B44		1302.5544.02
Visa I/O Library	VISA I/O BIB		1161.8473.02
Extras			
Calibration Kits			
Calibration Kit, N, 50 Ω	R&S® ZCAN	0 Hz to 3 GHz	0800.8515.52
Calibration Kit, N, 50 Ω	R&S® ZV-Z21	0 Hz to 18 GHz	1085.7099.02
Calibration Kit, 3.5 mm	R&S® ZV-Z32	0 Hz to 26.5 GHz	1128.3501.02
Calibration Kit, 3.5 mm (with sliding matches)	R&S® ZV-Z33	0 Hz to 26.5 GHz	1128.3518.02
TRL Supplementary Calibration Kit, N, 50 Ω	R&S® ZV-Z26	0.2 GHz to 18 GHz	1085.7318.02
TRL Supplementary Calibration Kit, 3.5 mm	R&S® ZV-Z27	0.4 GHz to 26.5 GHz	1085.7401.02
Calibration Kit, 2.92 mm	R&S® ZV-Z34	0 GHz to 40 GHz	1128.3530.02
Calibration Kit, 2.92 mm (with sliding matches)	R&S® ZV-Z35	0 GHz to 40 GHz	1128.3547.02
Calibration Kit, 2.4 mm	R&S® ZV-Z36	0 Hz to 50 GHz	1305.5900.02
Calibration Kit, N (m), 50 Ω	R&S® ZV-Z121	0 Hz to 8 GHz	1164.0496.02
Calibration Kit, N (f), 50 Ω	R&S® ZV-Z121	0 Hz to 8 GHz	1164.0496.03
Calibration Kit, 3.5 mm (m), 50 Ω	R&S® ZV-Z132	0 Hz to 8 GHz	1164.1092.02
Calibration Kit, 3.5 mm (f), 50 Ω	R&S® ZV-Z132	0 Hz to 8 GHz	1164.1092.03
Waveguide Calibration Kit WR10 (without sliding match)	R&S® ZV-WR10	75 GHz to 110 GHz	1307.7100.10
Waveguide Calibration Kit WR10 (with sliding match)	R&S® ZV-WR10	75 GHz to 110 GHz	1307.7100.11
Calibration Unit, 4 Ports, 3.5 mm (f), 8 GHz	R&S® ZV-Z51	300 kHz to 8 GHz	1164.0515.30
Calibration Unit, 4 Ports, N (f), 8 GHz	R&S® ZV-Z51	300 kHz to 8 GHz	1164.0515.70
Calibration Unit, 4 Ports, 3.5 mm (f), 24 GHz	R&S® ZV-Z52	10 MHz to 24 GHz	1164.0521.30
Calibration Unit, 2 Ports, N (f), 18 GHz	R&S® ZV-Z53	300 kHz to 18 GHz	1164.0473.72
Calibration Unit, 2 Ports, 2.92 mm (f)	R&S® ZV-Z54	10 MHz to 40 GHz	1164.0467.92

Ordering information

Designation	Type	Frequency range	Order No.
Test Cable			
N (m)/N (m), 50 Ω, 0.6 m/1 m ⁸⁾	R&S® ZV-Z91	0 Hz to 18 GHz	1301.7572.25/38
N (m)/3.5 mm (m), 50 Ω, 0.6 m/1 m ⁸⁾	R&S® ZV-Z92	0 Hz to 18 GHz	1301.7589.25/38
3.5 mm (f)/3.5 mm (m), 0.6 m/1 m ⁸⁾	R&S® ZV-Z93	0 Hz to 26.5 GHz	1301.7595.25/38
2.92 mm (f)/2.92 mm (m), 0.6 m/1 m ⁸⁾	R&S® ZV-Z95	0 Hz to 40 GHz	1301.7608.25/38
2.4 mm (f) / 2.4 mm (m), 0.6 m	R&S® ZV-Z97	0 Hz to 50 GHz	1301.7637.25
N (m)/N (m), 50 Ω, 0.6 m/0.9 m ⁸⁾	R&S® ZV-Z191	0 Hz to 18 GHz	1306.4507.24/36
N (m)/3.5 mm (m), 50 Ω, 0.6 m/0.9 m ⁸⁾	R&S® ZV-Z192	0 Hz to 18 GHz	1306.4513.24/36
3.5 mm (f)/3.5 mm (m), 0.6 m/0.9 m ⁸⁾	R&S® ZV-Z193	0 Hz to 26.5 GHz	1306.4520.24/36
2.92 mm (f)/2.92 mm (m), 0.6 m/0.9 m ⁸⁾	R&S® ZV-Z195	0 Hz to 40 GHz	1306.4536.24/36
Sliding Matches			
N (m), 50 Ω	R&S® ZV-Z41	1.7 GHz to 18 GHz	1085.8095.02
N (f), 50 Ω	R&S® ZV-Z41	1.7 GHz to 18 GHz	1085.8095.03
3.5 mm (m/f pair)	R&S® ZV-Z42	2 GHz to 26.5 GHz	1128.3524.02
2.92 mm (m/f pair)	R&S® ZV-Z44	4 GHz to 40 GHz	1128.3553.02
Hardware and measurement add-ons			
USB Keyboard	R&S® PSL-Z2		1157.6870.04
USB Mouse	R&S® PSL-Z10		1157.7060.03
Cable for DC Input	R&S® ZV-Z71		1164.1005.02
19" Rack Adapter	R&S® ZZA-611		1096.3302.00
Removable Flash Disk (for FMR6/5) ⁸⁾	R&S® ZVAB-B18		1164.0715.02
2nd Removable Flash Disk	R&S® ZVAB-B19		1164.1111.02
Removable Flash Disk (for FMR7/3, FMR7/6)	R&S® ZVAB-B18		1164.0715.03
Upgrade Kit for Control Unit (FMR6/5 to FMR7/6) ⁸⁾	R&S® ZVx-U1		1305.4610.02
Upgrade Kit for Control Unit (FMR7/3 to FMR7/6) ¹⁾	R&S® ZVAB-U76		1305.4610.04
Control Unit FMR7/6 ex factory	R&S® ZVAB-B76		1305.4610.03
Manual (in printed form)			1145.1084.12

¹⁾ Operating manual on CD ROM and quick start guide supplied as standard with the R&S® ZVA.

²⁾ The R&S® ZVAB-B44 option is required for controlling external generators via GPIB; the VISA I/O BIB option is required for controlling external generators via LAN.

³⁾ Includes ZVA-K17

⁴⁾ Includes ZVA-K7

⁵⁾ Includes ZVA-K4

⁶⁾ Depending on the manufacturing date of the R&S® ZVA, the R&S® ZVA-K7 option may require the R&S® ZVA-UK7 option. Contact your local Rohde & Schwarz office details.

⁷⁾ Requires R&S® ZVA four-port model.

⁸⁾ One cable.

⁹⁾ All R&S® ZVA analyzers will be equipped as standard with an FMR7/3 control unit as of September 2007. The FMR7/6 control unit with higher performance can be installed optionally.

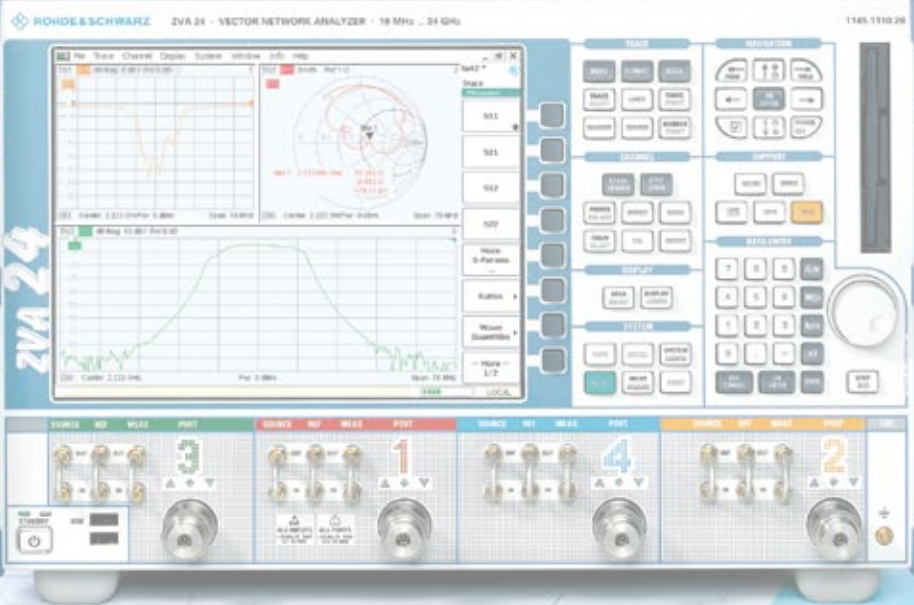



For data sheet, see PD 5213.5680.22
and www.rohde-schwarz.com
(search term: ZVA)



ROHDE & SCHWARZ

www.rohde-schwarz.com

Europe: +49 1805 12 4242, customersupport@rohde-schwarz.com
Americas: 1-888-837-8772, customer.support@rsa.rohde-schwarz.com
Asia: +65 65 130 488, customersupport.asia@rohde-schwarz.com