



ABN 43 064 478 842

231 Osborne Avenue Clayton South, VIC 3169
PO Box 1548, Clayton South, VIC 3169
t 03 9265 7400 f 03 9558 0875
freecall 1800 680 680
www.tmgtestequipment.com.au

Test & Measurement

- > sales
- > rentals
- > calibration
- > repair
- > disposal

Complimentary Reference Material

This PDF has been made available as a complimentary service for you to assist in evaluating this model for your testing requirements.

TMG offers a wide range of test equipment solutions, from renting short to long term, buying refurbished and purchasing new. Financing options, such as Financial Rental, and Leasing are also available on application.

TMG will assist if you are unsure whether this model will suit your requirements.

Call TMG if you need to organise repair and/or calibrate your unit.

If you click on the "Click-to-Call" logo below, you can call us for FREE!

TMG Corporate Website

TMG Products Website



Click-to-Call
TMG Now



Product Lifecycle Management System

Disclaimer:

All trademarks appearing within this PDF are trademarks of their respective owners.



Instructions

Tektronix

**P6248
1.7 GHz (Typical)
Differential Probe**

071-0566-03

Copyright © Tektronix, Inc. All rights reserved.

Tektronix products are covered by U.S. and foreign patents, issued and pending. Information in this publication supercedes that in all previously published material. Specifications and price change privileges reserved.

Tektronix, Inc., P.O. Box 500, Beaverton, OR 97077

TEKTRONIX, TEK, and TEKPROBE are registered trademarks of Tektronix, Inc.

KlipChip, TwinFoot, TwinTip, and VariTip are trademarks of Tektronix, Inc.

WARRANTY

Tektronix warrants that the products that it manufactures and sells will be free from defects in materials and workmanship for a period of one (1) year from the date of shipment. If a product proves defective during this warranty period, Tektronix, at its option, either will repair the defective product without charge for parts and labor, or will provide a replacement in exchange for the defective product.

In order to obtain service under this warranty, Customer must notify Tektronix of the defect before the expiration of the warranty period and make suitable arrangements for the performance of service. Customer shall be responsible for packaging and shipping the defective product to the service center designated by Tektronix, with shipping charges prepaid. Tektronix shall pay for the return of the product to Customer if the shipment is to a location within the country in which the Tektronix service center is located. Customer shall be responsible for paying all shipping charges, duties, taxes, and any other charges for products returned to any other locations.

This warranty shall not apply to any defect, failure or damage caused by improper use or improper or inadequate maintenance and care. Tektronix shall not be obligated to furnish service under this warranty a) to repair damage resulting from attempts by personnel other than Tektronix representatives to install, repair or service the product; b) to repair damage resulting from improper use or connection to incompatible equipment; c) to repair any damage or malfunction caused by the use of non-Tektronix supplies; or d) to service a product that has been modified or integrated with other products when the effect of such modification or integration increases the time or difficulty of servicing the product.

THIS WARRANTY IS GIVEN BY TEKTRONIX IN LIEU OF ANY OTHER WARRANTIES, EXPRESS OR IMPLIED. TEKTRONIX AND ITS VENDORS DISCLAIM ANY IMPLIED WARRANTIES OF MERCHANTABILITY OR FITNESS FOR A PARTICULAR PURPOSE. TEKTRONIX' RESPONSIBILITY TO REPAIR OR REPLACE DEFECTIVE PRODUCTS IS THE SOLE AND EXCLUSIVE REMEDY PROVIDED TO THE CUSTOMER FOR BREACH OF THIS WARRANTY. TEKTRONIX AND ITS VENDORS WILL NOT BE LIABLE FOR ANY INDIRECT, SPECIAL, INCIDENTAL, OR CONSEQUENTIAL DAMAGES IRRESPECTIVE OF WHETHER TEKTRONIX OR THE VENDOR HAS ADVANCE NOTICE OF THE POSSIBILITY OF SUCH DAMAGES.

Table of Contents

General Safety Summary	iii
Preface	v
Contacting Tektronix	vi
Getting Started	1
Features and Accessories	1
Installation	8
Instruments with the TEKPROBE Interface (Tektronix TDS 400, 500, 600, and 700 Series Oscilloscopes)	9
Instruments without the TEKPROBE Interface	9
Operating Basics	11
Input Voltage Limits	11
Maximum Input Voltage	11
Common-Mode Signal Range	11
Differential-Mode Signal Range	12
Attenuation Settings	12
Probe Grounding	12
Input Impedance and Probe Loading	14
Common-Mode Rejection	15
Probing Techniques to Maximize CMRR	15
Reference	17
Problems with Single-Ended Measurements	17
Differential Measurements	17
Common-Mode Rejection Ratio	18
Assessing CMRR Error	18
Input Impedance Effects on CMRR	19
Extending the Input Leads	19
Extending the Ground Lead	20
Extending the Probe Output	20
Terminating the Probe	20
Effect of Extending the Output Cable	21
Using the Probe with Other Instruments	21
Specifications	23
Warranted Characteristics	23
Typical Characteristics	25
Nominal Characteristics	28

List of Figures

Figure 1: Input connector of TEKPROBE interface	8
Figure 2: Using the short ground contact	13
Figure 3: Typical probe input model	14
Figure 4: Using the input lead accessories to achieve high CMRR	15
Figure 5: Using the TwinFoot adapter	16
Figure 6: Simplified model of a differential amplifier	18
Figure 7: Twisting the Input Leads	20
Figure 8: Typical Common-Mode Rejection Ratio (B1 and B10 attenuation)	26
Figure 9: Typical differential input impedance versus frequency	26
Figure 10: Probe head and compensation box dimensions .	27

General Safety Summary

Review the following safety precautions to avoid injury and prevent damage to this product or any products connected to it. To avoid potential hazards, use this product only as specified.

Only qualified personnel should perform service procedures.

To Avoid Fire or Personal Injury

Connect and Disconnect Properly. Connect the probe output to the measurement instrument before connecting the probe to the circuit under test. Disconnect the probe input and the probe ground from the circuit under test before disconnecting the probe from the measurement instrument.

Observe All Terminal Ratings. To avoid fire or shock hazard, observe all ratings and markings on the product. Consult the product manual for further ratings information before making connections to the product.

Connect the ground lead of the probe to earth ground only.

Do Not Operate Without Covers. Do not operate this product with covers or panels removed.

Do Not Operate With Suspected Failures. If you suspect there is damage to this product, have it inspected by qualified service personnel.

Do Not Operate in Wet/Damp Conditions.

Do Not Operate in an Explosive Atmosphere.

Keep Product Surfaces Clean and Dry.

Safety Terms and Symbols

Terms in This Manual. These terms may appear in this manual:



WARNING. *Warning statements identify conditions or practices that could result in injury or loss of life.*



CAUTION. *Caution statements identify conditions or practices that could result in damage to this product or other property.*

Terms on the Product. These terms may appear on the product:

DANGER indicates an injury hazard immediately accessible as you read the marking.

WARNING indicates an injury hazard not immediately accessible as you read the marking.

CAUTION indicates a hazard to property including the product.

Symbols on the Product. These symbols may appear on the product:



CAUTION
Refer to Manual



Protective Ground
(Earth) Terminal



Preface

This manual contains instructions and specifications for using the P6248 differential probe.

Related Manuals

For performance verification procedures, adjustment procedures, a list of replaceable parts, and other service information, refer to the *P6248 Service Manual* (071-0573-XX).

Contacting Tektronix

Phone	1-800-833-9200*
Address	Tektronix, Inc. Department or name (if known) 14200 SW Karl Braun Drive P.O. Box 500 Beaverton, OR 97077 USA
Web site	www.tektronix.com
Sales support	1-800-833-9200, select option 1*
Service support	1-800-833-9200, select option 2*
Technical support	Email: techsupport@tektronix.com 1-800-833-9200, select option 3* 6:00 a.m. - 5:00 p.m. Pacific time

* **This phone number is toll free in North America. After office hours, please leave a voice mail message. Outside North America, contact a Tektronix sales office or distributor; see the Tektronix web site for a list of offices.**

Getting Started

The P6248 is a high-bandwidth differential probe with the TEK-PROBE interface. The P6248 probe has a bandwidth of 1.5 GHz (1.7 GHz typical). The probe has low circuit loading, high common-mode rejection, and comes with accessories that accommodate a wide variety of applications.

The TEKPROBE interface is standard on Tektronix TDS series oscilloscopes. The Tektronix 1103 TEKPROBE Power Supply can be used for instruments without the TEKPROBE interface (refer to page 7).

Features and Accessories

Table 1 shows the features and standard accessories of the P6248 differential probe.

Table 1: P6248 features and standard accessories

Feature/Accessory	Description
	<p>TEKPROBE interface. The TEKPROBE interface supplies power to the probe, selects the correct display scaling, and automatically sets the 50 Ω termination on the oscilloscope input.</p> <p>If your oscilloscope does not have the TEKPROBE interface, you can use the optional 1103 power supply (refer to page 7).</p>
<p>ATTENUATION $\div 10$ <input type="checkbox"/> $\div 1$</p>	<p>Probe attenuation. The attenuation switch selects either divide by 1 ($\div 1$) or divide by 10 ($\div 10$).</p>

Table 1: P6248 features and standard accessories (Cont.)



Feature/Accessory	Description
	<p>Input connections. The (+), (-), and ground connections of the probe head accept the standard and optional probe accessories. You can also plug the head directly onto a pair of 0.025-inch square pins that have the standard spacing of 0.100-inch on center.</p> <p>CAUTION: To avoid damaging the input connectors, do not insert anything larger than a 0.025-inch square pin into the inputs. To prolong the life of the connectors, use the tip saver or smooth, gold-plated pins only.</p>
	<p>Instrument case. The instrument case protects the probe from harsh environments and provides room for storing optional accessories.</p> <p>Replacement part number (P6248): 016-1879-XX</p>
	<p>Calibration certificate. A certificate of traceable calibration is provided with every instrument shipped.</p>
	<p>Instructions. Provides instructions for operating the P6248 differential probe.</p> <p>Replacement part number: 071-0566-XX</p>

Table 1: P6248 features and standard accessories (Cont.)

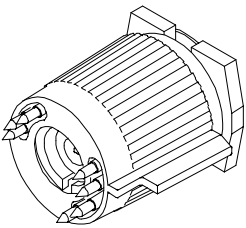
Feature/Accessory	Description
	<p>Service manual. Provides procedures for verifying the performance, adjusting, and maintaining the P6248 differential probe.</p> <p>Replacement part number: 071-0573-XX</p>
	<p>Probe tip accessory kit. This kit contains the accessories listed below, in a plastic case. For more information on the individual accessories, refer to Table 2 on page 4.</p> <ul style="list-style-type: none"> 10 Color marker bands 2 Y-lead adapters 4 Short ground leads 2 Long ground leads 10 Short ground contacts 6 Spring-loaded ground pin 4 TwinTip adapters 5 Longhorn via adapters 8 Straight tip adapters 8 VariTip adapters 4 TwinFoot adapters 2 Tip savers 4 SMT KlipChip adapters 1 Probe-tip-to-BNC-adapter <p>Replacement part number: 020-2328-XX</p>

Table 2 describes the contents of the probe tip accessory kit.

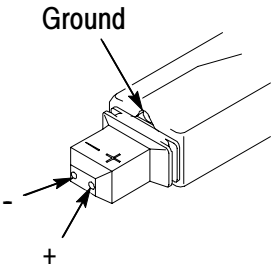
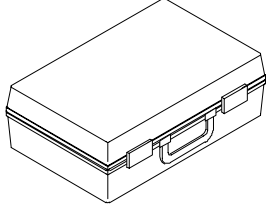
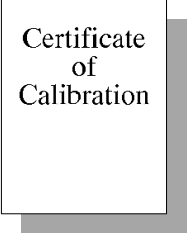
Table 2: P6248 Probe tip accessory kit contents

Accessory	Description
 <p>Color marker bands</p>	<p>Color marker bands. Attach matching pairs of the color marker bands onto the cable at the head and compensation box of each probe. The marker bands enable quick verification of which probe is connected to which instrument channel.</p> <p>Replacement part number: 016-1315-00 (package of 10)</p>
	<p>Lead set accessory kit. Includes (2) Y-lead adapters, (4) three-inch ground leads and (2) six-inch ground leads</p> <p>Replacement part number: 196-3462-00</p> <p>Y-lead adapter. The Y-lead adapter plugs directly into the probe. The socketed ends of the leads may be connected to the probe tips and accessories, or fitted onto 0.025-inch pins.</p> <p>Ground leads. Use the ground leads for connecting the probe ground to the circuit. The socketed end of the lead may be connected to the probe tips and accessories, or fitted onto 0.025-inch pins.</p>
	<p>Short ground contact. Use the short ground lead for probing small geometry components that have a nearby ground point. The ground easily connects to adjacent square pins when the probe is plugged directly onto 0.025-inch square pins (0.100-inch spacing). See Figure 2 on page 13.</p> <p>Replacement part number: 016-1783-00 (package of 10)</p>
	<p>Spring-loaded ground pin. Use the spring-loaded ground when probing components that have a nearby ground point.</p> <p>Replacement part number: 016-1782-00 (package of 6)</p>

Table 2: P6248 Probe tip accessory kit contents (Cont.)

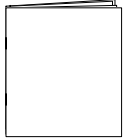
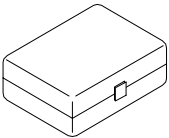
Accessory	Description
	<p>TwinTip adapter. This accessory provides two adjustable tips for probing connections that are close to each other.</p> <p>Replacement part number: 016-1786-00 (package of 4)</p>
	<p>Longhorn via adapter. This accessory is similar to the TwinTip adapter, but it has finer pins for probing smaller holes. Use this accessory for probing circuit board through-holes (vias).</p> <p>Replacement part number: 016-1780-00 (package of 5)</p>
	<p>Straight tip adapter. The straight tip adapters plug directly into the probe and allow you to take measurements from two points spaced 0.100 inches apart. Use the straight tip adapters when you need to measure fast waveforms that may be affected by the longer length of other adapters.</p> <p>Replacement part number: 016-1891-00 (package of 8)</p>
	<p>VariTip adapter. The VariTip adapters plug into the probe and allow you to measure two test points spaced between 0.020 and 0.180 inches apart. Use tweezers to adjust the spacing between the pins.</p> <p>Use the VariTip adapters to probe waveforms that have fast rise times. The short length of the VariTip adapters minimize the effects of increased probe tip inductance and capacitance on your measurements.</p> <p>Replacement part number: 016-1890-00 (package of 8)</p>
	<p>TwinFoot adapter. Use the TwinFoot adapter to probe two adjacent leads on a surface-mount integrated circuit. Flexible fingers adapt to a range of lead spacings. See Figure 5 on page 16.</p> <p>Replacement part number: 016-1785-00 (package of 4)</p>

Table 2: P6248 Probe tip accessory kit contents (Cont.)

Accessory	Description
	<p>Tip saver. Use the tip saver to prolong the life of your probe tip contacts. The tip saver connects to the probe and accepts the probe tip accessories, bearing the wear of repeated connections of different probe tips.</p> <p>Replacement part number: 016-1781-00 (package of 2)</p>
	<p>SMT KlipChip adapters. Use this accessory to probe the leads on dual-in-line packages (DIP).</p> <p>Replacement part number: 206-0364-XX</p>
	<p>Probe-tip-to-BNC adapter. This accessory adapts the probe to a BNC connector.</p> <p>Replacement part number: 679-4094-00</p>

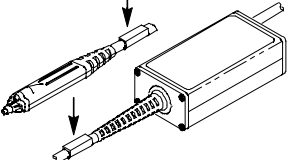
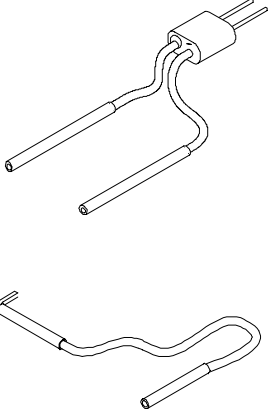
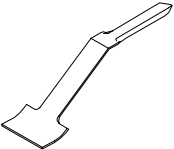
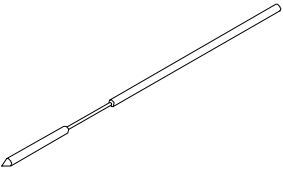
Table 3 shows the optional accessories that you can order for the P6248 differential probe.

Table 3: Optional accessories and instrument options

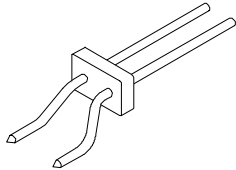
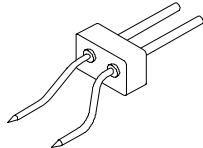
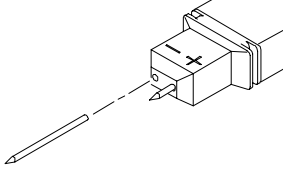
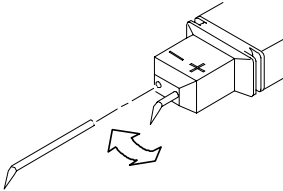
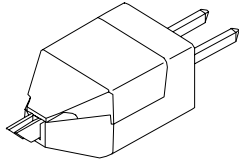
Accessory/Option	Description
	<p>1103 Power supply. Order the 1103 power supply for instruments that do not have the TEKPROBE Interface. Power cord options are available for the following countries or regions.</p> <p>Standard. North America and Japan</p> <p>Option A1. European</p> <p>Option A2. UK</p> <p>Option A3. Australia</p> <p>Option A5. Switzerland</p>
	<p>50 Ω termination. Terminates the output of the 1103 power supply to the required 50 Ω if the oscilloscope does not have a 50 Ω input setting. Order 011-0049-01.</p> <p>50 Ω BNC cable. Connects to the 1103 output. Replacement part number: 012-0076-00</p>
	<p>IEEE1394 Adapter. The IEEE1394 Adapter allows you to probe signals on the bus, external to system enclosures, without disturbing system operation. The adapter maintains a balanced 55 Ω signal path and can be used in both single-ended and differential modes.</p> <p>Replacement part number: 679-5027-00</p>
	<p>Micro KlipChip adapters. Use the adapters to probe the leads on integrated circuits that are surface-mounted.</p> <p>Replacement part number: SMK4 (package of 4)</p>

Table 3: Optional accessories and instrument options (Cont.)

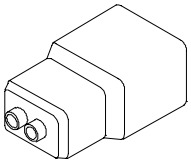
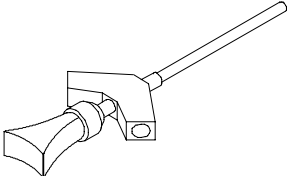
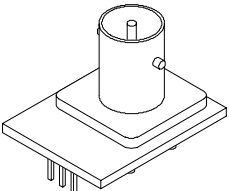
Accessory/Option	Description
	<p>Adjustment tool. Use for making internal adjustments to the probe. Order 003-0675-01.</p>
	<p>Calibration data (Option 95). Option 95, which must be ordered at the time of purchase, documents the measurements taken during calibration.</p>

Installation

Before you connect the output of the P6248 differential probe, determine whether or not your oscilloscope has a TEKPROBE interface. See Figure 1.

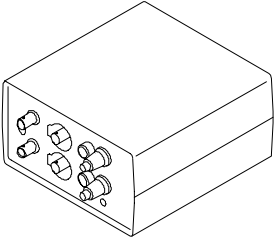
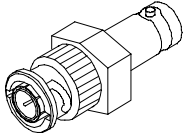
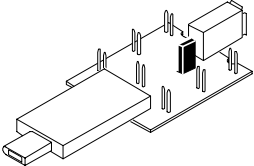
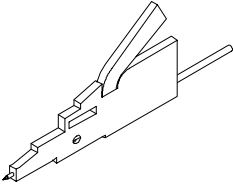
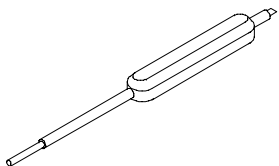
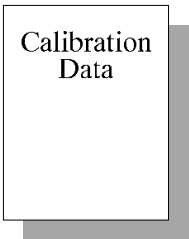
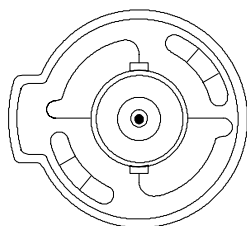

Figure 1: Input connector of TEKPROBE interface

Instruments with the TEKPROBE Interface (Tektronix TDS 400, 500, 600, and 700 Series Oscilloscopes)

On instruments that have the TEKPROBE interface, simply connect the probe to the input. The TEKPROBE interface provides power, selects the correct display scaling, and automatically sets the 50 Ω termination on the oscilloscope input.

NOTE. *TDS 400 and TDS 400A series oscilloscopes do not interpret the scale factor coding of the P6248 differential probe. This problem is only apparent when the probe is in the $\div 1$ position. To correct for this problem, divide the measurement (or scale factor) by 10 when you use the probe in the $\div 1$ position.*

Instruments without the TEKPROBE Interface

On instruments that do not have the TEKPROBE interface, you must order the optional 1103 power supply (refer to page 7). Each 1103 can supply power for two probes. The input of the oscilloscope must also terminate into 50 Ω . Refer to page 20 for information on the effects of extending the output of the probe.

When you set the attenuation of the probe, you must factor that attenuation into your measurement. For example, if the probe is set at $\div 10$ and the instrument displays a 0.2 V_{p-p} signal, the actual amplitude of the signal is 2 V_{p-p}.

Operating Basics

This section discusses operating considerations and probing techniques. For more detailed information about differential measurements and common-mode rejection ratio (CMRR), see the *Reference* section on page 17.

Input Voltage Limits

The P6248 differential probe is designed to probe low-voltage circuits. Before probing a voltage, take into account the limits for maximum input voltage, the common-mode signal range, and the differential-mode signal range.

Maximum Input Voltage

The maximum input voltage is the maximum voltage to ground that the inputs can withstand without damaging the input circuitry of the probe.



CAUTION. To avoid damaging the inputs of the P6248 differential probe, do not apply more than ± 25 V (DC + peak AC) between each input and ground.

Common-Mode Signal Range

The common-mode signal range is the maximum voltage that you can apply to each input, with respect to earth ground, without saturating the input circuitry of the probe. A common-mode voltage that exceeds the common-mode signal range may produce an erroneous output waveform even when the differential-mode specification is met. For *Specifications*, refer to page 23.

To verify the common-mode signal is within specification, set the probe to $\div 10$, temporarily connect one of the probe inputs to ground, and connect the other probe input to one output of the

differential signal. Repeat the procedure to test the other output of the differential signal.

Differential-Mode Signal Range

The differential-mode signal range is the maximum voltage difference between the (+) and (-) inputs that the probe can accept without distorting the signal. The distortion from a voltage that is too large can result in an invalid measurement. For *Specifications*, refer to page 23.

Attenuation Settings

The differential probe has two attenuation settings: $\div 1$ and $\div 10$. The $\div 1$ setting provides the best signal-to-noise performance with low amplitude signals. The $\div 10$ setting increases the differential-mode signal range by a factor of 10.

Probe Grounding

In addition to the (+) and (-) inputs on the probe head, there is also a ground (common) input. (See Figures 2 and 3.)



CAUTION. *To avoid damaging the circuitry under test, connect the probe ground (common) to a ground-reference point only.*

You can use the probe to take a differential measurement regardless of whether or not the ground (common) is connected.

There are some applications that may require a ground reference connection to maintain measurement accuracy. Generally this is necessary when probing circuits which are fully isolated from ground such as battery operated devices. In most applications, however, the common-mode impedance to ground is greater than the differential impedance. Hence, adding the probe ground lead does not improve the high-frequency performance of the measurement.

In addition to the 6-inch ground lead, there are other ground lead accessories that are useful in certain applications. Figure 2 shows how to use the short ground contact. Figure 4 on page 15 shows the spring-loaded ground pin.

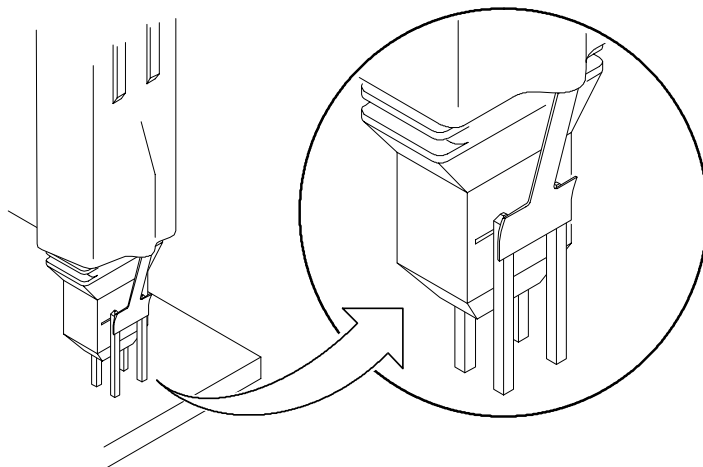

Figure 2: Using the short ground contact

Input Impedance and Probe Loading

When you connect the probe inputs to a circuit, you are introducing a new resistance, capacitance, and inductance into the circuit. Each input of the P6248 differential probe has a characteristic input impedance of $100\text{ k}\Omega$ to ground in parallel with less than 1 pF . See Figure 3.

For signals with low source impedance and frequency, the $100\text{ k}\Omega$ input impedance on each input is large enough to prevent the inputs from loading the signal sources. The greater the source impedances and the higher the signal frequencies, the more you should take these factors into account.

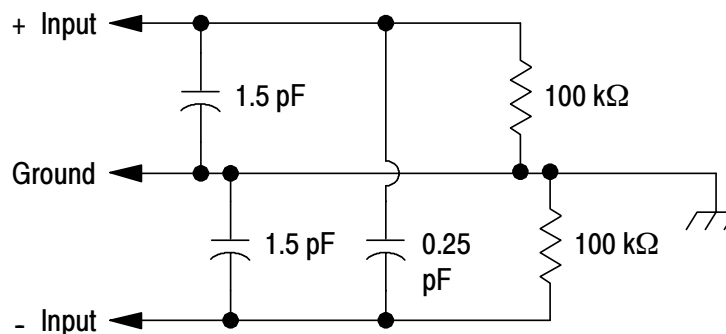

Figure 3: Typical probe input model

As the impedance of the signal source on an input increases, the more the probe loads the source and reduces the signal amplitude.

The frequency of the signal also affects signal measurement. As the frequency of the signal increases, the input impedance of the probe decreases. The lower the impedance of the probe relative to that of the source, the more the probe loads the circuit under test and reduces the signal amplitude. For a graph of frequency versus input impedance, refer to Figure 9 on page 26.

Common-Mode Rejection

The common-mode rejection ratio (CMRR) is the specified ability of a P6248 differential probe to reject signals that are common to both inputs. More precisely, CMRR is the ratio of the differential gain to the common-mode gain. The higher the ratio, the greater the ability to reject common-mode signals.

Common-mode rejection decreases as the input frequency increases. Figure 8 on page 26 is a plot of typical CMRR of the probe versus input frequency. For a more extended discussion of CMRR, see page 18.

Probing Techniques to Maximize CMRR

The common-mode rejection of the probe is highest when using the accessories shown in Figures 4 and 5. These accessories minimize the distance between the probe head and the signal source.

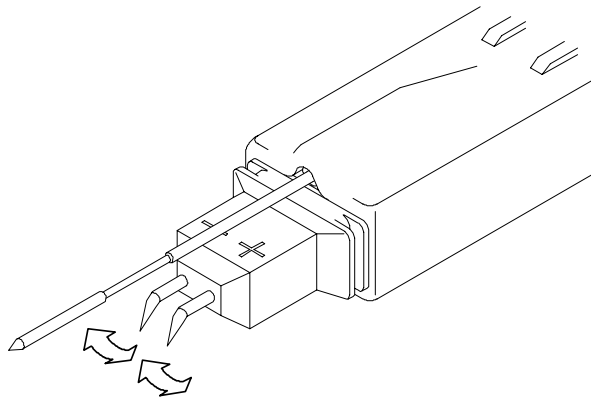

Figure 4: Using the input lead accessories to achieve high CMRR

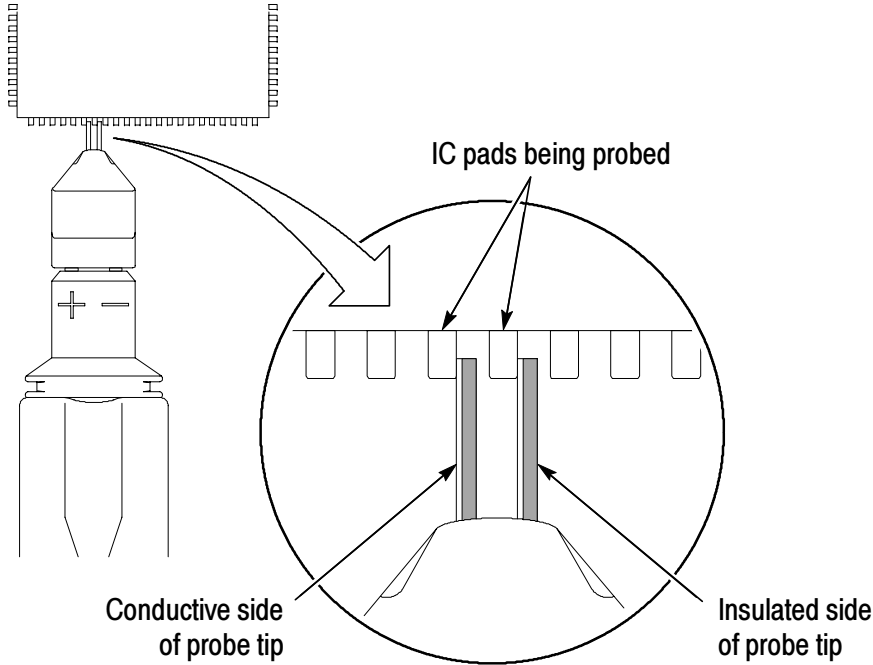

Figure 5: Using the TwinFoot adapter

Reference

This section contains important reference information about differential measurements and how to increase the accuracy of your measurements.

Problems with Single-Ended Measurements

While suitable in many applications, single-ended measurements can present problems in the following situations:

- When the signal is not referenced to earth ground
- When connecting or disconnecting the probe ground distorts the signal
- When connecting the signal reference to ground damages or upsets the circuit

Differential Measurements

Devices designed to make differential measurements avoid the problems posed by single-ended systems. These devices include a variety of differential probes, differential amplifiers, and isolators.

The differential amplifier (Figure 6) is at the heart of any device or system designed to make differential measurements. Ideally, the differential amplifier rejects any voltage that is common to the inputs and amplifies any difference between the inputs. Voltage that is common to both inputs is often referred to as the Common-Mode Voltage (V_{CM}) and voltage that is different as the Differential-Mode Voltage (V_{DM}).

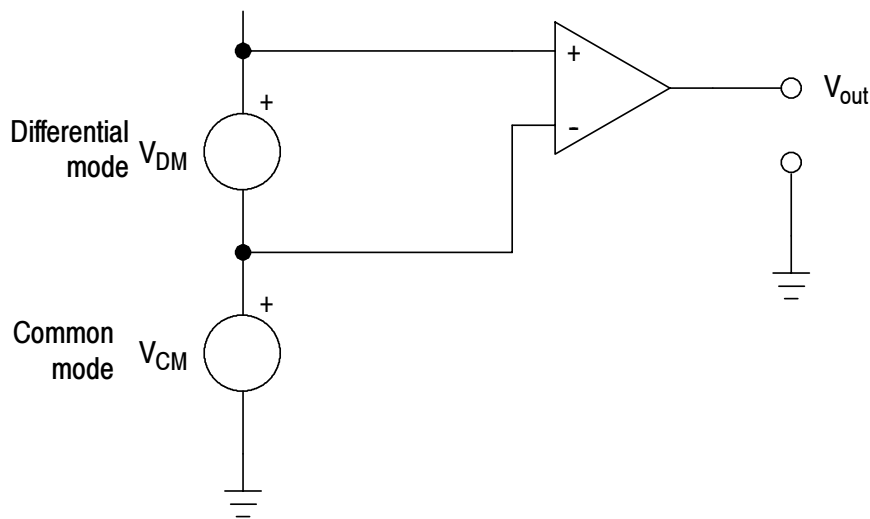

Figure 6: Simplified model of a differential amplifier

Common-Mode Rejection Ratio

In reality, differential amplifiers cannot reject all of the common-mode signal. The ability of a differential amplifier to reject the common-mode signal is expressed as the Common-Mode Rejection Ratio (CMRR). The CMRR is the differential-mode gain (A_{DM}) divided by the common-mode gain (A_{CM}). It is expressed either as a ratio or in dB.

$$CMRR = \frac{A_{DM}}{A_{CM}} \quad dB = 20 \log \frac{V_{DM}}{V_{CM}}$$

CMRR generally is highest (best) at DC and degrades with increasing frequency.

Assessing CMRR Error

Figure 8 on page 26 shows the CMRR of the P6248 differential probe. This derating chart assumes a common-mode signal that is sinusoidal.

A quick way to assess the magnitude of CMRR error when the common-mode signal is not sinusoidal is to connect both leads to the same point in the circuit. The oscilloscope will display only the common-mode component which is not fully rejected by the probe. While this technique may not give you entirely accurate measurements, it does allow you to determine if the magnitude of the common-mode error signal is significant.

Input Impedance Effects on CMRR

The lower the input impedance of the probe relative to the source impedance, the lower the CMRR. See Figure 9 on page 26. Significant differences in the source impedance driving the two inputs will also lower the CMRR.

Extending the Input Leads

At times it may be necessary to extend the probe inputs with wires or a probe tip adapter. When you do this, you should minimize the lead lengths to optimize common-mode rejection and twist the input leads together as shown in Figure 7.

Twisting the input leads together does increase capacitance that may degrade high-frequency performance. You should take into account any effects caused by the extended leads when you take a measurement.



CAUTION. *To avoid damaging the input connectors, do not insert anything larger than a 0.025-inch square pin into the inputs. Use the tip saver accessory to preserve the integrity of the input connectors.*

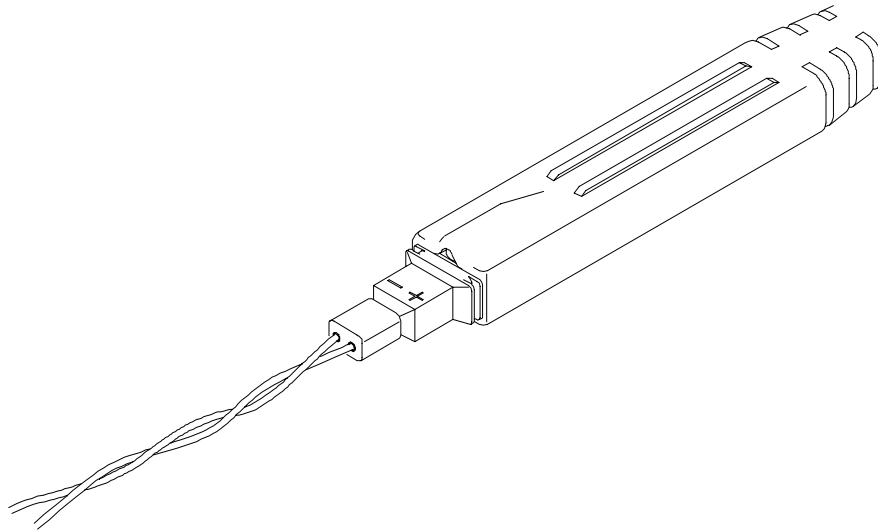

Figure 7: Twisting the Input Leads

Extending the Ground Lead

Extending the ground lead will have little, if any, affect on your measurements. In most circuits, the ground path from the differential source has sufficiently high impedance to damp out any ringing caused by lead inductance.

Extending the Probe Output

With the 1103 TEKPROBE power supply, it is possible to extend the output of the probe in order to connect the probe to other types of measurement instruments or simply to connect the probe to a signal source that is outside the reach of the probe.

Terminating the Probe

The probe must terminate into $50\ \Omega$ at the input of the measurement instrument. Use the 1103 TEKPROBE power supply to adapt the differential probe and set the input impedance of the measurement instrument to $50\ \Omega$. If the measurement instrument does not support $50\ \Omega$ input termination, connect a $50\ \Omega$ coaxial terminator on the input.

Effect of Extending the Output Cable

As the frequency of a signal increases, current flow concentrates at the outer edges of the conductor, effectively increasing the impedance. This effect is known as skin loss. The P6248 probe contains circuitry to compensate for skin loss.

The compensation provides flat response with the probe cable. Extending the length of the output cable increases the amount of skin loss beyond the range of compensation correction. Minimizing the length of cable extension reduces the attenuation.

In critical applications which require high amplitude accuracy, you should first characterize the response of the probe with the extension using a leveled signal source and power meter. Then, you can factor the characterization results into the measurement.

Using the Probe with Other Instruments

Besides the oscilloscope, it is possible to use the P6248 differential probe with other types of measurement instruments, such as spectrum analyzers, time interval analyzers, and network analyzers.

When using the differential probes with these instruments you must normalize the probe with the instrument before making a measurement.

Specifications

The specifications in Tables 4 through 7 apply to a P6248 probe installed on a Tektronix TDS 694C oscilloscope. When the probe is used with another oscilloscope, the oscilloscope must have an input impedance of 50 Ω . The probe must have a warm-up period of at least 20 minutes and be in an environment that does not exceed the limits described in Table 4. Specifications for the P6248 differential probe fall into three categories: warranted, typical, and nominal characteristics.

Warranted Characteristics

Warranted characteristics (Table 4) describe guaranteed performance within tolerance limits or certain type-tested requirements.

Warranted characteristics that have checks in the *Performance Verification* section of the service manual are marked with the ✓ symbol.

Table 4: Warranted electrical characteristics

Characteristic	Description
✓ DC attenuation accuracy	$\pm 2\%$ for input voltages as follows: ± 750 mV ($\div 1$) and ± 7.5 V ($\div 10$) $\pm 5\%$ for input voltages as follows: ± 850 mV ($\div 1$) and ± 8.5 V ($\div 10$)
Maximum non destructive input voltage	± 25 V _(DC + peak AC) between signal and common of the same channel.
✓ Differential signal range (DC coupled)	± 8.5 V at attenuation setting of $\div 10$ ± 850 mV at attenuation setting of $\div 1$
Common-mode signal range (DC coupled)	± 7 V

Table 4: Warranted electrical characteristics (Cont.)

Characteristic	Description
✓ Output offset voltage	± 10 mV (+ 20° C to + 30° C, + 68° F to + 86° F) ± 50 mV (0° C to + 60° C, + 32° F to + 122° F)
✓ Rise time (probe only)	< 265 ps
✓ Common-mode rejection ratio	45 dB at 1 MHz in ÷ 10 25 dB at 100 MHz in ÷ 10 20 dB at 500 MHz in ÷ 10 18 dB at 1 GHz in ÷ 10 60 dB at 1 MHz in ÷ 1 38 dB at 100 MHz in ÷ 1 35 dB at 500 MHz in ÷ 1 30 dB at 1 GHz in ÷ 1
Bandwidth (probe only)	DC to ≥ 1.5 GHz (- 3dB)
Temperature	Operating: 0 to + 50° C (+ 32 to + 122° F) 0 to + 60° C (+ 32 to + 140° F) ¹ (probe head) Nonoperating: - 55 to + 75° C (-131 to + 167° F) ¹
Humidity	Operating: 0-90% RH, tested at + 30 to + 50° C (+ 68 to + 122° F) Nonoperating: 0-90% RH, tested at + 30 to + 60° C (+ 68 to + 140° F)

¹ See warning that follows.



WARNING. To avoid a burn hazard at high ambient temperatures, do not touch the probe with bare hands at operating temperatures above + 50° C or at nonoperating temperatures above + 70° C. Allow sufficient time for the probe to cool before handling.

Typical Characteristics

Typical characteristics (Tables 5 and 6) describe typical but not guaranteed performance.

Table 5: Typical electrical characteristics

Characteristic	Description
Differential input resistance, DC coupled	$200\text{ k}\Omega \pm 2\%$
Common-mode input resistance, DC coupled	$100\text{ k}\Omega \pm 2\%$
Differential input capacitance	$< 1\text{ pF}$ at 1 MHz
Common-mode input capacitance	$< 2\text{ pF}$ at 1 MHz
Harmonic distortion	$\leq 1.5\%$ measured using $354\text{ mV}_{\text{RMS}}$ (or $1.0\text{ V}_{\text{P-P}}$) output at 100 MHz
Differential offset range	$\pm 700\text{ mV}$ ($\div 1$) $\pm 7\text{ V}$ ($\div 10$)
Common-mode rejection ratio	See Figure 8
Bandwidth (probe only)	DC to $\geq 1.7\text{ GHz}$ (-3dB) @ $\leq 27^\circ\text{ C}$ ($\div 1$) DC to $\geq 1.85\text{ GHz}$ (-3dB) @ $\leq 27^\circ\text{ C}$ ($\div 10$)
Random noise	$< 50\text{ nV}/\sqrt{\text{Hz}}$ at 100 MHz
Input impedance	See Figure 9
Pass band ripple	$\leq \pm 0.25\text{ dB}$ to the 3 dB bandwidth (deviation from a nominal slope)

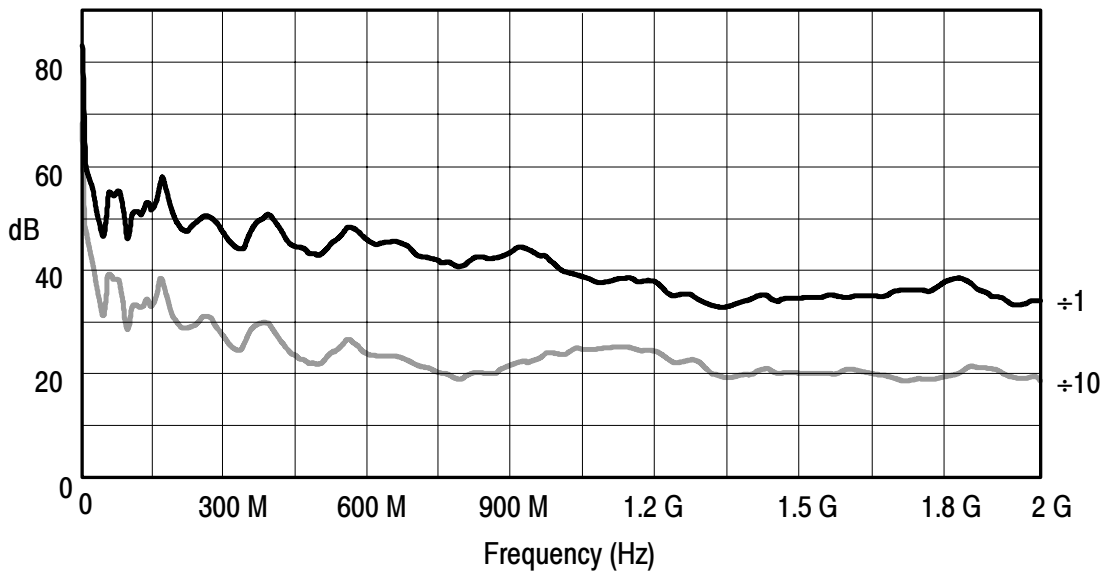

Figure 8: Typical Common-Mode Rejection Ratio ($\div 1$ and $\div 10$ attenuation)

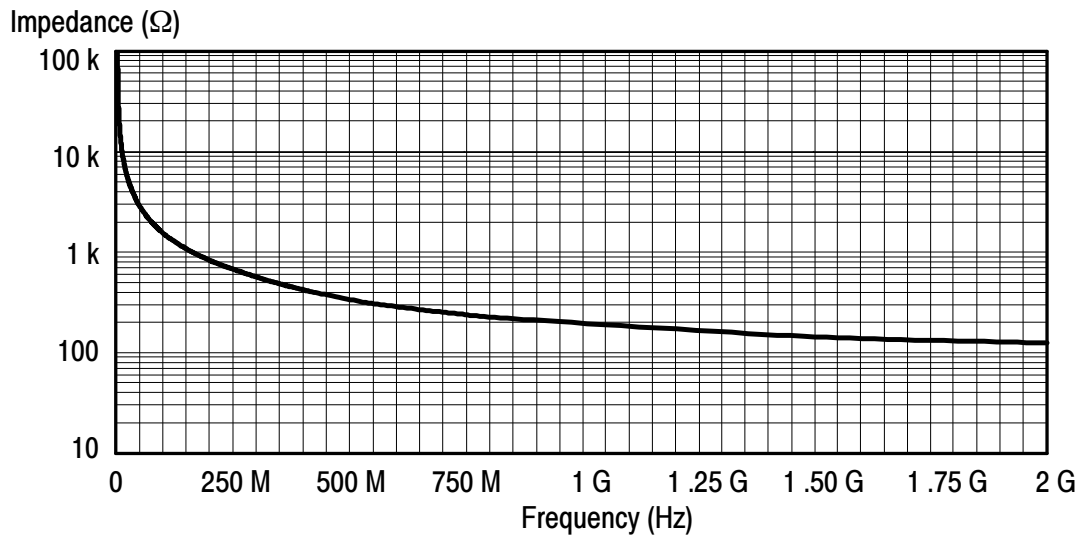

Figure 9: Typical differential input impedance versus frequency

The graph in Figure 9 represents simulation results of a first order model of the probe input.

Table 6: Typical mechanical characteristics

Dimensions, input connection	0.63 mm (0.025 in) square pin on 2.54 mm (0.100 in) centers
Dimensions, control box	107 mm × 41 mm × 26 mm (4.2 in × 1.6 in × 1.0 in)
Dimensions, probe head	78 mm × 12 mm × 9.3 mm (3.0 in × 0.47 in × 0.36 in)
Dimensions, output cable	1.2 m (47 in)
Unit weight (probe only)	160 g (5.4 oz)

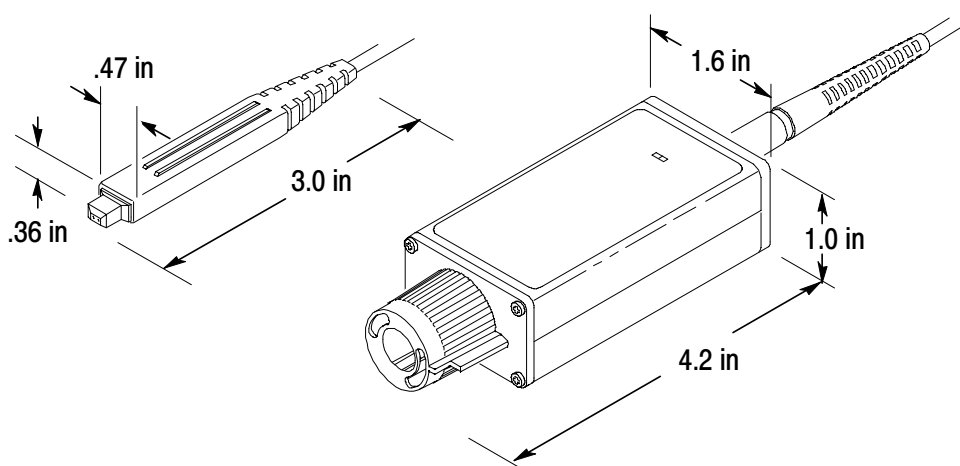

Figure 10: Probe head and compensation box dimensions

Nominal Characteristics

Nominal characteristics (Table 7) describe guaranteed traits, but the traits do not have tolerance limits.

Table 7: Nominal electrical characteristics

Input configuration	Differential (two inputs, + and -), with case ground
Output coupling	DC
Attenuation settings	÷ 1 and ÷ 10
Termination	Terminate output into 50 Ω

