



ABN 43 064 478 842

231 Osborne Avenue Clayton South, VIC 3169  
PO Box 1548, Clayton South, VIC 3169  
t 03 9265 7400 f 03 9558 0875  
freecall 1800 680 680  
www.tmgtestequipment.com.au

## Test & Measurement

- > sales
- > rentals
- > calibration
- > repair
- > disposal

## Complimentary Reference Material

This PDF has been made available as a complimentary service for you to assist in evaluating this model for your testing requirements.

TMG offers a wide range of test equipment solutions, from renting short to long term, buying refurbished and purchasing new. Financing options, such as Financial Rental, and Leasing are also available on application.

TMG will assist if you are unsure whether this model will suit your requirements.

Call TMG if you need to organise repair and/or calibrate your unit.

If you click on the "Click-to-Call" logo below, you can call us for FREE!

TMG Corporate Website

TMG Products Website



Click-to-Call  
TMG Now



Product Lifecycle Management System

### Disclaimer:

All trademarks appearing within this PDF are trademarks of their respective owners.



# Instruction Manual



## P7380SMA 8 GHz Differential Probe

**071-1392-01**

### **Warning**

The servicing instructions are for use by qualified personnel only. To avoid personal injury, do not perform any servicing unless you are qualified to do so. Refer to all safety summaries prior to performing service.

**[www.tektronix.com](http://www.tektronix.com)**

Copyright © Tektronix, Inc. All rights reserved.

Tektronix products are covered by U.S. and foreign patents, issued and pending. Information in this publication supercedes that in all previously published material. Specifications and price change privileges reserved.

Tektronix, Inc., P.O. Box 500, Beaverton, OR 97077

TEKTRONIX, TEK, and TekConnect are registered trademarks of Tektronix, Inc.

## WARRANTY

Tektronix warrants that the products that it manufactures and sells will be free from defects in materials and workmanship for a period of one (1) year from the date of shipment. If a product proves defective during this warranty period, Tektronix, at its option, either will repair the defective product without charge for parts and labor, or will provide a replacement in exchange for the defective product.

In order to obtain service under this warranty, Customer must notify Tektronix of the defect before the expiration of the warranty period and make suitable arrangements for the performance of service. Customer shall be responsible for packaging and shipping the defective product to the service center designated by Tektronix, with shipping charges prepaid. Tektronix shall pay for the return of the product to Customer if the shipment is to a location within the country in which the Tektronix service center is located. Customer shall be responsible for paying all shipping charges, duties, taxes, and any other charges for products returned to any other locations.

This warranty shall not apply to any defect, failure or damage caused by improper use or improper or inadequate maintenance and care. Tektronix shall not be obligated to furnish service under this warranty a) to repair damage resulting from attempts by personnel other than Tektronix representatives to install, repair or service the product; b) to repair damage resulting from improper use or connection to incompatible equipment; c) to repair any damage or malfunction caused by the use of non-Tektronix supplies; or d) to service a product that has been modified or integrated with other products when the effect of such modification or integration increases the time or difficulty of servicing the product.

**THIS WARRANTY IS GIVEN BY TEKTRONIX IN LIEU OF ANY OTHER WARRANTIES, EXPRESS OR IMPLIED. TEKTRONIX AND ITS VENDORS DISCLAIM ANY IMPLIED WARRANTIES OF MERCHANTABILITY OR FITNESS FOR A PARTICULAR PURPOSE. TEKTRONIX' RESPONSIBILITY TO REPAIR OR REPLACE DEFECTIVE PRODUCTS IS THE SOLE AND EXCLUSIVE REMEDY PROVIDED TO THE CUSTOMER FOR BREACH OF THIS WARRANTY. TEKTRONIX AND ITS VENDORS WILL NOT BE LIABLE FOR ANY INDIRECT, SPECIAL, INCIDENTAL, OR CONSEQUENTIAL DAMAGES IRRESPECTIVE OF WHETHER TEKTRONIX OR THE VENDOR HAS ADVANCE NOTICE OF THE POSSIBILITY OF SUCH DAMAGES.**



# Table of Contents

<b>Preface</b> .....	<b>vii</b>
Contacting Tektronix .....	viii
General Safety Summary .....	ix
Service Safety Summary .....	xi
<b>Getting Started</b> .....	<b>1</b>
Probe Controls and Connections .....	2
Standard Accessories .....	6
Optional Accessories .....	8
Options .....	10
TekConnect Interface .....	11
Probe Inputs .....	12
SMA Connectors .....	12
DC Termination Voltage Control Jacks .....	13
Probe Input Limitations .....	13
Probe Outputs .....	14
Termination Voltage Monitor Jacks .....	14
Auxiliary Output SMA Connector .....	14
Functional Check .....	15
Power-on Self Test .....	16
Signal and Termination Voltage Monitor Check .....	17
Aux Output Check .....	20
DC Termination Voltage Zero Check .....	22
Probe Calibration .....	24
Using the Probe .....	26
Auto Mode .....	26
External Mode .....	27
Internal Mode .....	28
Auxiliary Output .....	29
Using the Probe With a Sampling Oscilloscope .....	30
P6150 Probe Tips .....	32
<b>Operating Basics</b> .....	<b>33</b>
Differential Measurements for Serial Data Compliance Testing .....	33
Differential Signalling .....	33
Pseudo-Differential Measurements .....	34
Differential Probe Measurements .....	35
Common-Mode Rejection Ratio .....	36

## Table of Contents

---

Probe Block Diagram (Simplified) .....	37
Matched-Delay Cables .....	37
Input Termination Network .....	38
Internal Probe Amplifier .....	40
Termination Voltage Control .....	44
Auto Mode .....	45
Int Mode .....	45
Ext Mode .....	45
Overdrive Error .....	47
Differential and Single-Ended Signal Measurement .....	48
Differential Measurement Topology .....	48
Differential Dynamic Range .....	49
Single-Ended Measurement Topology .....	50
Single-Ended Measurement Procedure .....	54
Single-Ended Dynamic Range .....	55
Extending the Input Connections .....	56
Checking Cable Skew .....	57
Adjusting Cable Skew .....	58
Deskewing Probes .....	60
<b>Reference</b> .....	<b>63</b>
Serial Bus Standards .....	63
InfiniBand .....	64

<b>Appendix A: Specifications</b> .....	<b>65</b>
Warranted Characteristics .....	65
Typical Characteristics .....	66
Nominal Characteristics .....	71
Mechanical Characteristics .....	71
<b>Appendix B: Performance Verification</b> .....	<b>73</b>
Equipment Required .....	73
Special Adapters Required .....	75
TekConnect-to-SMA Adapter .....	75
Equipment Setup .....	76
Input Resistance .....	77
Termination Voltage Accuracy .....	78
Ext Mode .....	78
Int Mode .....	79
Auto Mode .....	80
Output Offset Zero .....	82
DC Gain Accuracy .....	83
Gain Check at 2.5X Attenuation .....	83
Gain Check at 12.5X Attenuation .....	85
Rise Time .....	85
Rise Time Check at 12.5X Attenuation .....	85
Rise Time Check at 2.5X Attenuation .....	89
<b>Appendix C: User Service</b> .....	<b>91</b>
Probe/Adapter/Oscilloscope Compatibility .....	91
Check Compatibility .....	91
Error Conditions .....	92
Inspection and Cleaning .....	93
Replacement Parts .....	93
Preparation for Shipment .....	94



## List of Tables

Table 1: P7380SMA features .....	2
Table 2: P7380SMA standard accessories .....	6
Table 3: Optional accessories .....	8
Table 4: Equipment required for functional checks .....	15
Table 5: Common-mode voltage and current table .....	39
Table 6: Differential to single-ended conversion table .....	55
Table 7: Serial bus standards with dynamic range requirements .....	63
Table 8: Warranted electrical characteristics .....	65
Table 9: Typical electrical characteristics .....	66
Table 10: Nominal electrical characteristics .....	71
Table 11: Typical mechanical characteristics .....	71
Table 12: Equipment required for performance verification ..	73
Table 13: P7380SMA probe compatibility issues .....	91
Table 14: LED error conditions .....	92

## List of Figures

Figure 1: P7380SMA differential probe	1
Figure 2: Connecting and disconnecting the probe	11
Figure 3: Probe signal input connections	12
Figure 4: Signal check setup	17
Figure 5: Aux output check test setup	20
Figure 6: DC termination voltage check setup	22
Figure 7: Probe calibration setup	25
Figure 8: Using Auto Termination Voltage Control Mode	26
Figure 9: Using External Termination Voltage Control Mode	27
Figure 10: Using Internal Termination Voltage Control Mode	28
Figure 11: Viewing the Aux Out signal on a spectrum analyzer	29
Figure 12: Using the probe with an 80A03 Interface and an 80A05 Module to view eye diagrams on a TDS8000 Series sampling oscilloscope	31
Figure 13: P6150 probe tips	32
Figure 14: Simplified model of a differential amplifier	36
Figure 15: Input termination network	37
Figure 16: Probe maximum input limits	42
Figure 17: Differential and Common-Mode operating ranges	43
Figure 18: Termination voltage network drive	44
Figure 19: Overdrive Error indicator	47
Figure 20: Differential measurement topology	48
Figure 21: 50 ohm termination on (-) input	51
Figure 22: Shorting termination on (-) input	52
Figure 23: Open (-) input	53
Figure 24: Checking skew between inputs	57
Figure 25: Using the phase adjuster	59
Figure 26: Deskewing two P7380SMA probes	61
Figure 27: InfiniBand signals	64
Figure 28: Typical CMRR plot	68
Figure 29: Typical differential input return loss	69
Figure 30: Typical differential-mode bandwidth	69
Figure 31: Typical eye pattern from an InfiniBand signal	70
Figure 32: Typical differential step response	70
Figure 33: Probe dimensions	72
Figure 34: TekConnect-to-SMA Adapter	75
Figure 35: Preliminary test setup	76

Figure 36: Checking differential mode input resistance . . . . .	77
Figure 37: Termination Voltage Accuracy, Ext mode setup . . .	78
Figure 38: Termination Voltage Accuracy, Auto mode setup . .	80
Figure 39: Setup for the output offset zero test . . . . .	82
Figure 40: DC Gain Accuracy setup . . . . .	83
Figure 41: Reverse the power supply polarity on the probe inputs . . . . .	84
Figure 42: Test system rise time setup . . . . .	86
Figure 43: Setting the TDR parameters . . . . .	87
Figure 44: Test system rise time setup with probe . . . . .	88



# Preface

This is the Instruction Manual for the P7380SMA differential probe. This manual provides operating information, specifications, and performance verification procedures for the probe.

## Contacting Tektronix

<b>Phone</b>	1-800-833-9200*
<b>Address</b>	Tektronix, Inc. Department or name (if known) 14200 SW Karl Braun Drive P.O. Box 500 Beaverton, OR 97077 USA
<b>Web site</b>	<a href="http://www.tektronix.com">www.tektronix.com</a>
<b>Sales support</b>	1-800-833-9200, select option 1*
<b>Service support</b>	1-800-833-9200, select option 2*
<b>Technical support</b>	<a href="http://www.tektronix.com/support">www.tektronix.com/support</a> 1-800-833-9200, select option 3* 6:00 a.m. - 5:00 p.m. Pacific Standard Time

---

\* **This phone number is toll free in North America. After office hours, please leave a voice mail message. Outside North America, contact a Tektronix sales office or distributor; see the Tektronix web site for a list of offices.**

# General Safety Summary

Review the following safety precautions to avoid injury and prevent damage to this product or any products connected to it. To avoid potential hazards, use this product only as specified.

## To Avoid Fire or Personal Injury

**Connect and Disconnect Properly.** Connect the probe output to the measurement instrument before connecting the probe to the circuit under test. Disconnect the probe input from the circuit under test before disconnecting the probe from the measurement instrument.

**Observe All Terminal Ratings.** To avoid fire or shock hazard, observe all ratings and markings on the product. Consult the product manual for further ratings information before making connections to the product.

The common terminal is at ground potential. Do not connect the common terminal to elevated voltages.

**Do Not Operate Without Covers.** Do not operate this product with covers or panels removed.

**Do Not Operate With Suspected Failures.** If you suspect there is damage to this product, have it inspected by qualified service personnel.

**Do Not Operate in Wet/Damp Conditions.**

**Do Not Operate in an Explosive Atmosphere.**

**Keep Product Surfaces Clean and Dry.**

## Safety Terms and Symbols

**Terms in This Manual.** These terms may appear in this manual:



---

**WARNING.** *Warning statements identify conditions or practices that could result in injury or loss of life.*

---



---

**CAUTION.** *Caution statements identify conditions or practices that could result in damage to this product or other property.*

---

**Terms on the Product.** These terms may appear on the product:

DANGER indicates an injury hazard immediately accessible as you read the marking.

WARNING indicates an injury hazard not immediately accessible as you read the marking.

CAUTION indicates a hazard to property including the product.

**Symbols on the Product.** These symbols may appear on the product:



CAUTION  
Refer to Manual



## Service Safety Summary

Only qualified personnel should perform service procedures. Read this *Service Safety Summary* and the *General Safety Summary* before performing any service procedures.

**Do Not Service Alone.** Do not perform internal service or adjustments of this product unless another person capable of rendering first aid and resuscitation is present.

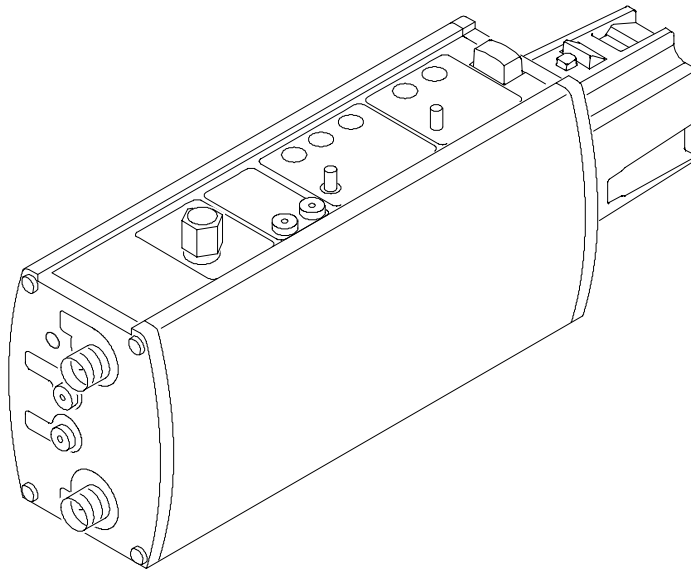




# Getting Started

The P7380SMA is an 8 GHz, active differential probe designed for Serial Data Analysis (SDA) compliance testing and other applications that use differential serial busses in a 50  $\Omega$  signaling environment. The SMA input connectors each terminate with an internal 50  $\Omega$  resistor. The internal 50  $\Omega$  resistors are not directly grounded, but are driven by a buffer amplifier to a common-mode DC termination voltage. The termination voltage range allows the termination voltage to be set to any value within the specified common mode voltage range of the input signal.

The DC termination voltage can be supplied either externally or internally, including an automatic mode that sets the value of the termination voltage to match the input signal DC common-mode voltage. The P7380SMA probe has two selectable attenuator settings that provide a tradeoff between dynamic range and noise. The P7380SMA probe has been optimized for a clean pulse response for accurate SDA compliance testing.



**Figure 1: P7380SMA differential probe**

The probe incorporates the high-performance TekConnect interface to communicate with the host instrument. In addition to the acquired signal that is routed through the TekConnect interface, the probe also provides a full-bandwidth, inverted-phase auxiliary output. The auxiliary output can be used for additional signal analysis by connecting it to a spectrum analyzer, network analyzer, or clock recovery unit.

The probe is shipped with 50  $\Omega$  termination caps connected to the three SMA input and output connectors. When you are not using the probe, leave the termination caps connected to protect the circuitry from damage.

Always leave the Auxiliary output connector terminated when not in use, to provide the best signal fidelity for the main probe output.

## Probe Controls and Connections

Table 1 briefly outlines the controls and connections of the P7380SMA differential probe. Additional information can be found later in *Getting Started* and the following *Operating Basics* sections.

**Table 1: P7380SMA features**

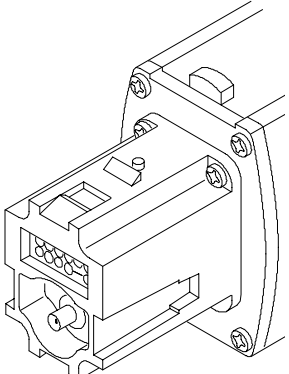
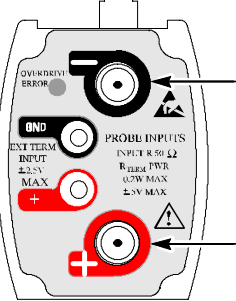
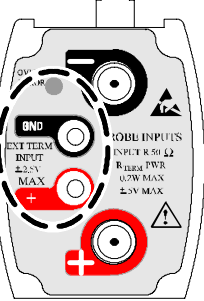
Control/Connection	Description
	<p><b>TekConnect interface.</b> The TekConnect interface provides a communication path between the probe and the oscilloscope. Contact pins provide power, signal, offset, and probe characteristic data transfer.</p> <p>The probe snaps into the oscilloscope when fully engaged. To remove, grasp the compensation box, press the latch button, and pull the probe out.</p> <p>For more information, see page 11.</p>

Table 1: P7380SMA features (Cont.)

Control/Connection	Description
	<p><b>Input signal connections.</b> The SMA terminals provide shielded, low-noise connections to your circuit. Differential or single-ended signals are buffered by the internal probe amplifier and are sent through the TekConnect interface to the oscilloscope.</p> <p>See <i>Probe Inputs</i> on page 12 for more information.</p>
	<p><b>External DC termination control voltage connections.</b> The red and black 0.080 in jacks on the end of the probe provide a means for controlling the DC termination voltage with an external DC power supply.</p> <p>You should use the Banana-to-0.080 in plug adapter cables included with the probe when connecting external control voltages to these terminals.</p> <p>The Overdrive Error LED glows continually red when the termination voltage driver current exceeds its linear range. In general, this will occur when the termination voltage differs from the common-mode voltage by about 2.0 volts for zero-ohm source impedances and about 4.0 volts for 50 ohm source impedances.</p> <p>The Overdrive Error LED flashes when the termination voltage in Auto Mode or EXT Mode exceeds the specified <math>\pm 2.5</math> volt range by about 10%.</p> <p>The Overdrive Error LED clears when the range violation signal is removed.</p> <p>For more information, see pages 13 and 47.</p>

**Table 1: P7380SMA features (Cont.)**

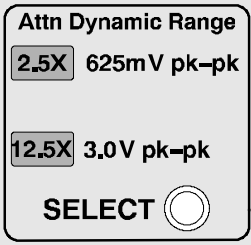
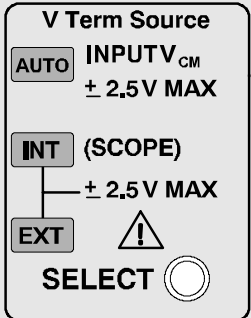
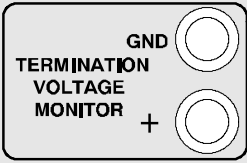
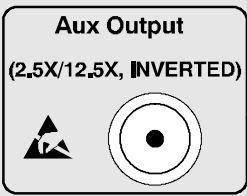
Control/Connection	Description
 <p>The image shows a control panel titled "Attn Dynamic Range". It has two buttons: "2.5X" and "12.5X". Next to "2.5X" is the text "625mV pk-pk" and next to "12.5X" is "3.0V pk-pk". Below these buttons is a "SELECT" button with a circular indicator.</p>	<p><b>Attenuation/Dynamic Range Select and indicators.</b> The Atten Dynamic Range Select button allows you to select between 2.5X and 12.5X probe attenuation settings. Note that the maximum linear dynamic range for each attenuator setting is specified as a differential peak-to-peak value.</p> <p>The two indicator LEDs light briefly when the probe is powered on, and then the 12.5X LED lights to indicate the 12.5X attenuation is selected.<sup>1</sup></p> <p>If both LEDs flash, an internal probe diagnostic fault exists. Disconnect and reconnect the probe to restart the power-on diagnostic sequence. If the LEDs continue to flash, the probe is defective, and must be returned to Tektronix for repair.</p>
 <p>The image shows a control panel titled "V Term Source". It has three buttons: "AUTO", "INT (SCOPE)", and "EXT". Next to "AUTO" is the text "INPUT V<sub>CM</sub> ± 2.5V MAX". Next to "INT (SCOPE)" is "± 2.5V MAX". Next to "EXT" is a warning triangle icon. Below these buttons is a "SELECT" button with a circular indicator.</p>	<p><b>Termination Voltage Control Mode Select and indicators.</b> The V Term Source Select button allows you to select between three termination voltage control modes—Auto, Internal, and External. The three indicator LEDs light briefly when the probe is powered on, and then the Auto LED lights.<sup>1</sup></p> <p>The probe initially sets to Auto mode; press the SELECT button to choose another mode. The Auto Mode LED also flashes when the probe signal inputs are AC-coupled or open-circuit. When this happens, the termination voltage is set to 0.0 V.</p> <p>In Auto mode, the input signal DC common mode voltage is measured and the DC termination voltage is automatically set to equal that voltage. This is the default mode setting when the probe is powered on.</p> <p>In Internal mode, the DC termination voltage is set with user interface controls that are available on TekConnect-interface oscilloscopes that support this mode. If your oscilloscope does not support this mode, the termination voltage defaults to 0 volts.</p> <p>In External mode, the DC termination voltage is controlled indirectly with an external DC power supply connected to the 0.080 in pin jacks on the probe face plate. If these control voltage inputs are left open, the termination voltage defaults to 0 volts.</p>

Table 1: P7380SMA features (Cont.)

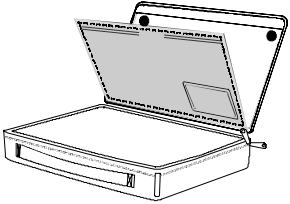


Control/Connection	Description
	<p><b>Termination Voltage Monitor jacks.</b> These red and black jacks provide a means for connecting a DMM to the probe to monitor the DC termination voltage. For example, this can be used in Auto mode to indirectly measure the DC common-mode input voltage.</p>
 <p><b>Tektronix</b>  <b>P7380 SMA</b>        8 GHz (Typical)  <math>t_r &lt; 55\text{ps}</math>        Differential Signal        Acquisition System</p>	<p><b>Auxiliary Output connector.</b> This SMA connector provides a full-bandwidth, attenuated, inverted sample of the input signal. Use this auxiliary signal to trigger your TDS/CSA 8000 series sampling oscilloscope, or as an input to a spectrum analyzer or network analyzer to measure the frequency domain response of the input signal.</p> <p>When you are not using this connector, leave the termination cap connected to protect the SMA output connector from damage and to ensure maximum signal fidelity of the main probe output signal to the oscilloscope.</p>

- <sup>1</sup> **If the Attenuation and Termination Source LEDs do not light as described, the host oscilloscope may have stored different attenuation and termination source settings from a previous session. Use the SELECT buttons on the probe to change the settings if necessary.**

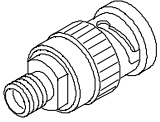
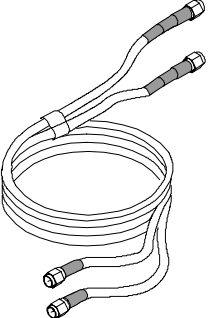
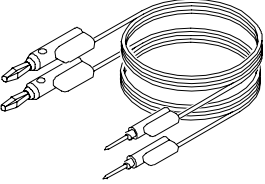
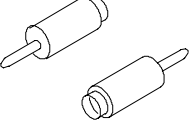
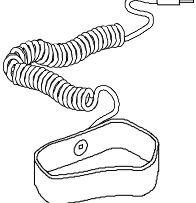
## Standard Accessories

Table 2 shows the standard accessories included with the P7380SMA differential probe. To order replacements, use the Tektronix part number listed with each accessory.

**Table 2: P7380SMA standard accessories**

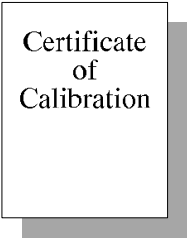
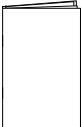
Accessory	Description
	<p><b>Carrying case with inserts.</b> The soft-sided nylon carrying case has several compartments to hold the probe, accessories, and related documentation. Use the case to store or transport the probe.</p> <p>Tektronix part number 016-1952-XX</p>
	<p><b>Male SMA 50 <math>\Omega</math> termination (3 ea).</b> The probe is shipped with these terminations connected to the probe SMA inputs and the Auxiliary Output connector. Protect the probe circuitry by connecting the terminations to these connectors when the probe is not in use.</p> <p>When making single-ended measurements in a 50 <math>\Omega</math> environment, one of these terminations may be used on the unused input.</p> <p>Only remove the 50 <math>\Omega</math> termination from the Auxiliary Output connector when you connect the Auxiliary Output to another measurement instrument, such as a network analyzer. Otherwise, leave the termination connected to the probe.</p> <p>Tektronix part number: 015-1022-XX (package of 1)</p>
	<p><b>Male SMA short-circuit.</b> Use this adapter when performing a functional check on the probe.</p> <p>The SMA short-circuit may also be used to terminate an unused input in one possible single-ended measurement topology. See page 52 for more information.</p> <p>Tektronix part number: 015-1020-XX</p>

**Table 2: P7380SMA standard accessories (Cont.)**

Accessory	Description
	<p><b>SMA Female-to-BNC Male adapter.</b> Use the adapter to connect the probe SMA inputs to BNC connections, such as the BNC calibration output connector on your oscilloscope.</p> <p>Tektronix part number: 015-0572-XX</p>
	<p><b>Dual SMA cables.</b> These 38 in cables are bound together and have factory-calibrated integral phase adjusters to limit cable-to-cable skew to less than 1 ps. (See page 8 for external, user-adjustable phase adjusters.) The cables are color-coded at each end for easy identification, and provide matched signal paths from your circuit to the probe to ensure accurate differential signal measurements. The P7380SMA differential probe includes built-in cable loss compensation when used with the cable assembly.</p> <p>Note: To make DUT connections easier, connect the phase-adjuster ends of the cables to the probe inputs.</p> <p>Tektronix part number: 174-4944-XX</p>
	<p><b>0.080 in Pin-to-Banana plug adapter cables.</b> Use these cables in external mode to control the DC termination voltage, using an external power supply to set the value.</p> <p>Tektronix part number: 012-1674-XX (red), 012-1675-XX (black)</p>
	<p><b>0.040 in-to-0.080 in Pin jack adapters.</b> Use two pin jack adapters to connect the 0.040 in Termination Voltage Monitor jacks to the 0.080 in pin-to-banana plug adapter cables. Connect the banana plug ends of the cables to a DMM to measure the termination voltage.</p> <p>Tektronix part number: 012-1676-XX (package of 1)</p>
	<p><b>Antistatic wrist strap.</b> When using the probe, always work at an antistatic work station and wear the antistatic wrist strap.</p> <p>Tektronix part number: 006-3415-XX</p>



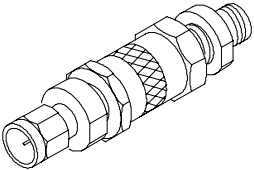
**Table 2: P7380SMA standard accessories (Cont.)**

Accessory	Description
	<p><b>Calibration certificate.</b> A certificate of traceable calibration is provided with every instrument shipped.</p>
	<p><b>Instruction Manual.</b> Provides instructions for operating and maintaining the P7380SMA differential probe.</p> <p>Tektronix part number: 071-1392-XX</p>

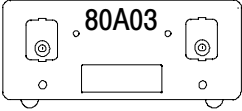
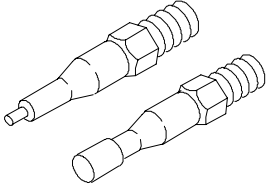
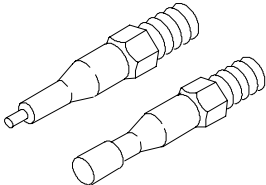
## Optional Accessories

Table 3 shows the optional accessories that you can order for the P7380SMA differential probe.

**Table 3: Optional accessories**

Accessory	Description
	<p><b>Phase adjuster.</b> Use two phase adjusters if you need to bring the skew between inputs to 1 ps or less because of skew in the device under test differential signal path. See <i>Adjusting Cable Skew</i> on page 58 for instructions. The phase adjuster has a 25 ps adjustment range.</p> <p>The matched-delay SMA cables that come with your probe have a <math>\leq 1</math> ps skew at the cable ends.</p> <p>Tektronix part number: 015-0708-XX (package of 1)</p>

**Table 3: Optional accessories (Cont.)**

Accessory	Description
 <p>The image shows a rectangular module with two SMA connectors on the front panel and a central slot for an 80E0X module. The label '80A03' is visible on the top left.</p>	<p><b>80A03.</b> The 80A03 TekConnect Probe Interface Module is an adapter that allows you to use TekConnect probes with CSA8000 and TDS8000 Series sampling oscilloscopes and 80E0X sampling modules.</p> <p>The interface is comprised of an enclosure that houses a compartment for one 80E0X electrical sampling module and two TekConnect probe inputs. The interface routes the probe signal outputs through SMA connectors on the front panel. Semi-rigid SMA cables link the probe outputs to the 80E0X module inputs.</p> <p>The 80A03 Interface Module is required to complete a performance verification of the probe.</p>
 <p>The image shows two probe tips: one with a wide blade and one with a standard tip, both attached to SMA connectors.</p>	<p><b>P6150 Probe.</b> Use the P6150 probe for checking discrete test points in your circuit. An assortment of circuit and grounding attachments are included to help you maintain high signal integrity.</p> <p>For best high-frequency performance, the wide-blade ground accessory should be used with the probe tips and cut as short as possible to connect to a ground point near the probed signal. However, to prevent delay mismatches, do not use the cable included with the P6150 probe. Instead, attach the tips to the ends of the matched SMA cables that are included with the P7380SMA probe.</p> <p>Note: The P6150 probe includes (one) 1X- and (two) 10X-attenuation probe tips. If you need more tips, see <i>P6150 Attenuation Tips</i> below for ordering information.</p>
 <p>The image shows two probe tips: one with a wide blade and one with a standard tip, both attached to SMA connectors.</p>	<p><b>P6150 Attenuator Tips.</b> These tips attach to the ends of the matched SMA cables that are included with the P7380SMA probe, and are available in 1X and 10X attenuation values.</p> <p>Tektronix part number: 206-0398-00 (1X Attenuation, 1 each)</p> <p>Tektronix part number: 206-0399-03 (10X Attenuation, pkg of 2)</p>

## Options

These options are available when ordering the P7380SMA probe:

- Option D1-Calibration Data Report
- Option D3-Calibration Data Report, 3 years (with Option C3)
- Option C3-Calibration Service 3 years
- Option D5-Calibration Data Report, 5 years (with Option C5)
- Option C5-Calibration Service 5 years
- Option R3-Repair Service 3 years
- Option R5-Repair Service 5 years

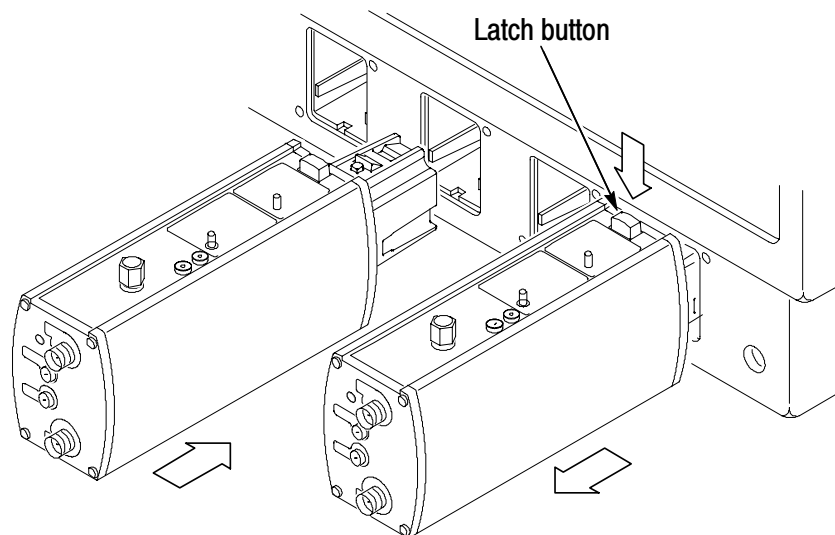
## TekConnect Interface

The P7380SMA probe is powered through a TekConnect interface between the probe compensation box and the host instrument. The TekConnect interface provides a communication path through contact pins on the host instrument. Power, signal, offset, and probe characteristic data transfer through the interface.

When the probe is connected, the host instrument reads EEPROM information from the probe, identifying the device and allowing the appropriate power supplies to be turned on. The preamp inputs on the host instrument are ESD protected by remaining grounded until a valid TekConnect device is detected.

The TekConnect interface features a spring-loaded latch that provides audible and tactile confirmation that a reliable connection has been made to the host instrument. Slide the probe into the TekConnect receptacle on the host instrument. The probe snaps into the receptacle when fully engaged. See Figure 2.

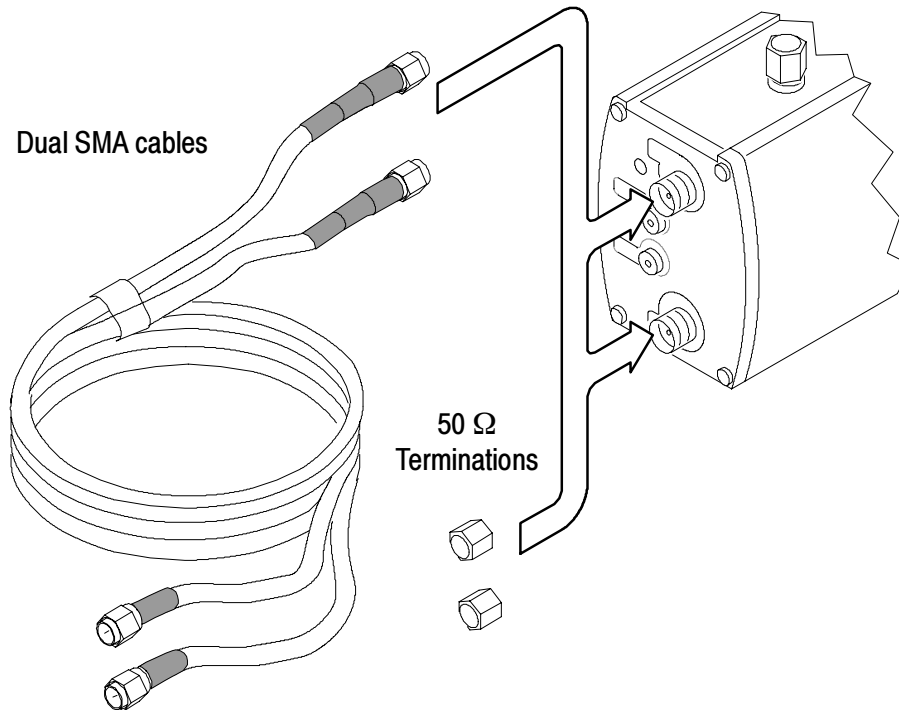
To release the probe from the host instrument, grasp the compensation box, press the latch button, and pull out the probe.



**Figure 2: Connecting and disconnecting the probe**

## Probe Inputs

The P7380SMA probe has two pairs of input connectors—one for SMA signals and one for external DC termination voltages. Options for the SMA input connections are shown in Figure 3.



**Figure 3: Probe signal input connections**

### SMA Connectors

The SMA connectors provide a signal path through the internal 50  $\Omega$  termination network and differential probe buffer amplifier to the oscilloscope.

Use the matched-delay SMA cables that are supplied with the probe to connect the probe to your circuit.

Leave the 50  $\Omega$  terminations on the unused inputs.

## DC Termination Voltage Control Jacks

Jacks are provided on the probe faceplate for external control of the DC termination voltage, when the Vterm Source Select is set to EXT mode. The jacks accept the 0.080 in pin-to-banana cables included with your probe, to connect to an external power supply with banana plug outputs.

The red terminal is the DC control voltage input to a buffer amplifier that drives the center-tap (common-mode node) of the internal 50  $\Omega$  termination network. The 100 K $\Omega$  resistance to ground at the buffer amplifier input gives a 0.00V termination voltage in EXT mode with the inputs open. The black terminal is connected to system ground.

The normal termination voltage range is  $\pm 2.5$  volts. The buffer amplifier input is diode-protected to  $\pm 15$  volts, but the Overdrive Error LED will flash when the EXT termination voltage is driven about 10% beyond the specified  $\pm 2.5$  V range. See *Overdrive Error* on page 47 for more information.

## Probe Input Limitations

Although the allowable input DC common mode ( $V_{CM}$ ) range and the termination voltage ( $V_T$ ) range are both  $\pm 2.5$  V, there are additional limitations on the voltage difference between  $V_{CM}$  and  $V_T$  that you must consider, to avoid non-linear operation.

Because of the low resistance 50  $\Omega$  termination network, relatively large currents can flow, depending on the input signal source impedance and the  $V_{CM}$  and  $V_T$  voltage difference. Since the amplifier that drives the  $V_T$  voltage node between the two 50  $\Omega$  termination resistors (see Figure 15 on page 37) has a current limit of about  $\pm 82$  mA for linear operation, this limits the allowable voltage difference between  $V_{CM}$  and  $V_T$ .

As a general guideline, the voltage difference between  $V_{CM}$  and  $V_T$  should be limited to about 2 V for zero-ohm source impedances and about 4 V for 50-ohm source impedances. More exact calculations of the termination network and input load currents can be made using the equations in Table 5 on page 39.

## Probe Outputs

The probe provides terminals for monitoring the DC termination voltage of the measured signal. Also, the inverted polarity of the output signal that is passed through the TekConnect interface to the oscilloscope is brought out to an SMA connector. These connections are located on the top panel of the probe.

### Termination Voltage Monitor Jacks

Two 0.040 in jacks allow you to monitor the termination voltage of the signal under test, using a DMM and a pair of standard DMM test leads. The output impedance of the termination voltage monitor (+) output is about 1K ohm. The other output of the termination voltage monitor is connected to signal ground.

### Auxiliary Output SMA Connector

This SMA connector provides an attenuated, inverted sample of the signal under test. The attenuation factor of the output signal matches the selected attenuation factor of the probe. This signal can be used to trigger your TDS/CSA 8000 series sampling oscilloscope, or as an input to a spectrum- or network analyzer.

## Functional Check

Before using your probe, you should perform a functional check. A basic functional check comprises the following:

- A power-on self test that verifies LED operation
- An input signal amplitude and termination voltage monitor output test

If you want to check the remaining probe functions, complete the following checks:

- Auxiliary output amplitude and polarity
- Termination voltage zero check

The equipment required for the functional checks is listed in Table 4.

**Table 4: Equipment required for functional checks**

Item description	Performance requirement	Recommended example <sup>1</sup>
Oscilloscope	TekConnect interface	Tektronix TDS6604 or TDS7704
DMM	1.0 mV resolution	Fluke 87 or equivalent
Coaxial cable	Dual SMA, matched-delay	174-4944-00 <sup>2</sup>
Test leads	0.080 in pin-to-Banana plug ends, one each color	012-1674-00 (red) <sup>2</sup> 012-1675-00 (black) <sup>2</sup>
Adapters (3)	SMA 50 $\Omega$ termination	015-1022-01 <sup>3</sup>
Adapter	SMA short-circuit	015-1020-00 <sup>3</sup>
Attenuator	SMA or BNC, 50 $\Omega$ , 5X	015-1002-01 (SMA) 011-0060-03 (BNC)
Adapter	TekConnect-to-SMA	Tektronix TCA-SMA
Adapter	BNC Male-to-SMA Female	015-0572-00 <sup>3</sup>
Adapters (2)	0.040 in-to-0.080 in Pin jack	012-1676-XX <sup>3</sup>

<sup>1</sup> **Nine-digit part numbers (xxx-xxxx-xx) are Tektronix part numbers.**

<sup>2</sup> **Standard accessories included with the probe.**



### Power-on Self Test

When the probe is powered on, an internal diagnostic check is performed to verify basic probe functionality. The probe goes through a communications check with the host instrument, and cycles the status LEDs on the probe.

For a visual check of the probe LED functionality, connect the probe to the oscilloscope channel you wish to use, and observe the probe status LEDs for the following:

- All six LEDs light briefly—five on the top panel and the Overdrive Error LED on the front panel.
- Two LEDs light again and remain lit:
  - 12.5X Attenuation
  - AUTO Voltage Termination Source

The other LEDs remain unlit.

---

**NOTE.** *If the Attenuation and Termination Source LEDs do not light as described, the oscilloscope may have stored different attenuation and termination source settings from a previous session. Use the SELECT buttons on the probe to toggle the LEDs to the 12.5X and AUTO settings.*

*The Auto Mode LED will flash if the probe inputs are open or AC-coupled.*

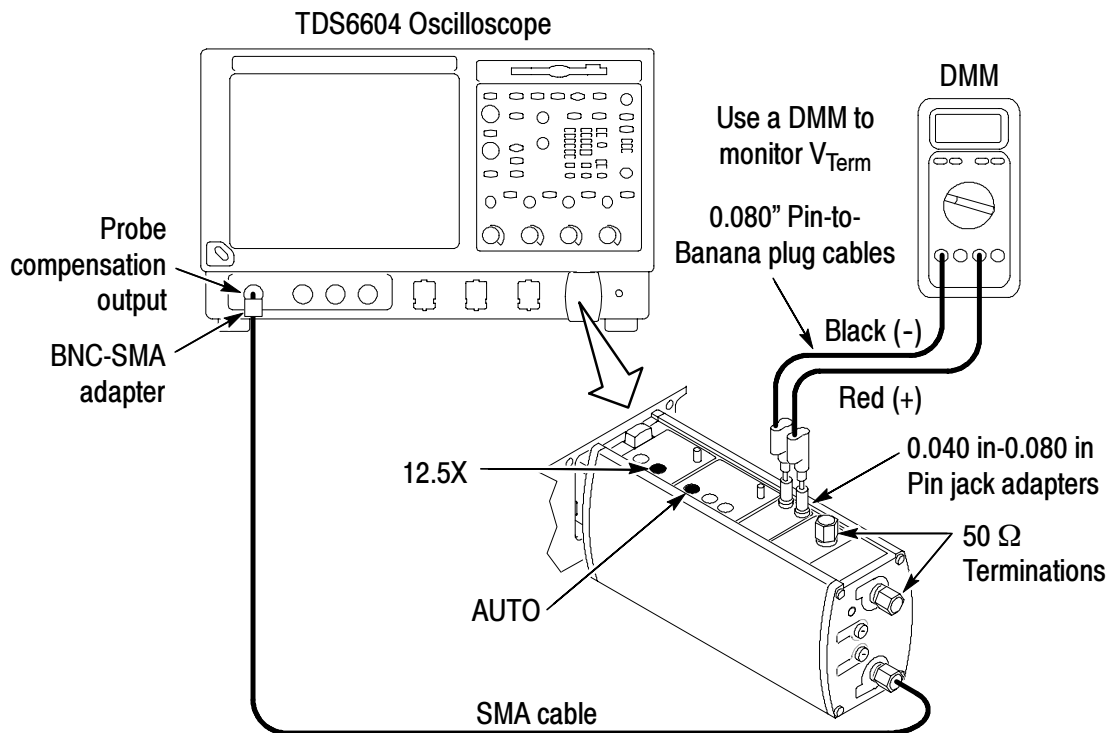
*If both Range Select LEDs flash or otherwise appear to be malfunctioning after power-on, an error condition may exist. See Appendix C: User Service for instructions on clearing errors.*

---

Next, perform the Signal and Termination Voltage Monitor Check. This test uses the PROBE COMPENSATION output on the front panel of the oscilloscope to verify that the probe input circuits function. The termination voltage monitor output is also checked, using a DMM. Figure 4 on page 17 illustrates a typical setup.

### Signal and Termination Voltage Monitor Check

1. Connect the BNC-SMA adapter (included with your probe) to the PROBE COMPENSATION connector on the oscilloscope.
2. Connect an SMA cable between the adapter and the (+) SMA probe input. (You can use one cable of the matched-delay cable set included with your probe.)
3. Connect 50  $\Omega$  SMA terminations to the (-) SMA probe input and the Aux output connectors.
4. Set the DMM to measure DC voltage and connect it to the Vterm monitor jacks using the 0.040 in-to-0.080 in adapters and the 0.080 in pin-to-banana plug test leads included with the probe. The test setup is shown in Figure 4.



**Figure 4: Signal check setup**

5. Using the SELECT buttons on the probe, set the attenuation on the probe to 12.5X, and set Vterm source to Auto.

6. Press Autoset or adjust the oscilloscope to display a stable calibration waveform. A stable square wave indicates that the probe is functional on the 12.5X attenuation setting.
7. The probe compensation signal amplitude and common mode voltage is dependent on oscilloscope model. Check that the signal amplitude on the oscilloscope and the common mode voltage (displayed on the DMM) approximate those in the table:

<b>P7380SMA Probe @ 12.5X Attenuation</b>	<b>TDS6604</b>	<b>TDS7704</b>
Signal amplitude	200 mV p-p	500 mV p-p
$V_{CM}$	900 mV	-250 mV

Refer to *Single-Ended Measurements* for more information on the measured common mode input voltage.

This completes the 12.5X attenuation signal check. If you want to check the 2.5X attenuation setting of the probe, do steps 8 through 11.

8. Insert a 50  $\Omega$ , 5X attenuator in-line with the probe compensation output connector. The attenuator is necessary to bring the probe compensation signal within the dynamic range of the probe at the lower attenuation setting. Without this attenuator, the probe amplifier in the 2.5X attenuator setting will be overdriven and the display will show a limited DC level instead of the probe compensation square wave.

You can use a BNC-style 5X attenuator, Tektronix part number 011-0060-03, or SMA-style 5X attenuator, Tektronix part number 015-1002-01.

9. Set the attenuation on the probe to 2.5X.
10. Press Autoset or adjust the oscilloscope to display a stable calibration waveform. A stable square wave indicates that the probe is functional on the 2.5X attenuation setting.

- 11.** The probe compensation signal amplitude and common mode voltage is dependent on oscilloscope model. Check that the signal amplitude on the oscilloscope and the common mode voltage (displayed on the DMM) approximate those in the table:

<b>P7380SMA Probe @ 2.5X Attenuation</b>	<b>TDS6604</b>	<b>TDS7704</b>
Signal amplitude	40 mV p-p	100 mV p-p
$V_{CM}$	180 mV	-50 mV

### Aux Output Check

The Aux output signal is an inverted, attenuated sample of the signal that is displayed on the main output of the probe.

1. Set the attenuation on the probe to 12.5X.
2. Remove the 50  $\Omega$  termination from the Aux output connector.
3. Connect an SMA cable from the probe Aux output to another channel on the oscilloscope, using a Tektronix TCA-SMA adapter. See Figure 5 for the test setup. (You can use the other cable of the matched-delay cable set included with your probe.)

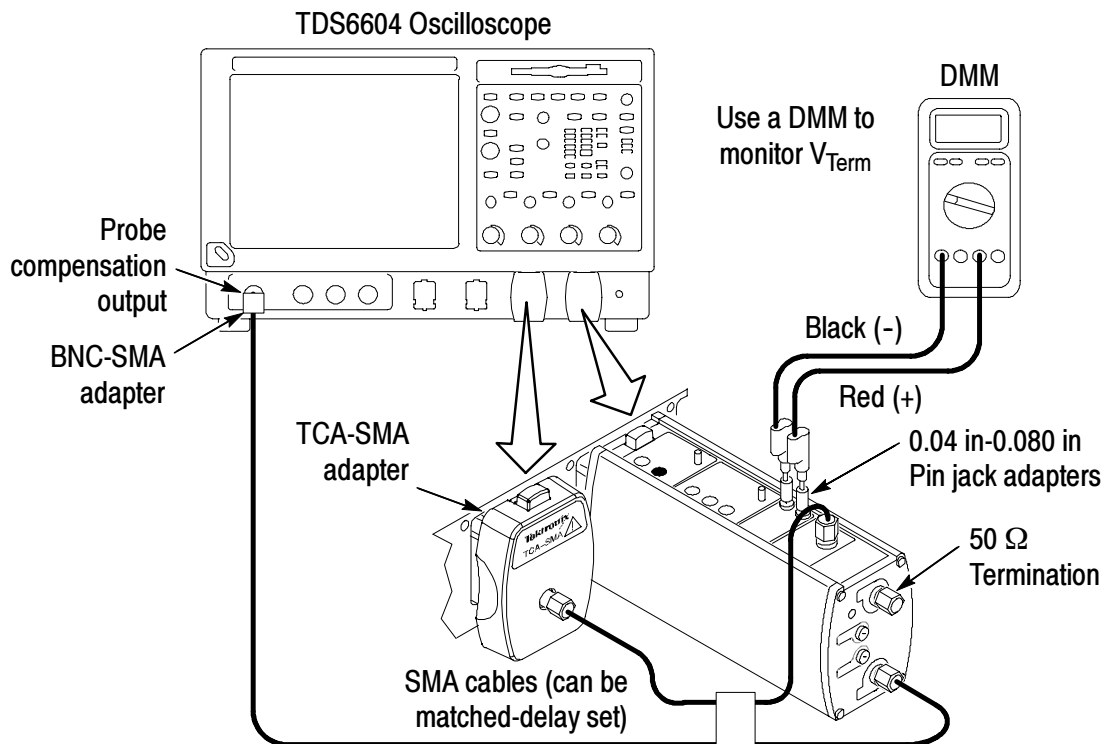


Figure 5: Aux output check test setup

4. Display the channel that you connected the Aux Output signal to, and check that the Aux Output signal is an inverted sample of the probe compensation signal that is displayed on the P7380SMA main output.

Also note that the Aux Output amplitude is attenuated by a factor of 12.5X from that displayed on the P7380SMA main output.

This is a result of the intelligent probe interface that adjusts for the selected attenuation factor on the main probe output.

This completes the 12.5X attenuation Aux Output signal check. If you want to check the 2.5X attenuation setting of the probe, do step 5. Note: This check requires the 5X external attenuator as described in step 8 on page 18.

Due to the combination of the 5X attenuator and the 5X increase in the probe gain (from 12.5X to 2.5X), the amplitude of the measured signal in the 2.5X attenuation check in step 5 will match that of the 12.5X attenuation check in step 4.

5. Insert a 50  $\Omega$ , 5X attenuator in-line with the probe compensation output connector, set the attenuation on the probe to 2.5X and check that the signal amplitude is the same as in step 4.

### DC Termination Voltage Zero Check

This test checks that the termination voltage defaults to 0 volts under the conditions shown below for the three different termination voltage selection modes.

#### Auto Mode.

1. Disconnect the SMA cables from the (+) input of the probe and the Aux output connector.
2. Connect 50  $\Omega$  SMA terminations to the (+) input of the probe and the Aux output connector.
3. Leave the 50  $\Omega$  SMA termination connected to the (-) input.

The test setup is shown in Figure 6 on page 22.

4. Use the Vterm SELECT button on the probe to set the Vterm mode to AUTO. Check that the DMM displays the termination voltage of approximately 0 V.

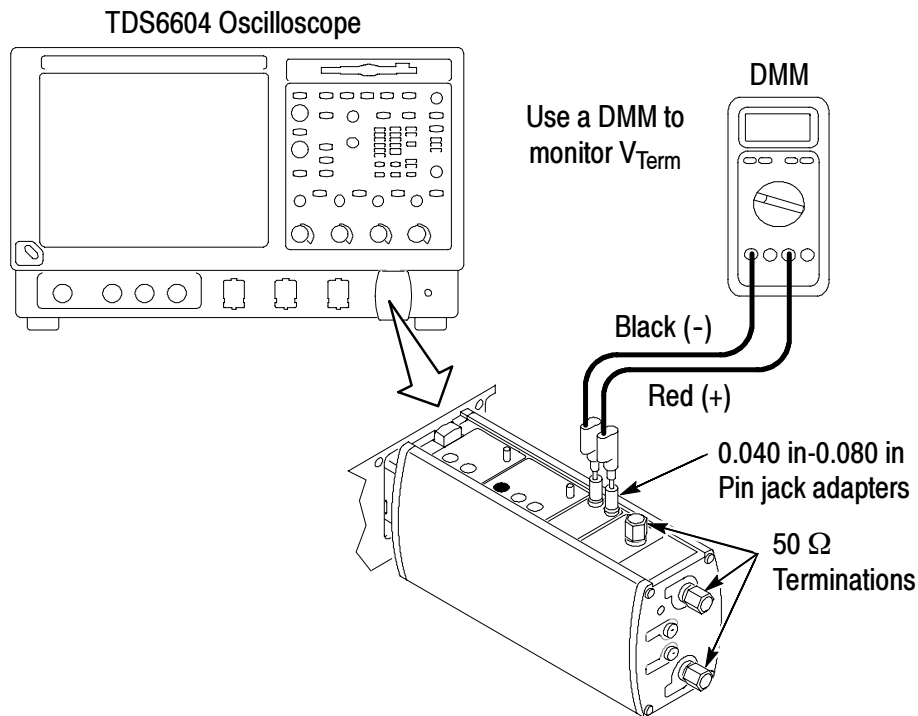


Figure 6: DC termination voltage check setup

**Int Mode.**

5. Use the Vterm SELECT button on the probe to set the Vterm mode to INT.

The DMM should display the termination voltage of approximately 0 V. If not, check that the oscilloscope has an internal Vterm control set to a voltage other than zero. See your oscilloscope manual for details on using the internal Vterm controls.

**Ext Mode.**

6. Verify that the external termination voltage inputs on the probe are open.
7. Use the Vterm SELECT button on the probe to set the Vterm mode to EXT. Check that the DMM displays the termination voltage of approximately 0 V.

This completes the functional check of the probe. If your instrument supports probe calibration routines, now is a good time to perform them. See *Probe Calibration* on page 24 for instructions.



## Probe Calibration

After you perform a functional check of the probe, run a probe calibration routine. The purpose of calibrating the probe is to optimize the gain and offset of the probe and oscilloscope combination to minimize measurement errors.

The Calibration Status of the instrument Signal Path Compensation test must be **pass** for the probe calibration routine to run:

1. From the Utilities menu, select Instrument Calibration.
2. In the Calibration box, check that the Status field is **pass**. If it is not, disconnect all probes and signal sources from the oscilloscope, and run the Signal Path Compensation routine.

When the Signal Path Compensation test status is **pass**, run the probe calibration routine:

3. Connect the probe to one of the oscilloscope channels, and set the oscilloscope to display the channel. Allow the probe to warm up for 20 minutes.
4. Connect the SMA cable from the PROBE COMPENSATION connector on the oscilloscope to the (+) SMA probe input.

---

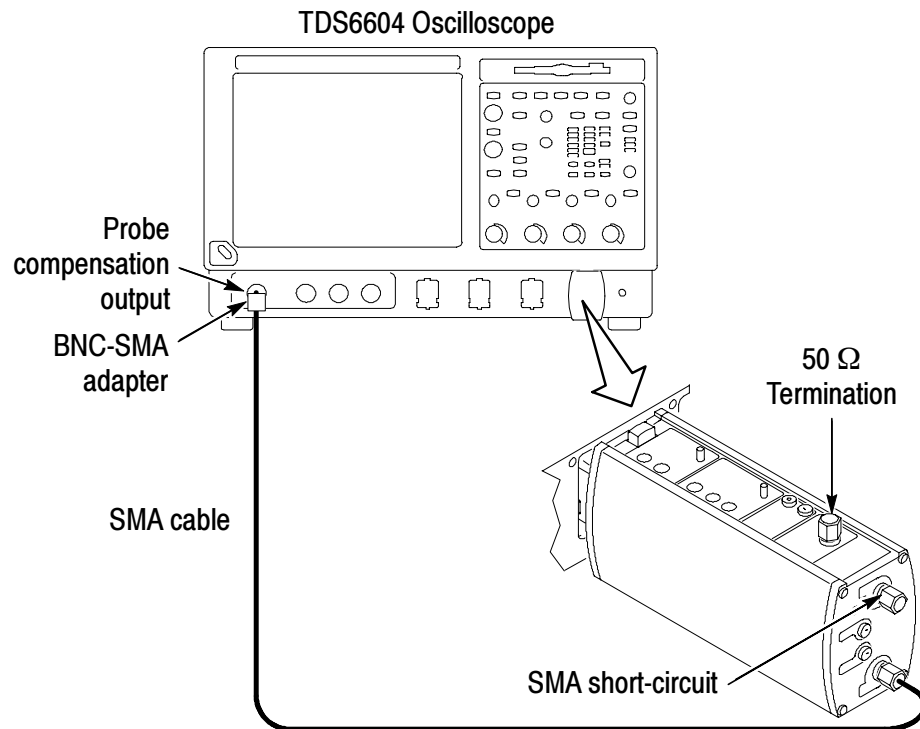
**NOTE.** *Some oscilloscopes, such as the TDS6804B, have a separate Probe Cal output rather than the Probe Compensation output for probe calibration.*

*For probe calibration with a TDS6804B oscilloscope, or other models that have a separate Probe Cal output, a BNC-SMA adapter should be attached to the Probe Cal output and the + SMA probe cable input should be connected to the adapter.*

---

5. Connect a short-circuit SMA termination to the (-) input of the probe.

The test setup is shown in Figure 7 on page 25.



**Figure 7: Probe calibration setup**

6. From the Vertical menu, select Probe Cal.
7. Press or click Calibrate probe.

The probe calibration routine runs, optimizing the probe to the oscilloscope for both probe attenuation settings.

After the probe passes the functional checks and probe calibration routine, you can use the probe in your measurement system. If your probe fails the functional checks or probe calibration routine, see *Appendix C: User Service*.

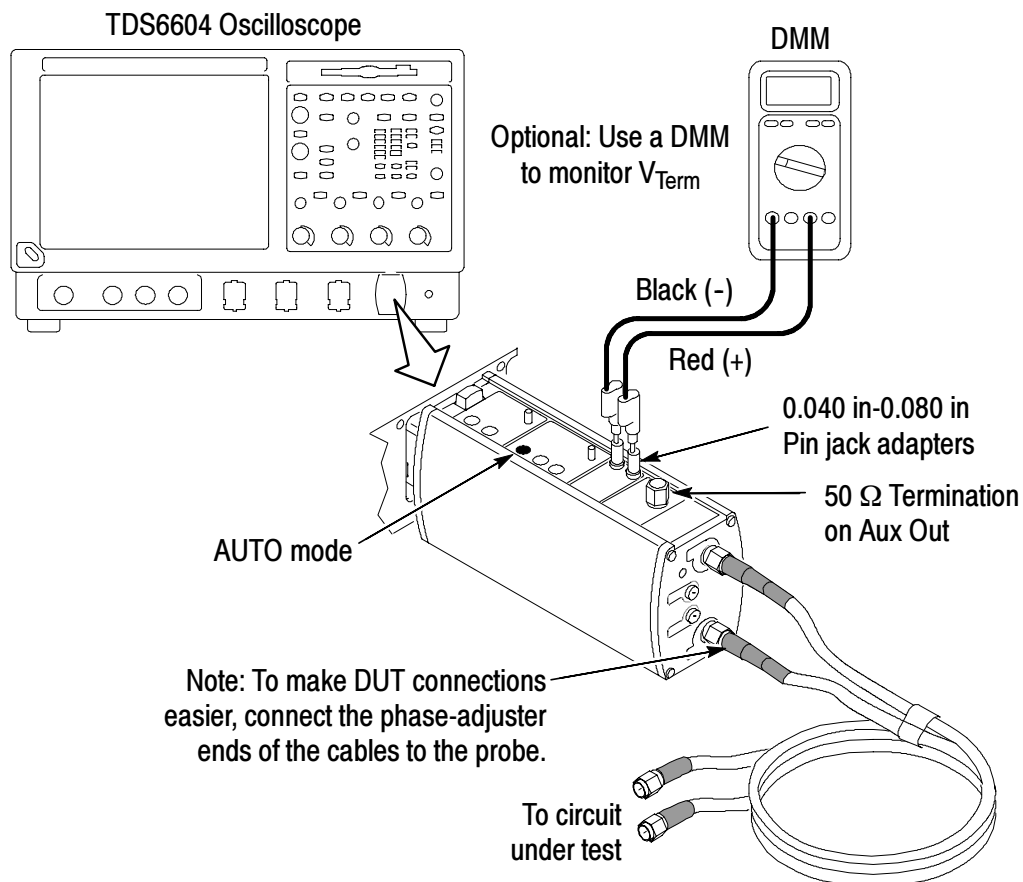
You can use the probe to make both single-ended and differential measurements. The following pages show some of the ways that you can use your probe.

## Using the Probe

The termination voltage control modes allow you to monitor and/or control the termination voltage using three different methods. If you are using a second measurement instrument, such as a spectrum analyzer, the auxiliary output provides an attenuated, inverted sample of the input signal for additional processing. The following figures illustrate some typical probe configurations and applications.

### Auto Mode

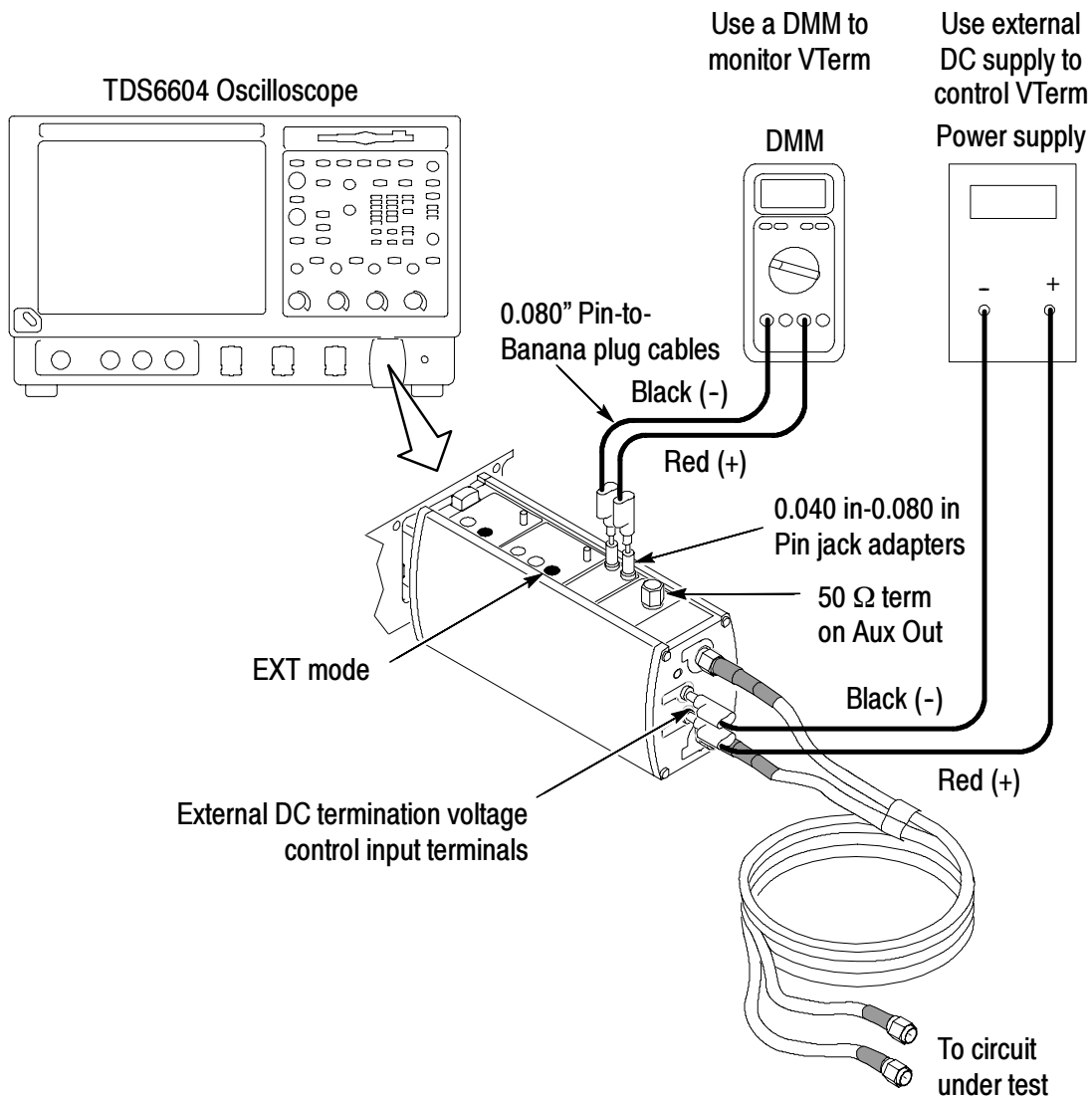
Figure 8 shows the probe connections for testing 50  $\Omega$  serial data lines, such as InfiniBand or PCI Express. In this example, Auto mode is used to automatically set the termination voltage. By matching the termination voltage to the input signal common mode voltage, Auto mode minimizes the DC loading on the differential input source.



**Figure 8: Using Auto Termination Voltage Control Mode**

### External Mode

For applications where you want to control the termination voltage, set the Vterm source to Ext mode and connect the termination voltage control inputs to an external power supply, as shown in Figure 9. You can use a DMM to verify that the termination voltage matches the externally-supplied DC control voltage.

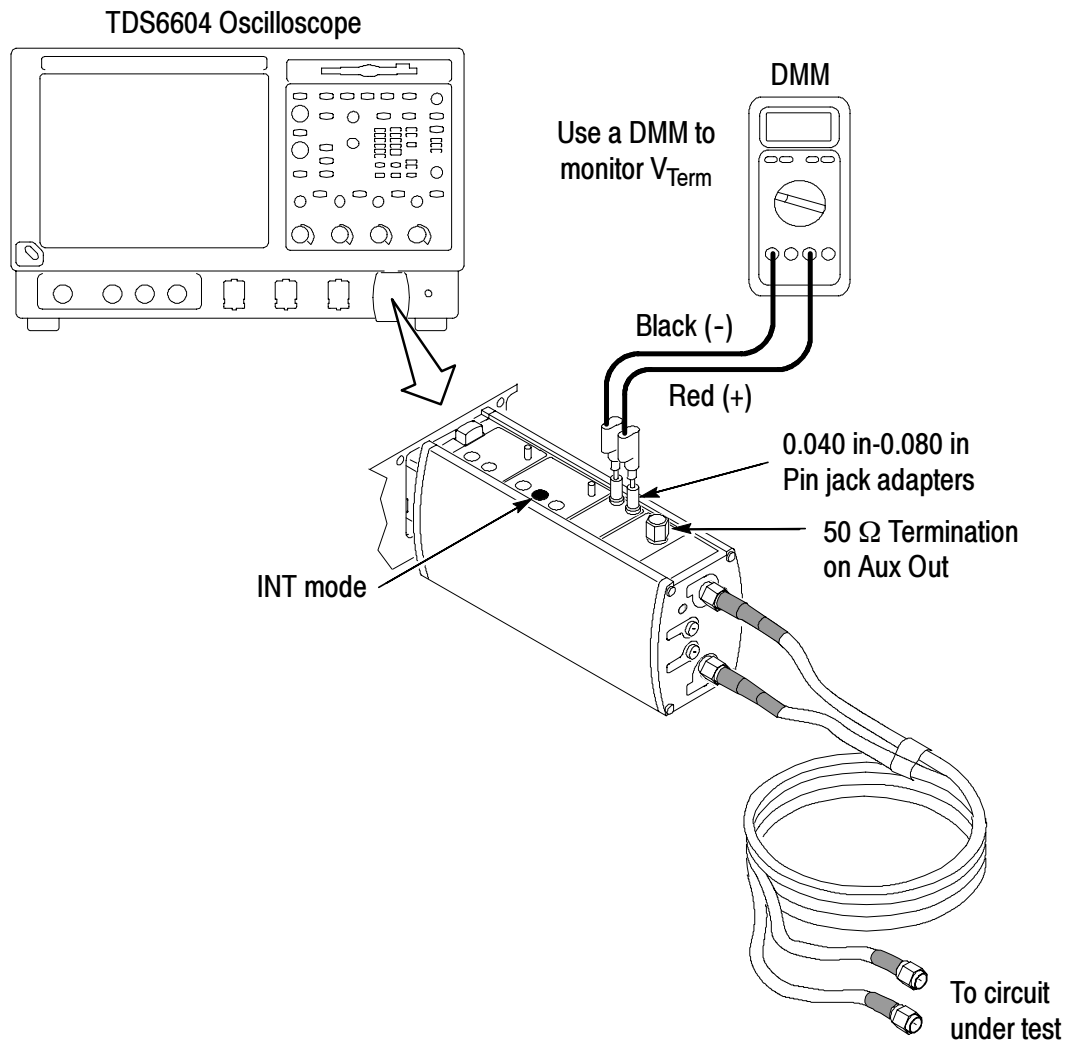


**Figure 9: Using External Termination Voltage Control Mode**

### Internal Mode

For TekConnect-interface oscilloscopes that support Int mode, you can use this feature to generate termination voltages with the oscilloscope, using the graphical user interface. This eliminates the need for an external power supply. Figure 10 shows the setup.

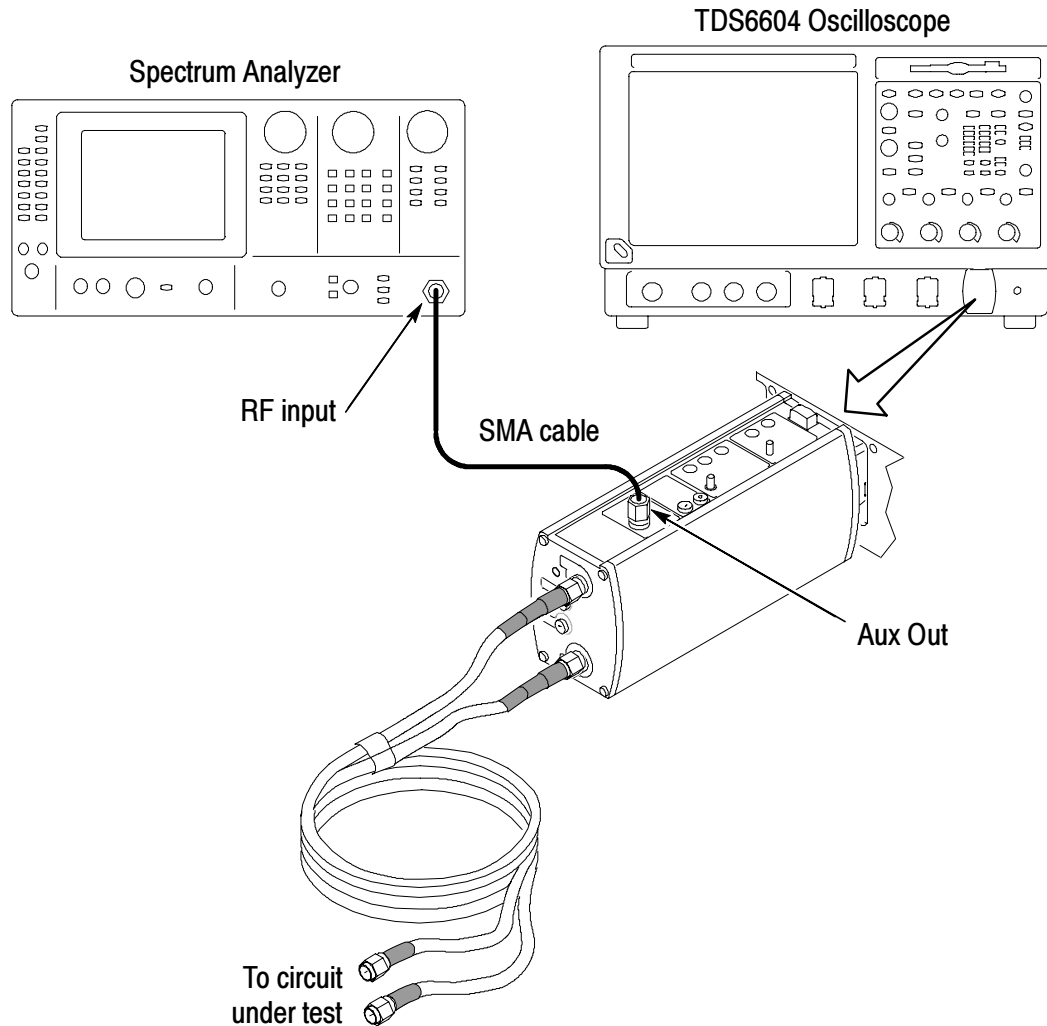
Refer to your oscilloscope manual for details on using the interface.



**Figure 10: Using Internal Termination Voltage Control Mode**

### Auxiliary Output

The Aux out connection can be used to connect to a spectrum or network analyzer, or for generating clock recovery signals used for other instrumentation. See Figure 11.



**Figure 11: Viewing the Aux Out signal on a spectrum analyzer**

### **Using the Probe With a Sampling Oscilloscope**

You can use the P7380SMA probe with Tektronix TDS/CSA8000 Series sampling oscilloscopes, using the Tektronix 80A03 TekConnect Probe Interface. The 80A03 interface is an optional accessory for the probe that adapts TekConnect probes to 8000 Series oscilloscopes.

The 80A03 interface uses 80E0X Series electrical modules that are part of the Tektronix 8000 Series oscilloscope family.

---

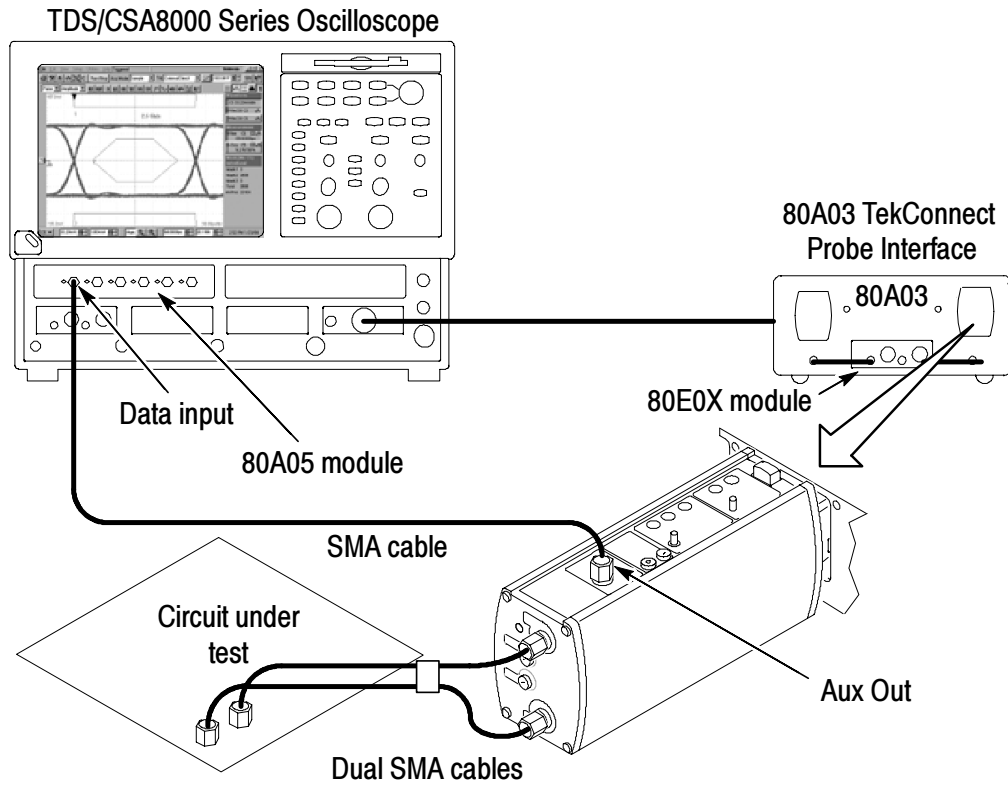
**NOTE.** *The firmware of your 80A03 interface must be version 1.2 or higher to be compatible with your P7380SMA probe.*

---

### **80A05 Clock Recovery Module.**

By adding an 80A05 Clock Recovery Module to your sampling oscilloscope, you can use the Aux output of your P7380SMA probe to trigger the module on the input signal and view eye diagrams. The 80A05 module generates a recovered clock from an acquired data stream when the data rate is known. Figure 12 on page 31 shows a test setup.

If a clock signal rather than a data signal is acquired by the probe, then the Aux output can be connected to one of the oscilloscope external trigger inputs.



**Figure 12: Using the probe with an 80A03 Interface and an 80A05 Module to view eye diagrams on a TDS8000 Series sampling oscilloscope**

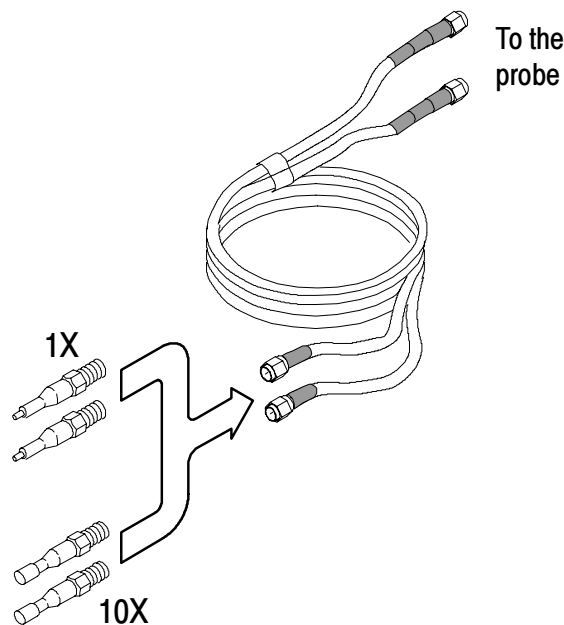


### P6150 Probe Tips

The P6150 probe is an optional accessory for the P7380SMA differential probe. The low-capacitance probe tips included with the P6150 probe provide a way for you to take measurements from test points other than SMA connectors.

For best results, use the matched SMA cable set included with your P7380SMA probe to connect between the P7380SMA probe and the P6150 probe tips.

Be aware of the tradeoffs between dynamic range and noise when using the 10X probe tips with the attenuation set at 12.5X. Also note that the vertical scale of the oscilloscope will be off by a factor of 10 when using the 10X tips.



**Figure 13: P6150 probe tips**

If you need to probe two points that are farther apart than the matched SMA cable set will allow, only use matched, high-quality, low loss SMA cables, and deskew them before attaching the probe tips. See *Checking Cable Skew* on page 57 for instructions.

# Operating Basics

This section discusses differential measurements using an SMA input probe for Serial Data compliance testing. It also provides information on the probe architecture and operation details to aid in its proper application.

## Differential Measurements for Serial Data Compliance Testing

### Differential Signalling

Gigabit serial data signals are commonly transmitted using differential signaling techniques because of improved signal fidelity and noise immunity. Although the physical layer specifications differ somewhat between the different gigabit serial data communication standards, they have some common elements. Most gigabit serial data signals are transmitted over 50  $\Omega$  transmission lines which are terminated at both ends of a point-to-point differential interconnect. The signal transmitter provides a 50  $\Omega$  source impedance from each of its two differential outputs and the signal receiver provides an effective 50  $\Omega$  input impedance on each of its two differential inputs.

The two complementary single-ended signals that comprise the differential signal are generally offset from ground at a common-mode voltage level, which allows the use of unipolar transmitters and receivers that are powered from a single power supply voltage. The transmitted signals are usually encoded using a DC-balanced encoding technique that allows the signals to be either AC or DC coupled in the transmission path. If DC coupled, the receiver termination must generally be terminated to the same DC common-mode voltage as the transmitter, to reduce DC loading on the transmitter output. An example of the single-ended signals transmitted by an InfiniBand standard driver and the resultant differential signal that would be measured by a differential measurement system is shown in Figure 27 on page 64.

Although the differential response is generally the primary measurement of interest for a differential signal, full characterization of the signal also requires measurement of the single-ended response of the two complementary signals including the DC common-mode voltage.

### **Pseudo-Differential Measurements**

A common differential measurement technique uses two single-ended probes or direct connection to two oscilloscope channels for the differential signal capture. By calculating the difference between the two input signals using waveform math, the effective differential signal seen by a differential receiver can be displayed for analysis.

This measurement technique, which is commonly referred to as pseudo-differential measurement, has a number of limitations when compared to the use of a differential probe like the P7380SMA. In addition to the obvious overhead of two oscilloscope channels for the measurement instead of the single channel needed by a differential probe, there are a number of additional problems.

Unlike the differential probe, which has been carefully designed with short, matched-input signal paths, a pseudo-differential measurement uses two oscilloscope channels which are physically separated and generally not matched as well. Although it is possible to deskew the timing differences between two high performance oscilloscope channels to improve the accuracy of a pseudo-differential measurement, deskewing is a relatively involved procedure that may need to be repeated if any oscilloscope parameter, such as vertical gain, is changed.

The gain match between two different oscilloscope channels is also a potential problem, particularly at higher frequencies where channel gain mismatch can contribute to significantly reduced CMRR performance. The CMRR performance of a differential probe, on the other hand, is generally much better controlled, with fully characterized specifications over the full probe bandwidth.

The requirement of generating a math waveform for display of the differential signal in a pseudo-differential measurement can also introduce some subtle problems with waveform analysis, since some features such as COMM triggering or mask testing may not be fully supported with math waveforms. The use of a differential SMA-input

probe like the P7380SMA also provides additional features like adjustable termination voltage that may be very useful in fully characterizing the performance of differential data transmitters. High performance oscilloscope channels are almost always limited to zero volt termination voltage, since the oscilloscope termination resistor is connected directly to signal ground.

### **Differential Probe Measurements**

A differential probe is designed to provide a differential input interface for a single-ended oscilloscope channel. It includes a carefully matched differential signal input path and a differential buffer amplifier.

A conventional differential probe input generally has a high DC input resistance and as small an input loading capacitance as possible. The light input loading of a conventional differential probe is designed to perturb the circuit being measured as little as possible when the probe is attached.

An SMA-input probe like the P7380SMA has a very different input structure. It has a dual, matched 50  $\Omega$  input that is designed to terminate the measured signal transmission path with minimum reflections. It is designed specifically for serial compliance testing. Its SMA input connectors provide a reliable, repeatable interconnect for making accurate eye pattern measurements that are used to characterize the quality of a serial data transmission channel.

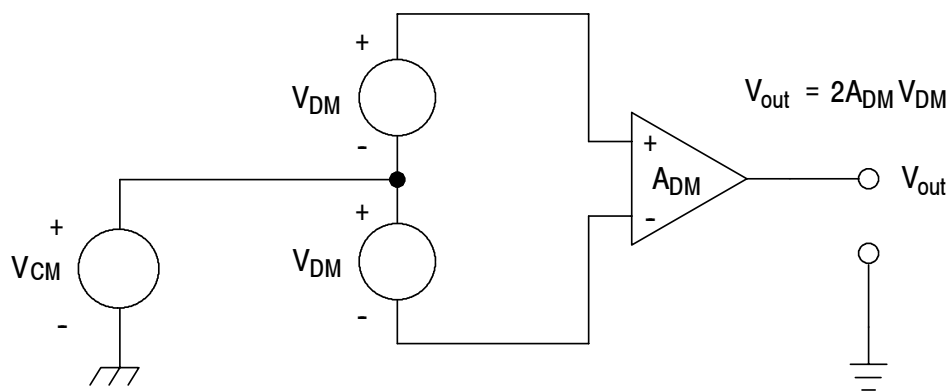
The P7380SMA probe has also been carefully designed for flat amplitude response and very small pulse response aberrations. This helps to ensure accurate eye pattern measurements over a wide data rate range.

The differential amplifier (see Figure 14 on page 36) is at the heart of any device or system designed to make differential measurements. Ideally, the differential amplifier rejects any voltage that is common to the inputs and amplifies any difference between the inputs. Voltage that is common to both inputs is often referred to as the Common-Mode Voltage ( $V_{CM}$ ) and difference voltage as the Differential-Mode Voltage ( $V_{DM}$ ).

The simplified input signal voltage source model driving the differential amplifier in Figure 14 shows a complementary

differential signal without source or termination impedance. In a real-world measurement, the signal source and measurement termination impedance must be known and included in the measurement analysis.

The model in Figure 14 also shows that the output from the differential amplifier has twice the peak-to-peak amplitude of each complementary input signal.



**Figure 14: Simplified model of a differential amplifier**

### Common-Mode Rejection Ratio

In reality, differential amplifiers cannot reject all of the common-mode signal. The ability of a differential amplifier to reject the common-mode signal is expressed as the Common-Mode Rejection Ratio (CMRR). The CMRR is the differential-mode gain ( $A_{DM}$ ) divided by the common-mode gain ( $A_{CM}$ ). It is expressed either as a ratio or in dB.

$$CMRR = \frac{A_{DM}}{A_{CM}} \quad CMRR(dB) = 20 \log \frac{A_{DM}}{A_{CM}}$$

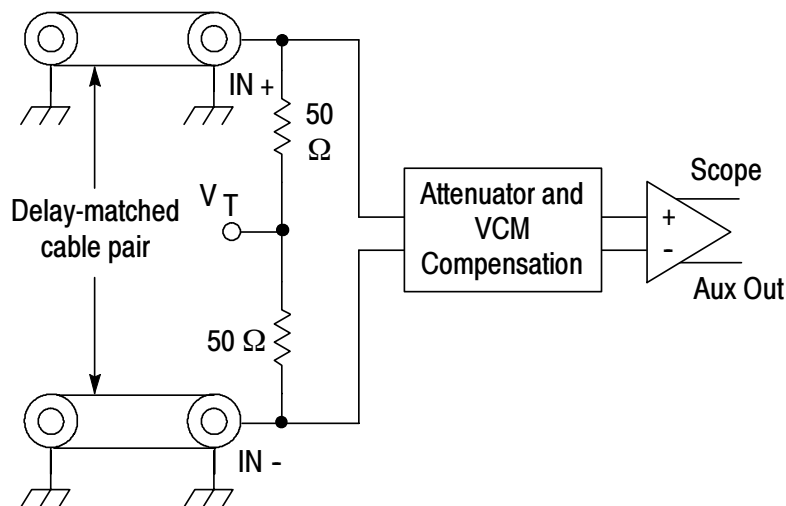
CMRR generally is highest (best) at DC and degrades with increasing frequency.

Figure 28 on page 68 shows the typical CMRR response of the P7380SMA differential probe over frequency. High CMRR in a differential probe requires careful matching of the two input paths. Poorly matched signal source impedances can significantly degrade the CMRR of a measurement. Mismatches between the two differential signal input paths result in an effective conversion of  $V_{CM}$  to  $V_{DM}$ , which reduces the CMRR.

## Probe Block Diagram (Simplified)

The SMA inputs and probe termination network provide a high frequency,  $50\ \Omega$  signal path to the internal probe amplifier. The use of SMA-female connectors provides a reliable, repeatable attachment method for input signals. The symmetry of the input termination network is designed to reduce skew and maximize CMRR.

A simplified schematic of the P7380SMA input termination network is shown in Figure 15.



**Figure 15: Input termination network**

### Matched-Delay Cables

The standard delay-matched cables for the P7380SMA differential probe have been carefully designed to provide guaranteed probe

performance at the SMA connector interface on the end of the cable. The delay between the two matched cables in the standard cable assembly is adjusted to provide an initial skew of less than 1 ps. Cable skew this small can be degraded by cable flexure and through other environmental factors. Care should be taken to minimize physical mishandling of this quality cable assembly to preserve probe performance.

The cable used in the standard cable assembly has also been selected for its low-loss characteristics, and the cable length was selected to match the cable loss compensation designed into the probe differential amplifier. If an alternative cable assembly is used in measurements with the P7380SMA differential probe amplifier, this loss compensation characteristic must be considered. The following approximate equation for cable loss compensation can be used as a guideline in custom cable designs and is valid over a frequency range of about 1 GHz to 8 GHz:

$$\text{Loss} = 0.5\text{dB} + 0.15\text{dB} * (F - 1), \text{ where } F \text{ is frequency in GHz}$$

Custom cable pairs must also be designed with very low skew or the skew must be minimized using a pair of adjustable phase trimmer adapters like those listed in the *Optional Accessories* on page 8.

### **Input Termination Network**

The input termination network in the P7380SMA differential probe includes a pair of laser trimmed 50  $\Omega$  termination resistors, connected together at a common-mode voltage node, labeled  $V_T$  in Figure 15. The common-mode termination voltage node,  $V_T$ , is designed to provide a broadband, low impedance termination for input common-mode signals. The probe termination voltage can be adjusted using several different modes that will be described later.

The termination voltage range is  $\pm 2.5$  V, which matches the allowable input signal common-mode voltage range. For DC-coupled serial data signals, the termination voltage,  $V_T$ , should generally be set to equal the input signal common-mode voltage,  $V_{CM}$ ; for AC-coupled serial data signals, the termination voltage,  $V_T$ , should generally be set to 0 V.

The adjustability of the termination voltage also provides measurement flexibility for characterizing or stressing serial data signal drivers. Because of the low impedance of the input termination and attenuator network, the signal termination currents can become quite large. Table 5 below can be used to calculate the DC common-mode voltages and currents at the probe inputs and termination voltage driver under several common source impedance conditions.

**Table 5: Common-mode voltage and current table**

	Source impedance <sup>1</sup>	
	0 Ω	50 Ω
$V_I$	$V_{CM}$	$0.5 \times (V_T + V_{CM})$
$I_I$	$40.00 \text{ mA} \times V_T - 40.00 \text{ mA} \times V_{CM}$	$20.00 \text{ mA} \times V_T - 20.00 \text{ mA} \times V_{CM}$
$I_T$	$40.00 \text{ mA} \times V_T - 23.33 \text{ mA} \times V_{CM}$	$28.33 \text{ mA} \times V_T - 11.67 \text{ mA} \times V_{CM}$

<sup>1</sup> When inputs are AC coupled:  $V_I = V_T$ ,  $I_I = 0$ ,  $I_T = 16.67 \text{ mA} \times V_T$

The probe block diagram shows that the input termination network is followed by an attenuator and  $V_{CM}$  compensation circuit. The attenuator is used to increase the effective input dynamic range of the probe differential amplifier.

The P7380SMA probe has two attenuation settings, 2.5X and 12.5X, that allow dynamic range to be traded off against signal noise. The 12.5X attenuator setting has the largest dynamic range; the 2.5X attenuator setting has the lowest noise.

The  $V_{CM}$  compensation circuit automatically minimizes the DC common-mode voltage at the probe differential amplifier inputs even with varying termination voltage and input signal DC common-mode voltage. This maximizes the differential mode signal input dynamic range. The  $V_{CM}$  compensation circuit allows the DC common-mode input voltage range to be the same for both attenuator settings as shown in Figure 17 on page 43.



### Internal Probe Amplifier

The P7380SMA differential probe is designed to measure high frequency, low-voltage circuits. Before connecting the probe to your circuit, take into account the limits for maximum input voltage, the common-mode signal range, and the differential-mode signal range. For specific limits of these parameters, see Figure 17 on page 43 and *Specifications* starting on page 65.

### Maximum Input Voltage.

The maximum input voltage is the maximum voltage to ground that the inputs can withstand without damaging the probe input circuitry.



**CAUTION.** *To avoid damaging the inputs of the P7380SMA differential probe, do not apply more than  $\pm 5$  V (DC + peak AC) between each input and ground. In addition, the maximum termination resistor power must not be exceeded to avoid probe damage.*

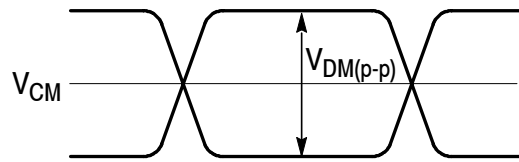
---

### Maximum Termination Resistor Power.

The internal termination resistors can safely dissipate 0.2 W of power continuously, which is the case for normal probe operation without termination driver current overload. However, the probe will be damaged if you apply more than 0.5 W of power through the termination resistors for more than 5 minutes.

If you suspect your measurement application will approach these limits, use the formulas that follow to calculate the power dissipated by the termination resistors.

The power calculation formulas are based on the simplified model shown in Figure 16 on page 42, which represents the signal at the probe inputs. If a signal source with 50  $\Omega$  source impedances is used, the signal levels used should match the zero-ohm source impedance model in Figure 16.



$$\text{DC power} = \left[ \frac{V_{\text{CM}} - V_{\text{T}}}{50} \right] (V_{\text{CM}} - V_{\text{T}}) \text{ per side}$$

$$\text{AC power} = \left[ \frac{V_{\text{DM(p-p)}}}{100} \right] \left[ \frac{V_{\text{DM(p-p)}}}{2} \right] \text{ per side}$$

The signal source model defined for these equations is as follows:

$V_+$  and  $V_-$  = Single-ended signals into a 50  $\Omega$  load

$$V_+ = V_{\text{CM}} + V_{\text{DM}} \quad V_- = V_{\text{CM}} - V_{\text{DM}}$$

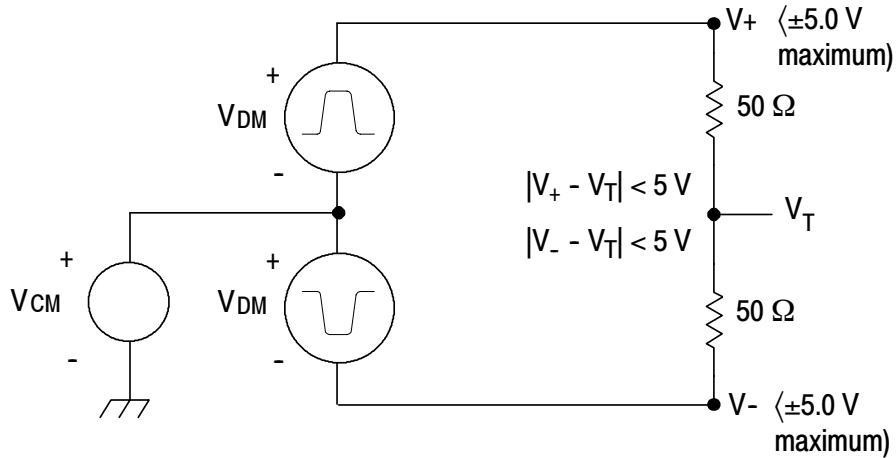
This results in the terms to be used in the power equations above:

$$V_{\text{CM}} = \frac{V_+ + V_-}{2} \quad V_{\text{DM}} = \frac{V_+ - V_-}{2}$$

$V_{\text{T}}$  = Termination input voltage

Note: With a balanced DC signal, in the equations above,  $V_{\text{DM}}$  is half of the value of a conventional differential signal.

$$V_{\text{diff}} = V_+ - V_- = 2V_{\text{DM}}$$



**Figure 16: Probe maximum input limits**

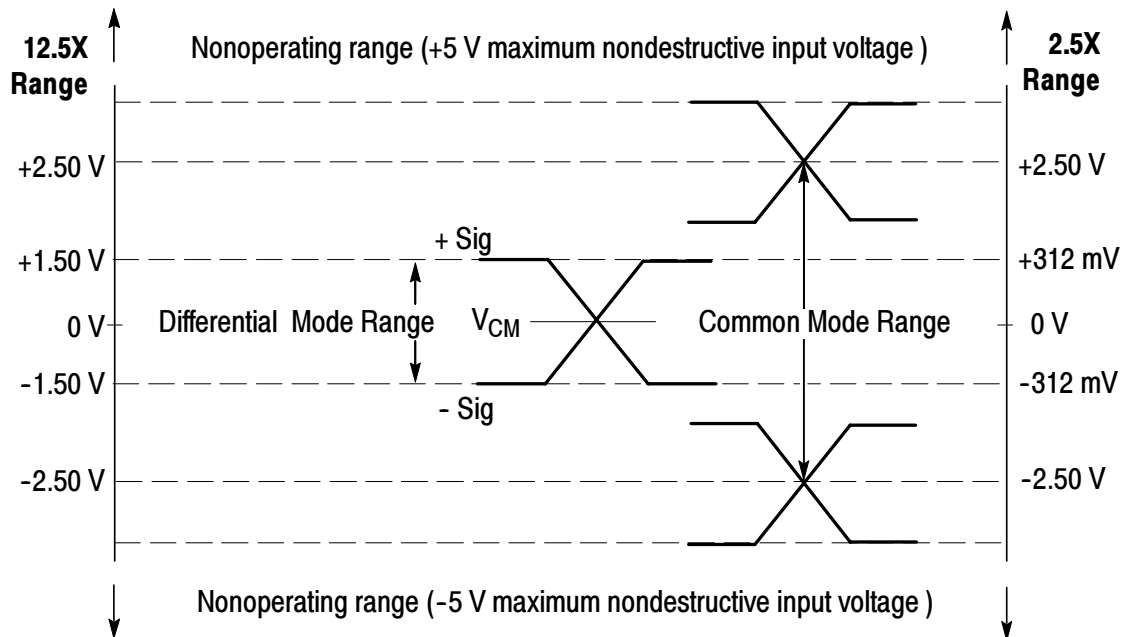
**Common-Mode Signal Range.**

The common-mode signal range is the maximum voltage that you can apply to each input, with respect to earth ground, without saturating the input circuitry of the probe. A common-mode voltage that exceeds the common-mode signal range may produce an erroneous output waveform even when the differential-mode specification is met.

**Differential-Mode Signal Range.**

The differential-mode signal range is the maximum voltage difference between the plus and minus inputs that the probe can accept without distorting the signal. The distortion from a voltage that is too large can result in a clipped or otherwise distorted and inaccurate measurement. The differential mode signal range is dependent on the probe attenuator setting as shown in Figure 17 on page 43.

For a more detailed description of the differential mode dynamic range, see *Differential Measurement Topology* on page 48.



**Figure 17: Differential and Common-Mode operating ranges**

### Common-Mode Rejection.

The common-mode rejection ratio (CMRR) is the ability of a probe to reject signals that are common to both inputs. More precisely, CMRR is the ratio of the differential-mode gain to the common-mode gain. The higher the ratio, the greater the ability to reject common-mode signals. For additional information about CMRR, see page 36.

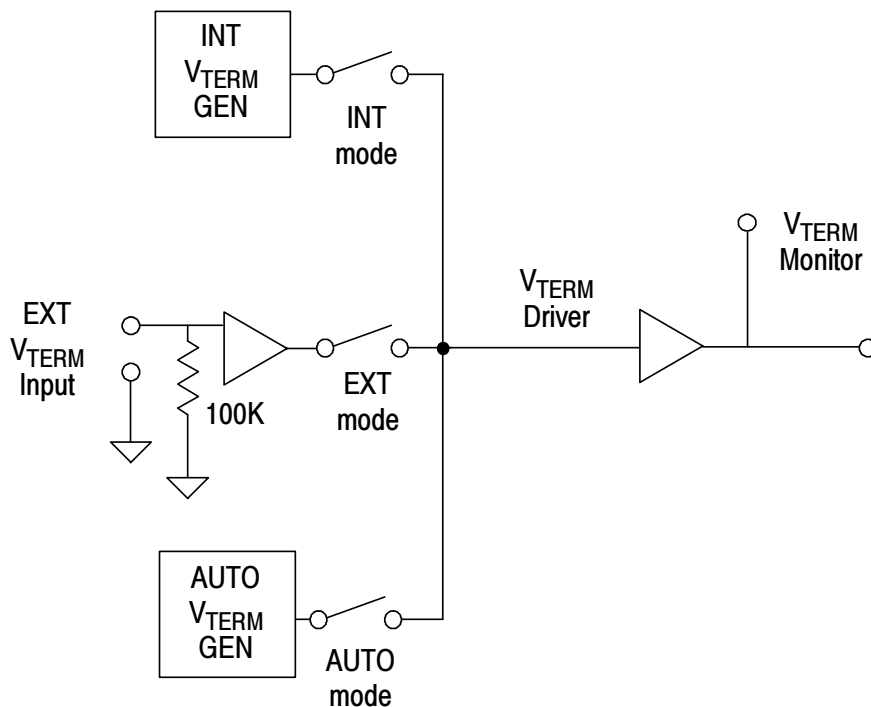
### Probe Amplifier Outputs.

The P7380SMA probe has a differential signal output. The positive polarity output is connected to the oscilloscope through the TekConnect probe interface. The inverted polarity output is connected to the Aux Output SMA connector on the top of the probe.

The positive polarity main output is automatically scaled by the intelligent TekConnect probe interface to compensate for probe attenuation and display the differential signal voltage at the probe inputs. The inverted Aux Output is an attenuated version of the differential signal input, which must be manually accounted for in signal measurements or processing.

## Termination Voltage Control

The P7380SMA probe termination voltage can be controlled either internally or externally, as selected by three different modes. A block diagram of the probe termination network is shown in Figure 18 below. A discussion of the circuitry follows.



**Figure 18: Termination voltage network drive**

The P7380SMA probe has been designed for compliance testing of high-speed, serial data standards such as PCI Express, InfiniBand, SerialATA, XAUI, Gigabit Ethernet, Fibre Channel, and others. All of these high-speed, differential data standards define a common-mode voltage less than the  $\pm 2.5$  V termination range of the P7380SMA probe.

The probe termination voltage can be set to the desired input signal common-mode voltage using one of three control modes: Auto, the default mode at power-on, Internal, and External. The operation of these modes are described below.

### Auto Mode

When the probe is first connected to the oscilloscope, a self test runs, and the default termination voltage control mode is set to Auto. When the probe is in Auto mode, the common-mode voltage of the input signal is monitored, and the DC termination voltage is set to match the common-mode input voltage. Auto mode provides the minimum DC loading on the input signal source.

With open inputs or a high DC source impedance, such as an AC-coupled input signal, the Auto mode select LED flashes, indicating that the termination voltage has been set to zero volts.

This is the mode that you will likely use for most compliance testing of current serial data standards.

### Int Mode

The internal mode allows you to set the termination voltage with user controls available on some TekConnect-interface oscilloscopes. You can adjust the DC termination voltage within the  $\pm 2.5$  V range. See your oscilloscope manual for details on using this mode.

### Ext Mode

When the probe is in external mode, it allows control of the DC termination voltage with an external power supply. You can adjust the DC termination voltage within the  $\pm 2.5$  V termination voltage range of the probe.

The external DC termination voltage control input is buffered by an internal amplifier with 100 K ohm input impedance.



---

**WARNING.** Do not exceed the  $\pm 15$  V external mode voltage maximum for the probe. Excess voltage will damage the probe.

---

In Ext mode, the external DC voltage is connected to the red (+) and black (-) terminals on the end of the probe head, which accept standard 80 mm plugs. A pair of 0.080 in-to-banana plug adapter cables are included with the probe for making connections from these connectors to external power sources. The black terminal is ground and is connected to the outer case of the shielded module that holds the SMA input terminals. When you are not using these

terminals, they can be left open and unconnected. When the Ext mode input terminals are left open, the Ext mode termination voltage defaults to 0.0 V.

The termination voltage supplied to the input termination network by the Vterm driver can be monitored with a DMM on a pair of 0.040 inch pin jacks on the top of the probe. This allows you to verify the termination voltage setting, and when you are using Auto mode, allows you to measure the common-mode input voltage.

You can use a pair of 0.040 inch-to-0.080 inch pin jack adapters with the 0.080 inch-to-banana plug cables (both are standard accessories included with your probe), to make a more permanent connection to the monitoring DMM.

## Overdrive Error

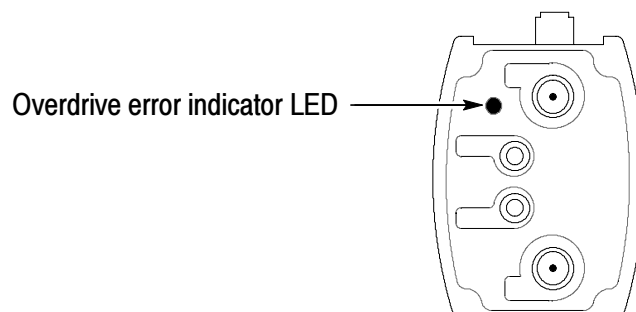
The P7380SMA differential probe can measure signals that have a common-mode voltage range of  $\pm 2.5$  V. Although the termination voltage range is also specified to be  $\pm 2.5$  V, limitations on the linear current range of the termination voltage driver restrict the voltage difference between  $V_{CM}$  and  $V_T$ .

Generally, you must keep the termination voltage within about 2.5 volts of the common-mode voltage, or the Overdrive Error LED will glow solid, indicating an over-current situation, which may lead to a measurement error.

The specific voltage difference between  $V_{CM}$  and  $V_T$  is dependent on both the source impedance and the  $V_{CM}$  and  $V_T$  values. You can use the input termination network table on page 39 to determine allowable conditions, with the Overdrive Error current threshold for  $I_T$  set at about  $\pm 80$  mA.

The Overdrive Error LED will also flash red when the termination voltage exceeds the allowable  $\pm 2.5$  volt range. This can occur in Auto mode when  $V_{CM}$  exceeds a threshold of about  $\pm 2.8$  V, or in Ext mode when the  $V_T$  input voltage exceeds the same threshold. If this occurs, remove all signal sources from the probe to clear this LED.

The Overdrive Error LED provides an active status monitor of error conditions; it does not latch and store the occurrence of an error condition.



**Figure 19: Overdrive Error indicator**

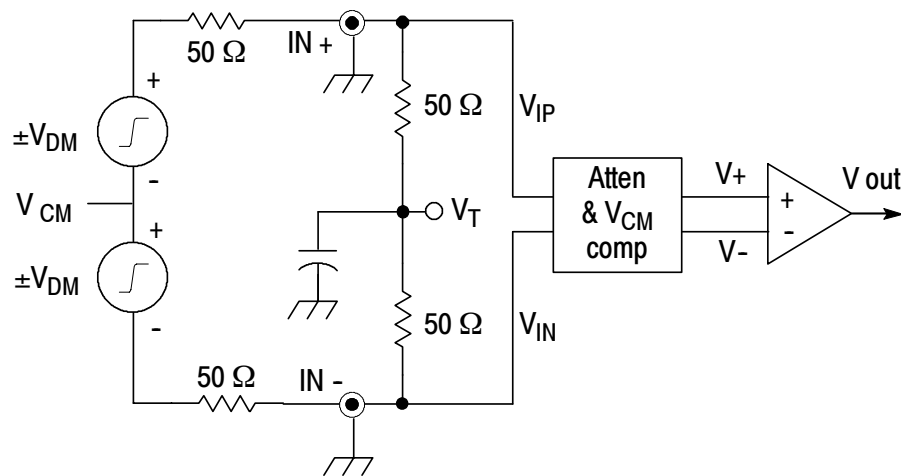


## Differential and Single-Ended Signal Measurement

Although designed for differential signal measurement, the P7380SMA probe can be used to make single-ended measurements when properly configured. The analysis that follows describes some differential and single-ended measurements of typical high-speed serial data signals.

### Differential Measurement Topology

A typical differential measurement topology using the P7380SMA probe is shown in Figure 20. The termination network for the probe in this figure includes a termination capacitor. This is intended to show that the termination network provides a broadband AC ground for common-mode signals.



**Figure 20: Differential measurement topology**

Although an ideal differential signal is theoretically terminated at the  $V_T$  node due to symmetry, the low impedance  $V_T$  node terminates any non-ideal, AC common-mode signal components. The input signal source model includes a common-mode component,  $V_{CM}$ , and complementary differential mode components,  $\pm V_{DM}$ .

The differential mode signal source models have double the signal amplitude of the measured signal at each input because of the  $50\ \Omega$  voltage divider between the source and termination resistance.

The common-mode signal source model does not have double the signal source amplitude because most serial data transmitters are designed to drive a load resistance terminated with the DC common-mode voltage, not signal ground.

With  $V_T$  set equal to  $V_{CM}$  in this model topology, the DC common-mode voltage at each probe input should equal  $V_{CM}$ . The resulting differential signals at the probe inputs are:

$$V_{IP} = V_{CM} + V_{DM} \quad V_{IN} = V_{CM} - V_{DM}$$

The attenuator and  $V_{CM}$  compensation network that follows the termination network nulls out the  $V_{CM}$  signal and attenuates the  $V_{DM}$  signals. The resulting differential signals at the probe amplifier inputs for a 2.5X attenuation setting are:

$$V_+ = 0.4V_{DM} \quad V_- = -0.4V_{DM}$$

The resulting output signal from the probe output is:

$$V_{out} = -0.8V_{DM}$$

The inverted polarity of the probe amplifier output can be verified by examining the probe Aux Output signal. The main probe output signal is routed through the TekConnect interface connector and is automatically scaled to show the correct differential amplitude at the probe input connectors.

### Differential Dynamic Range

The  $V_{CM}$  compensation circuit in the probe attenuator is designed to maximize the dynamic range of the AC component of the input signal. For most high-speed serial data signals, the AC component of the signal is of most interest for compliance testing where an eye pattern display of the differential signal is checked for timing jitter and voltage amplitude and fidelity.

The DC common-mode component of the input signal is present primarily to bias the signal into the operating range of the receiver and may even be removed in the transmission path with AC coupling. The  $V_{CM}$  compensation circuit in the P7380SMA probe is designed to null out the DC common-mode component of the input

signal,  $V_{CM}$ , so that only the differential mode component of the input signal is passed through to the probe amplifier inputs.

The  $V_{CM}$  compensation circuit allows the dynamic range of the probe to be specified as a differential peak-to-peak voltage with a separate DC common-mode range. The differential peak-to-peak voltage specification is different for the two probe attenuation settings, but the DC common-mode range is the same for both attenuation settings.

The DC common-mode range of the probe is actually describing the performance of the  $V_{CM}$  compensation circuit, rather than the dynamic range of the probe amplifier. The dynamic range of the probe has been specified as a differential peak-to-peak voltage because that best represents the way in which the signal is typically displayed and specified for compliance testing.

### **Single-Ended Measurement Topology**

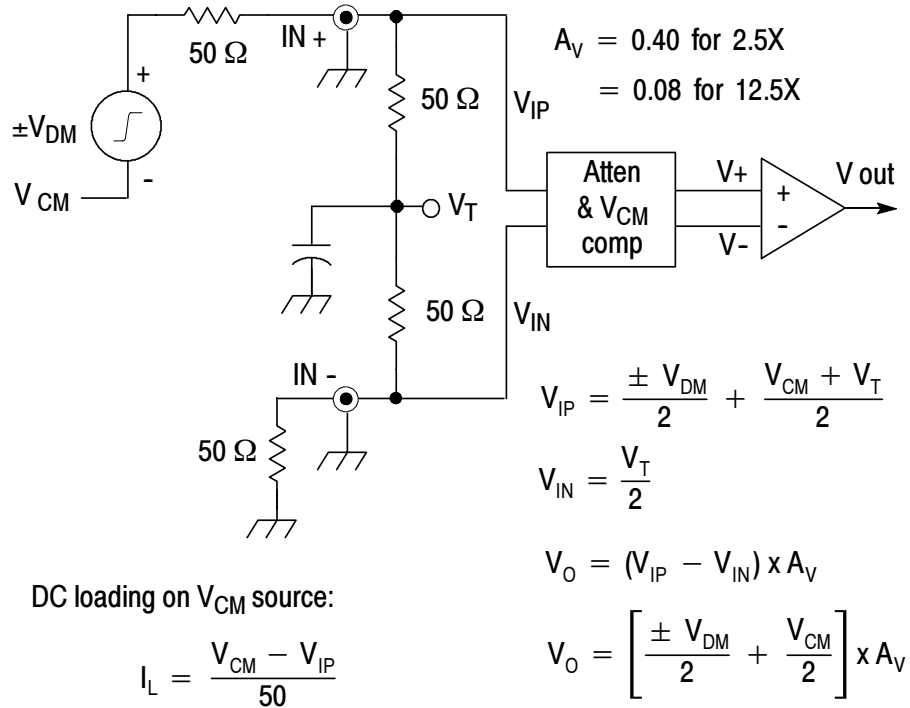
Although the P7380SMA differential probe can be used to make single-ended measurements, it is important to understand the impact of the termination network on the measured response, particularly on the DC common-mode component of the signal.

Because of the limited dynamic range of the probe amplifier, single-ended measurements, which also display the DC common-mode component of the signal, must be carefully checked for possible overdrive problems. The single-ended measurement topology can also affect the performance of Auto mode, which will only function properly with a matched source impedance configuration.

Three possible single-ended measurement topologies will be examined in this section. They differ in the termination used on the (-) input of the probe when the single-ended signal is connected to the (+) input.

**50 Ohm Termination on (-) Input.**

A single-ended measurement topology with a 50 Ω termination on the probe input is shown in Figure 21. The general equations that describe the response of that topology are also shown, including DC loading on the signal source.



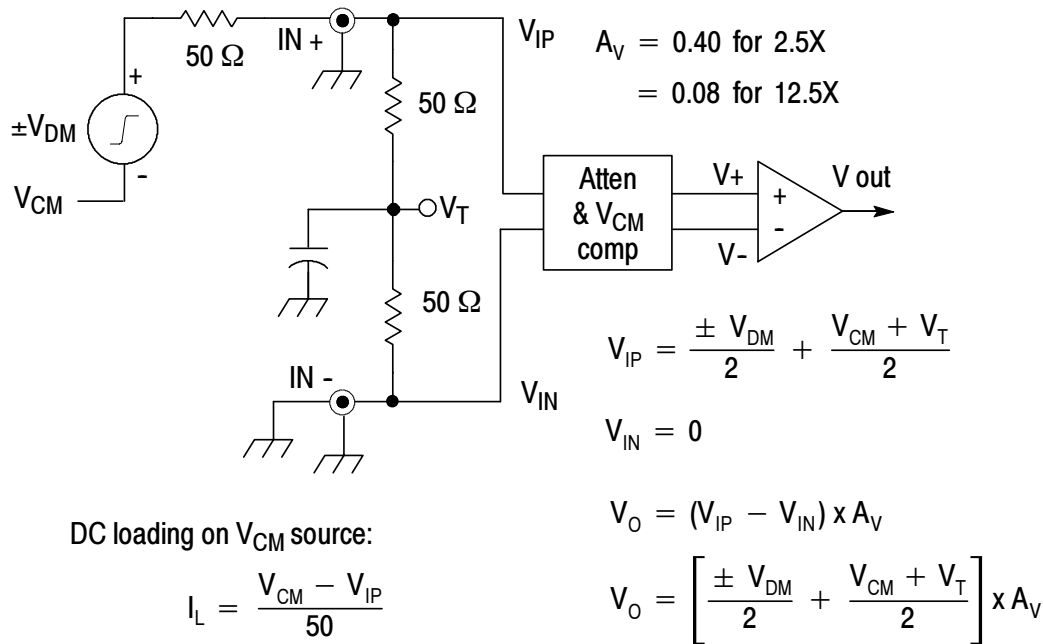
**Figure 21: 50 ohm termination on (-) input**

The equations for this topology show that varying the termination voltage,  $V_T$ , affects the DC loading on the signal source, but does not affect the measured DC voltage. The measured, single-ended DC voltage also represents only half the common-mode input voltage,  $V_{CM}$ , because of the voltage divider network formed from the four 50 Ω resistors and the differential amplifier response.

Although the 50 Ω termination resistors have been laser trimmed for guaranteed performance, it should be noted that the precision of the signal measurement in this topology is affected by the signal source impedance and the impedance of the 50 Ω termination resistor inside the probe positive input connector. This matched source impedance topology is the only single-ended topology that can be correctly used with Auto mode.

**Shorting Termination on (-) Input.**

An alternative single-ended measurement topology with a shorting termination on the (-) input is shown in Figure 22. The general equations describing the response and loading of this topology are also shown. The equations for this topology show identical loading of the signal source when compared to the 50 Ω termination topology. This is because the termination voltage,  $V_T$ , effectively isolates input signal loading from the termination on the probe negative input.



**Figure 22: Shorting termination on (-) input**

The measured single-ended signal response for this topology differs from the 50 Ω termination topology. The measured AC voltage,  $V_{DM}$ , is the same for both single-ended topologies, but the measured DC voltage is affected by both the common-mode input voltage,  $V_{CM}$ , and the termination voltage,  $V_T$ .

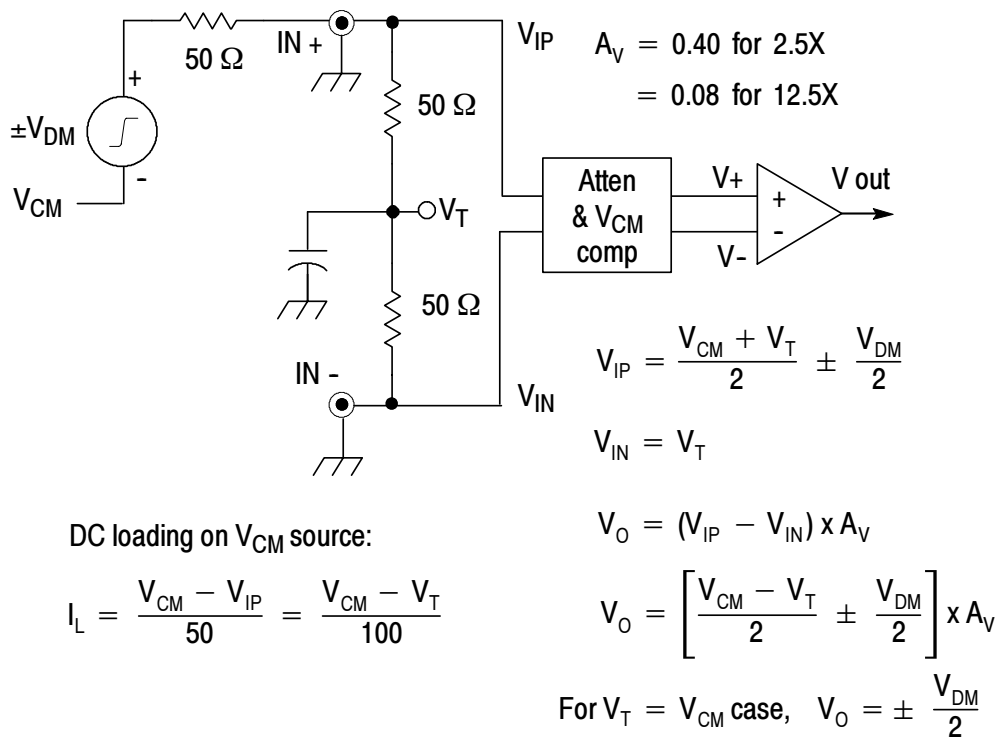
In the special case where the termination voltage is set equal to the common-mode input voltage, the input signal DC loading is minimized and the measured DC output voltage equals the full

common-mode input voltage, scaled by the probe attenuation. The intelligent TekConnect probe interface automatically accounts for the probe attenuation setting and a TekConnect oscilloscope will display the full single-ended input signal when  $V_T$  equals  $V_{CM}$ .

Although this topology displays the correct DC common-mode voltage, it also has a greater risk of exceeding the probe dynamic range and overdriving the probe amplifier.

**Open (-) Input.**

Another alternative single-ended measurement topology is shown in Figure 23. In this case, the (-) input is left open, effectively keeping it at the  $V_T$  voltage level. The general equations describing the response and loading of this topology are also shown.



**Figure 23: Open (-) input**

The measured single-ended response for this topology has the same AC voltage,  $V_{DM}$ , as the other topologies, but has a common-mode voltage term that is proportional to the difference between  $V_{CM}$  and the termination voltage,  $V_T$ . In the special but common case, where  $V_T = V_{CM}$ , only the AC component is displayed, somewhat like an AC-coupled condition.

### Single-Ended Measurement Procedure

The description of characteristics of the three alternative single-ended measurement topologies suggests the following procedure for making single-ended measurements on serial data signals that require light DC loading, (for example, when  $V_T = V_{CM}$ ):

First, determine the common-mode input voltage,  $V_{CM}$ , of the single-ended signal by making a measurement with the 50  $\Omega$  termination topology shown in Figure 21 on page 51. With this topology and the Termination Voltage Select set to Auto mode, the common-mode input voltage can be measured with a DMM on the Termination Voltage Monitor output pins.

Note that measuring the common-mode input voltage on the single-ended signal using this topology is more accurate than using a differential measurement topology, where the measured common-mode voltage is the average between the two single-ended signals that comprise the differential signal. The common-mode voltage for each of the single-ended inputs that comprise the differential signal should be measured independently and recorded for use in the second step of this procedure.

Next, since the 50  $\Omega$  termination topology only displays half the common-mode input voltage, it is now necessary to switch to the shorting termination topology shown in Figure 22 on page 52. This can be done simply by changing the termination attached to the (-) input from a 50  $\Omega$  SMA termination to an SMA shorting termination.

Since Auto mode only works with matched-source impedances on both probe inputs, it is also necessary to switch the Termination Voltage Select to either Int or Ext mode. The termination voltage should be set to the voltage measured in the first step. This can be done easily in Int mode, but requires a TekConnect oscilloscope that has support for probe termination voltage select.

Setting the termination voltage in Ext mode requires the use of an external power supply and the accessory cables supplied with the probe. Once the termination voltage has been set to match the DC common-mode input voltage, the complete input signal is displayed with the shorting termination topology. This shorting termination topology, however, has the highest risk of exceeding the probe dynamic range. Dynamic range calculations for single-ended measurements will now be described.

### Single-Ended Dynamic Range

The dynamic range of the probe has been specified for differential measurements, as described in the differential measurement topology section. When single-ended measurements are made, the input common-mode voltage is no longer nulled out, but becomes a differential mode DC signal that must be within the input dynamic range of the probe to be measured accurately.

The specified dynamic range for differential signals, which is expressed as a differential peak-to-peak voltage, can be converted to a more conventional voltage range for single-ended signal measurements as shown in Table 6 below.

**Table 6: Differential to single-ended conversion table**

Attenuation setting	Differential measurement dynamic range	Single-ended measurement dynamic range
2.5X	625 mVp-p	±0.3125 V
12.5X	3.0 Vp-p	±1.5 V

Because the common-mode DC voltage of many serial data signals is larger than the signal differential mode voltage, the relatively small single-ended dynamic range in the 2.5X attenuation setting may not be adequate. As a result, single-ended measurements will generally be made using the 12.5X attenuation setting.

In the case where single-ended measurements are made on signals with a large common-mode DC voltage, it should be noted that the use of the 50  $\Omega$  termination topology effectively attenuates the DC common-mode voltage by half. If this is taken into account as an



offset to the displayed signal, it allows single-ended signals with a relatively large DC common-mode voltage to be measured.

If only the AC component of the single-ended signal needs to be measured, then the open input topology provides the greatest dynamic range.

Although it is possible to attenuate an input signal with external attenuators to increase the effective dynamic range, care should be taken to account for the signal loading and the impact on the termination voltage of the probe.

If an external attenuator is used, its attenuation accuracy must be taken into account when factoring the impact on measurement accuracy. The increase in attenuation also brings an increase in noise.

## Extending the Input Connections

At times it may be necessary to extend the probe inputs with cables that are longer than the standard 38 inch cables. The 38 inch cables are precision-matched to minimize time-delay differences (skew).

If you substitute cables, you should use low-loss, flexible cables and keep the lengths matched and as short as possible to minimize skew and optimize common-mode rejection. Check the skew between the cables (see page 57), and if necessary, use a pair of phase adjusters to minimize the skew.

Extending the input leads will also increase the skin loss and dielectric loss, which may result in distorted high-frequency pulse edges. You must take into account any effects caused by the extended leads when you take a measurement.

## Checking Cable Skew

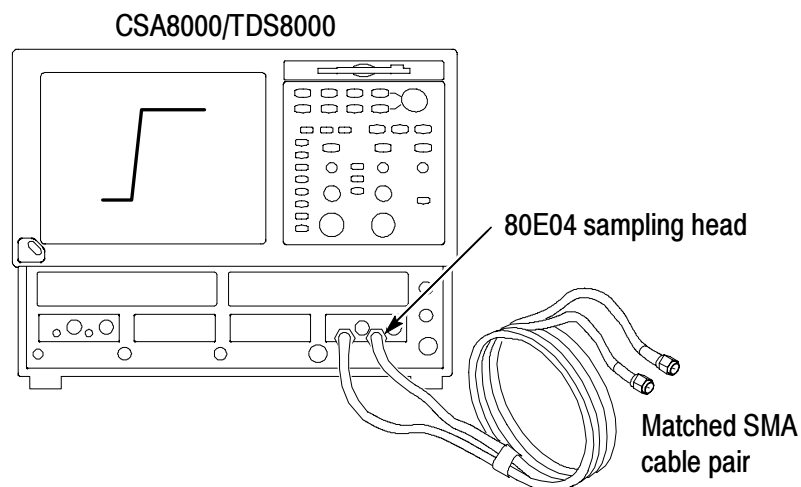
The time-delay difference (skew) between the ends of the matched-delay SMA cable pair supplied with the probe is typically less than 1 ps. If you use a pair of matched, high-quality, low-loss cables other than those supplied with the probe, you can bring the skew to within 1 ps by using a pair of phase adjusters (see *Optional Accessories* on page 8).

You can measure the skew of a pair of matched cables by connecting the cables to a Tektronix 80E04 Sampling Head, configured for a TDR output. Figure 24 shows a typical setup for checking the skew.

1. Turn on the equipment and let it warm up for 20 minutes. Do not connect the cables to the sampling head yet.
2. Do a system compensation for the TDR module, and then verify the skew of the two outputs with the TDR outputs open, using a common-mode TDR drive.

Skew between the two outputs can be compensated with the TDR module deskew control. Refer to your sampling head or oscilloscope manual for instructions.

3. Connect the matched cable pair to the TDR outputs, as shown in Figure 24.



**Figure 24: Checking skew between inputs**

4. The measured skew of the matched cable pair that are supplied with the probe should be less than 1 ps. User-supplied cables may not be nearly as accurate, and may require some trial-and-error testing to select an optimally-matched pair.

Adjust the horizontal scale to locate the pulse (to account for the cable delay; it is approximately 4.5 ns for the cable set supplied with the probe). If you use the system cursors, be aware that the displayed time is the round trip time (step and reflection). You need to divide the displayed time difference by 2 to derive the actual skew.

If you need to minimize the skew of a pair of cables not supplied with the probe, continue with *Adjusting Cable Skew* below.

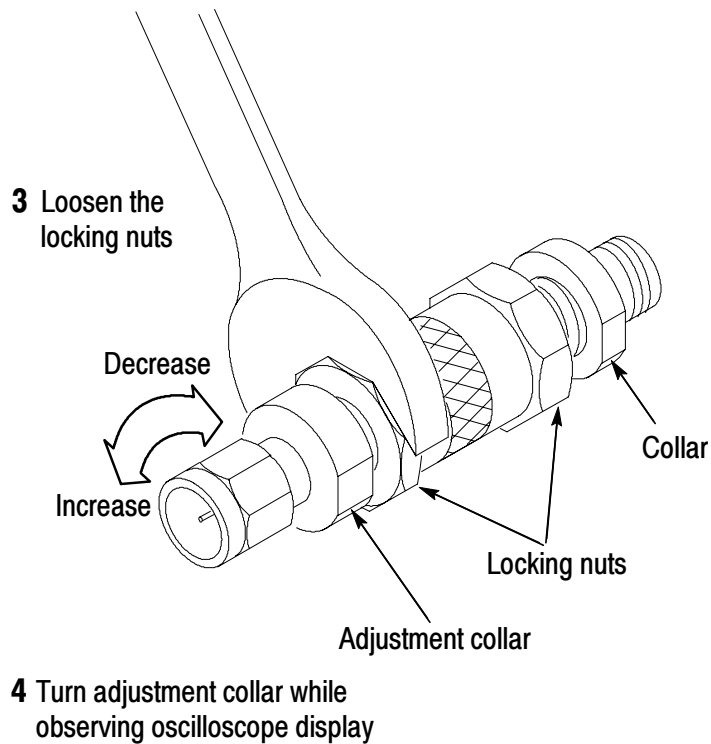
### Adjusting Cable Skew

If you want to minimize the skew introduced by cable pairs other than those supplied with the probe, you can use a pair of phase adjusters (see *Optional Accessories* on page 8) to bring the skew to within 1 ps. The phase adjusters have male and female SMA connectors to simplify connections to your measurement system.

You must add a phase adjuster on each cable to balance the delay and insertion loss introduced by the phase adjuster. You only adjust (add delay to) the phase adjuster on the cable with the shorter delay.

The adjustment range of the phase adjusters on the *Optional Accessories* list is 25 ps, so if you use cable pairs other than those supplied with the probe, the initial delay mismatch should be less than 25 ps.

1. Connect the phase adjusters to the cables.
2. On the cable with the longer delay, loosen the phase adjuster locking nuts, set the phase adjuster to minimum delay (shortest length), and secure the locking nuts. See Figure 25 on page 59.



**Figure 25: Using the phase adjuster**

3. Loosen the locking nuts on the adjuster connected to the other cable (with the shorter delay).
4. While observing the oscilloscope display, turn the collar on the phase adjuster counterclockwise to increase the delay.
5. When the displayed skew on screen is less than 1 ps, tighten the locking nuts.
6. Confirm that the skew is acceptable after you tighten the locking nuts, as the adjustment may change slightly during tightening.
7. Disconnect the cables from the sampling head, and connect them to the P7380SMA probe head.

## Deskewing Probes

You can measure the skew between two P7380SMA probes by using a Tektronix 80E04 Sampling Head configured for a TDR output. Because the skew of the P7380SMA probe inputs is less than 1 ps, two P7380SMA probes can be deskewed using single-ended drive signals from a dual-channel TDR source. The TDR output provides a pair of time-aligned pulses that you can use to compare probe response times, and if necessary, adjust them to match (deskew).

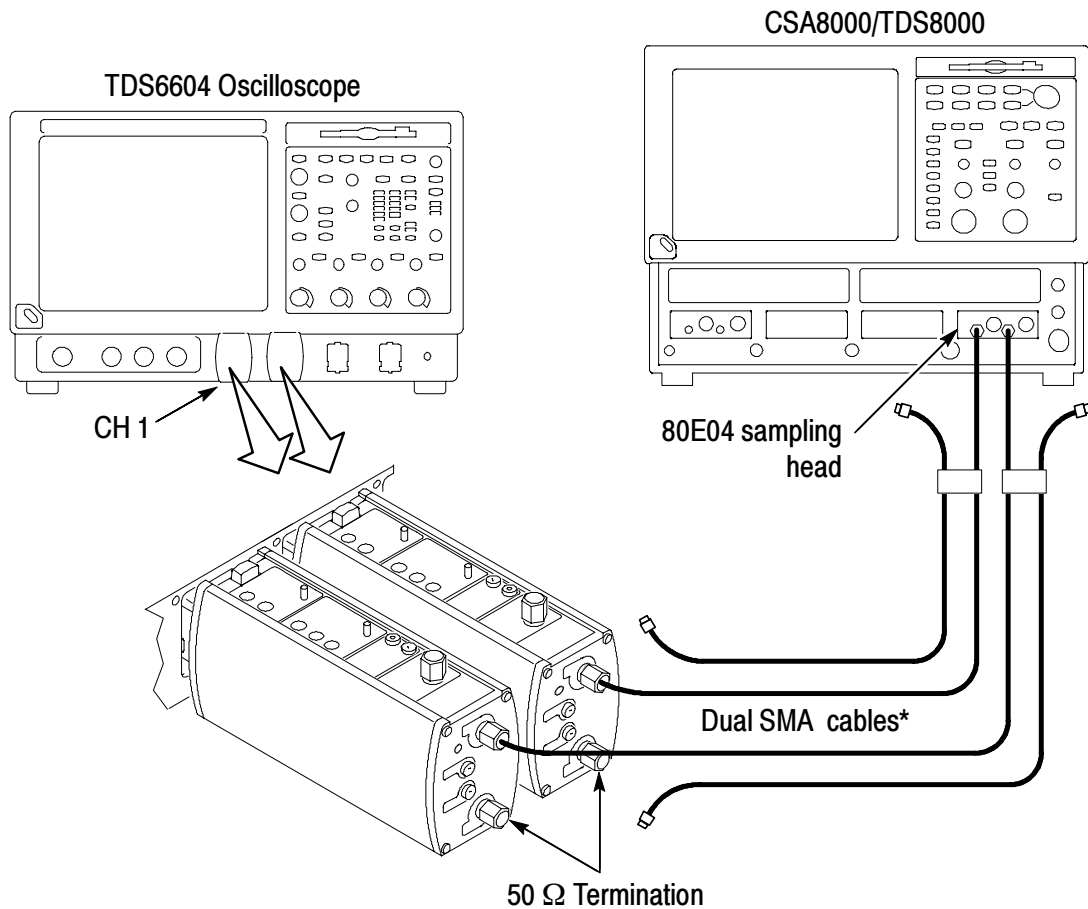
Figure 26 on page 61 shows a setup for checking and deskewing two probes. Deskewing aligns the time delay of the signal path through the oscilloscope channel and probe connected to that channel, to the time delay of other channel/probe pairs of the oscilloscope.

If you need to deskew more than two probes, keep one deskewed probe connected to the sampling head as a reference (after deskewing two probes), and deskew additional probes to that probe. In this procedure, Channel 1 is used as the reference channel.

1. Set up the equipment as shown in Figure 26 and let it warm up for 20 minutes, but don't make any connections to the TDR outputs yet.
2. Do a system compensation for the TDR module, and then verify the skew of the two outputs with the TDR outputs open, using a common-mode TDR drive.

Skew between the two outputs can be compensated with the deskew control. Refer to your sampling head or oscilloscope manual for instructions.

3. Attach the probes to the TDR outputs as shown in Figure 26 on page 61.



Note: \* Use the cables that you will use to connect to your circuit

**Figure 26: Deskewing two P7380SMA probes**

4. Display the channel(s) that you want to deskew.
5. Push the **AUTOSET** button on the instrument front panel.
6. Turn averaging on to stabilize the display.
7. Adjust vertical **SCALE**, and **POSITION** (with active probes, adjusting **offset** may be required) for each channel so that the signals overlap and are centered on-screen.
8. Adjust horizontal **POSITION** so that a triggered rising edge is at center screen.

9. Adjust horizontal **SCALE** so that the differences in the channel delays are clearly visible.
10. Adjust horizontal **POSITION** again so that the rising edge of the Channel 1 signal is exactly at center screen. Now, if you want, you can use the measurement cursors to display the channel-channel skew, and input this value in step 14.
11. Touch the **VERT** button or use the **Vertical** menu to display the vertical control window.
12. Touch the Probe **Deskew** button to display the channel-deskew control window.
13. In the **Channel** box, select the channel that you want to deskew to Channel 1.

---

**NOTE.** If possible, do the next step at a signal amplitude within the same attenuator range (vertical scale) as your planned signal measurements. Any change to the vertical scale after deskew is complete may introduce a new attenuation level (you can generally hear attenuator settings change) and, therefore, a slightly different signal path. This different path may cause up to a 200 ps variation in timing accuracy between channels.

---

14. Adjust the deskew time for that channel so that the signal aligns with that of Channel 1. You can do this several ways: Click the **Deskew** field and input the time value you measured with the cursors in step 10, or you can use the front-panel or on-screen controls to position the signal.
15. Repeat steps 3 through 14 for each additional channel that you want to deskew.

# Reference

This section contains reference information about communication standards and related differential measurements.

## Serial Bus Standards

Table 7 lists some popular high-speed data communication standards that can be measured with the P7380SMA differential probe.

**Table 7: Serial bus standards with dynamic range requirements**

Standard Data Rate	Vdm_max	Vdm_min	Vcm_max	Vcm_min
InfiniBand TX 2.5 Gb/s	1.6 V	1.0 V	1.0 V	0.5 V
InfiniBand RX 2.5 Gb/s	1.6 V	0.175 V	1.0 V	0.5 V
PCI Express TX 2.5 Gb/s	1.2 V	0.8 V	AC	AC
PCI Express RX 2.5 Gb/s	1.2 V	0.175 V	AC	AC
Serial ATA TX 1.5 Gb/s	0.6 V	0.4 V	0.3 V	0.2 V
Serial ATA RX 1.5 Gb/s	0.6 V	0.325 V	0.3 V	0.2 V
XAUI TX 3.125 Gb/s		0.4 V		
XAUI RX 3.125 Gb/s		0.1 V		
OIF-Sxl-5 TX 3.125 Gb/s	1.0 V	0.5 V	1.23 V	0.72 V
OIF-Sxl-5 RX 3.125 Gb/s	1.0 V	0.175 V	1.30 V	1.10 V
LV PECL (stdECL) >12GHz	1.66 V (typ)	1.48 V	1.3 V (vt)	0.5 V (vt)
LV PECL (RSECL) >12GHz	1.05 V	0.70 V	1.3 V (vt)	0.5 V (vt)



## InfiniBand

A number of high-speed serial data communication standards have been introduced to address the need for next generation I/O connectivity. One of these interface standards, InfiniBand, is briefly discussed here.

An InfiniBand communication lane includes two independent differential signaling paths, one for transmit and one for receive, both operating at a 2.5 Gb/s rate. As shown in the Figure 27 example, the differential output parameter is specified as a peak-to-peak voltage difference, and thus the signal swing on each pin of the driver is half that value.

The  $V_{diff}$  signal shown in Figure 27b is measured with a differential probe connected between the two signals in Figure 27a. The  $V_{diff}$  signal represents the result of the receiver processing the two complementary input signals from the driver shown in Figure 27a, and cannot be measured directly as a single-ended signal.

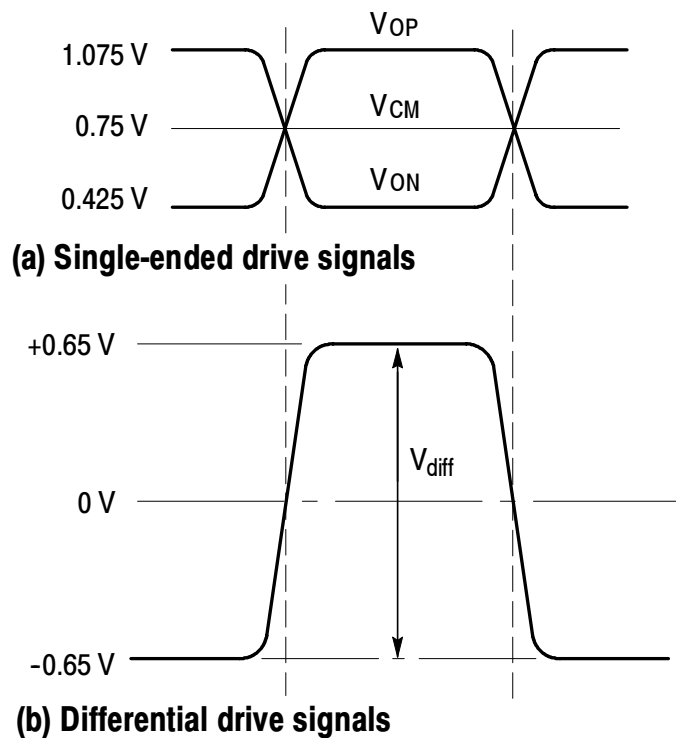


Figure 27: InfiniBand signals

# Appendix A: Specifications

The specifications in Tables 8 through 10 apply to a P7380SMA probe installed on a TDS6604 oscilloscope. The probe must have a warm-up period of at least 20 minutes and be in an environment that does not exceed the limits described in Table 8. Specifications for the P7380SMA differential probe fall into three categories: warranted, typical, and nominal characteristics.

## Warranted Characteristics

Warranted characteristics (Table 8) describe guaranteed performance within tolerance limits or certain type-tested requirements.

Warranted characteristics that have checks in the *Performance Verification* section are marked with the ✓ symbol.

**Table 8: Warranted electrical characteristics**

Characteristic	Description
✓ Differential rise time, 10-90% (probe only) (Main output)	≤55 ps, +20 °C to +30 °C (+68 °F to +86 °F), 100 mV differential step in 2.5X attenuation 500 mV differential step in 12.5X attenuation
✓ DC gain (Main output)	0.40 ±2% (corresponds to 2.5 X attenuation) 0.08 ±2% (corresponds to 12.5 X attenuation)
✓ Termination voltage accuracy (EXT mode) (INT mode) (AUTO mode)	±(0.2% x $V_T$ + 2 mV) over a ±2.5 V $V_T$ range ±(0.3% x $V_T$ + 2 mV) over a ±2.5 V $V_T$ range ±(2.5% x $V_{CM}$ + 20 mV) over a ±2.5 V $V_{CM}$ range
✓ Output offset voltage (Main output) $V_{CM} = 0$ V, $V_{DM} = 0$ V, $V_T = 0$ V	±2.5 mV +20 °C to +30 °C (+68 °F to +86 °F)
✓ Differential-mode input resistance	100 Ω ±2%
Maximum nondestructive input voltage $V_T = 0$ V, applied < 5 minutes	±5 V (DC + peak AC) on either SMA input

**Table 8: Warranted electrical characteristics (Cont.)**

Characteristic	Description
Maximum nondestructive external termination input voltage	±15 VDC
Temperature	Operating: 0 to +40 °C (+32 to +104 °F) Nonoperating: -55 to +75 °C (-131 to +167 °F)
Humidity	Operating: 0-90% RH, tested at +30 to +40 °C (+68 to +104 °F) Nonoperating: 0-90% RH, tested at +30 to +60 °C (+68 to +140 °F)

## Typical Characteristics

Typical characteristics (Tables 9 and 11) describe typical but not guaranteed performance.

**Table 9: Typical electrical characteristics**

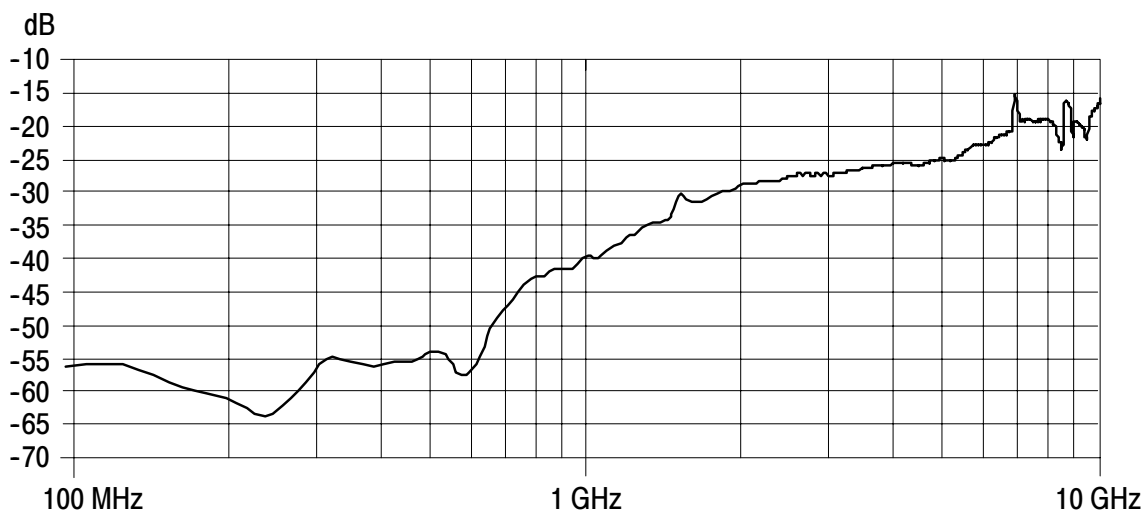
Characteristic	Description
Differential bandwidth (probe only) Main output	DC to ≥8 GHz (-3 dB)
Aux output	DC to ≥8 GHz (-6 dB)
Differential rise time, 20-80% (probe only, Main and Aux output)	≤35 ps, +20 °C to +30 °C (+68 °F to +86 °F), 100 mV differential step in 2.5X attenuation 500 mV differential step in 12.5X attenuation
Differential rise time, 10-90% (probe only, Aux output)	≤55 ps, +20 °C to +30 °C (+68 °F to +86 °F), 100 mV differential step in 2.5X attenuation 500 mV differential step in 12.5X attenuation
Single-ended rise time, 10-90%, (probe only, Main and Aux output)	≤55 ps, +20 °C to +30 °C (+68 °F to +86 °F), 250 mV step
Differential signal range	0.625 Vp-p (2.5 X attenuation) 3.0 Vp-p (12.5 X attenuation)

**Table 9: Typical electrical characteristics (Cont.)**

Characteristic	Description
Differential signal input skew	<1 ps (with matched SMA cable pair)
Differential input return loss	>27 dB @5 GHz (VSWR <1.09:1) >20 dB @8 GHz (VSWR <1.22:1)
Termination voltage range	$\pm 2.5$ V
Termination voltage driver current	$\pm(82.5 \text{ mA} \pm 8 \text{ mA})$ overload
Common-mode DC input signal range	$\pm 2.5$ V
Common-mode input return loss	>27 dB @5 GHz (VSWR <1.09:1) >20 dB @8 GHz (VSWR <1.22:1)
Common-mode rejection ratio (Main output, see Figure 28 on page 68 for plot)	>50 dB to 100 MHz >35 dB to 1 GHz >20 dB to 5 GHz >15 dB to 8 GHz
Common-mode rejection ratio (Aux output)	>45 dB to 100 MHz >35 dB to 1 GHz >20 dB to 5 GHz >15 dB to 8 GHz
Linearity	$\pm 1\%$ or less of dynamic range
Delay time (includes standard cables)	5.4 ns $\pm 100$ ps, relative to a TCA-SMA adapter
Noise, referred to input	13 nV/ $\sqrt{\text{Hz}}$ (2.5 X attenuation) 40 nV/ $\sqrt{\text{Hz}}$ (12.5 X attenuation)
DC gain (Aux output)	0.40 $\pm 2.5\%$ (corresponds to 2.5 X attenuation) 0.08 $\pm 2.5\%$ (corresponds to 12.5 X attenuation)
Output offset voltage (Aux output)	$\pm 15$ mV, +20 °C to +30 °C (+68 °F to +86 °F)
Output return loss (Aux output)	>20 dB to 1 GHz (VSWR <1.22:1) >9 dB to 5 GHz (VSWR <2.10:1) >5 dB to 8 GHz (VSWR <3.60:1)
Output offset voltage (Main output) $V_{\text{CM}} = 0 \text{ V}, V_{\text{T}} = \pm 2.0 \text{ V}$ $V_{\text{CM}} = \pm 2.5 \text{ V}, V_{\text{T}} = 0 \text{ V}$	< $\pm 5$ mV, +20 °C to +30 °C (+68 °F to +86 °F) < $\pm 5$ mV, +20 °C to +30 °C (+68 °F to +86 °F)

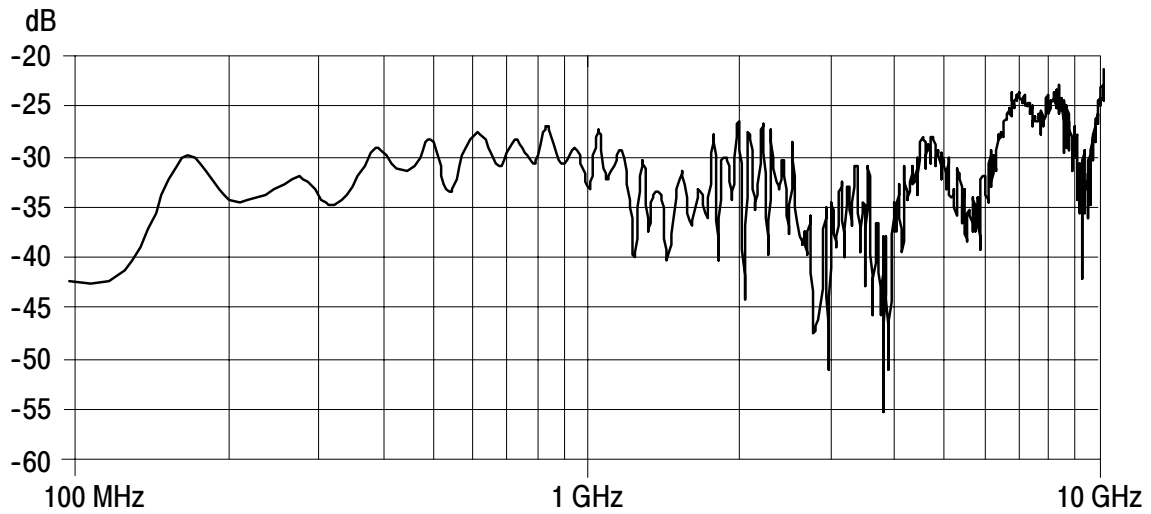
**Table 9: Typical electrical characteristics (Cont.)**

Characteristic	Description
DC offset drift	-50 $\mu\text{V}/^\circ\text{C}$ or less at output of probe (results in -0.125 mV/ $^\circ\text{C}$ or less (2.5 X), or -0.625 mV/ $^\circ\text{C}$ or less (12.5 X) displayed on screen)
DC voltage measurement accuracy (referred to input)	$\pm(2\%$ of input + 6.25 mV + 6.25 mV) (2.5 X) $\pm(2\%$ of input + 31.25 mV + 30.0 mV) (12.5 X)  gain error = $\pm 2\%$ of input voltage  output zero offset (referred to input) = $\pm 6.25$ mV (2.5 X) $\pm 31.25$ mV (12.5 X)  linearity error = $\pm 1.0\%$ of: 625 mV dynamic range = 6.25 mV (2.5 X) 3.0 V dynamic range = 30.0 mV (12.5 X)

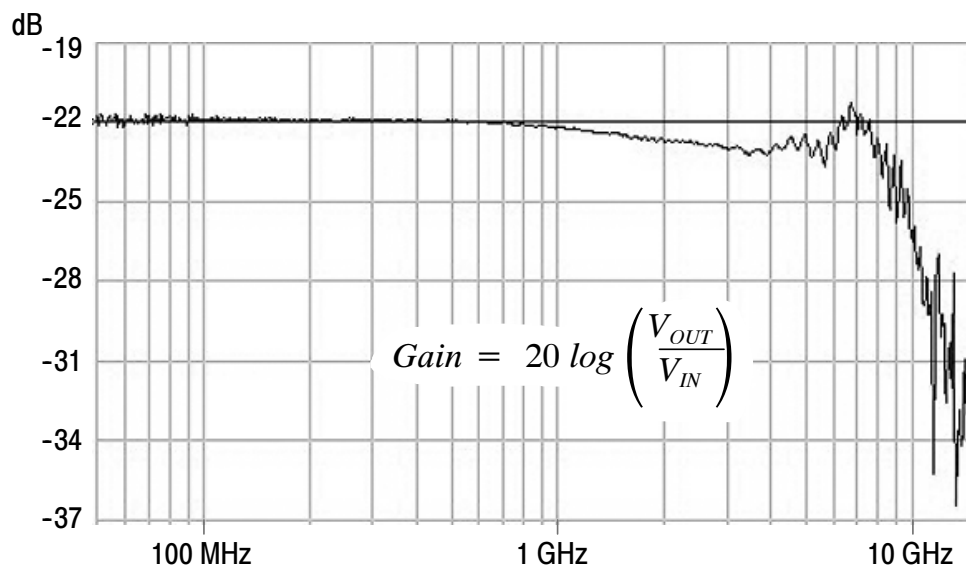


**Figure 28: Typical CMRR plot**

Figures 29 and 30 show typical differential input return loss and differential-mode bandwidth plots for the probe.

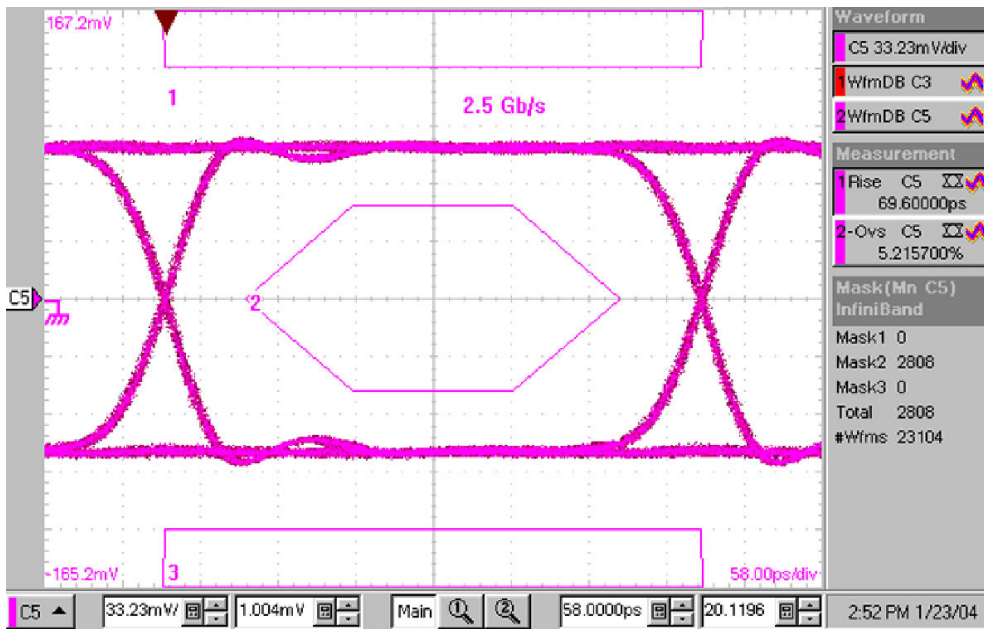


**Figure 29: Typical differential input return loss**

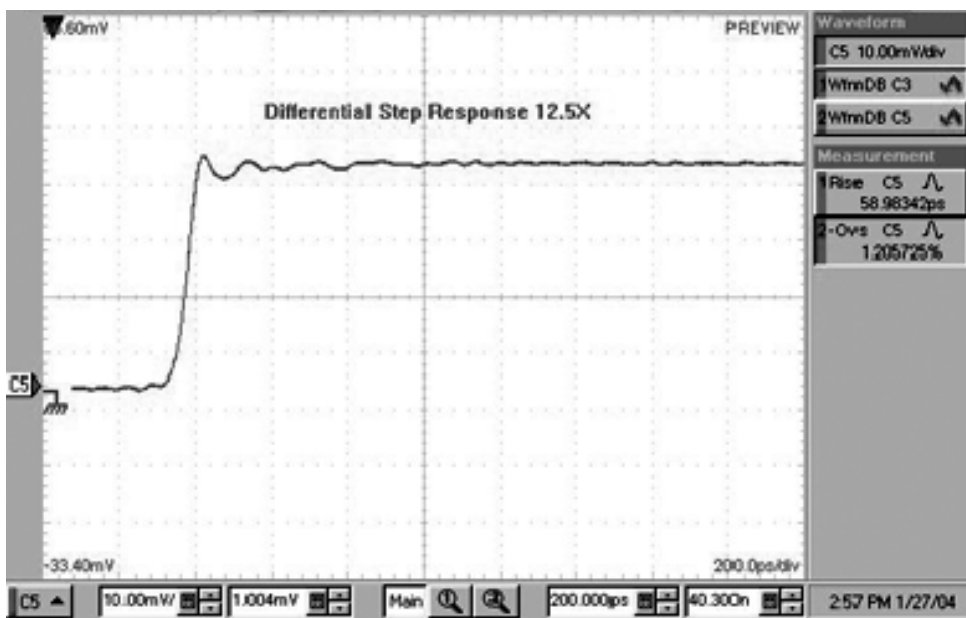


**Figure 30: Typical differential-mode bandwidth**

Figures 31 and 32 show a typical eye pattern of an InfiniBand signal and the typical step response, as measured with the probe.



**Figure 31: Typical eye pattern from an InfiniBand signal**



**Figure 32: Typical differential step response**

## Nominal Characteristics

Nominal characteristics (Table 10) describe guaranteed traits, but the traits do not have tolerance limits.

**Table 10: Nominal electrical characteristics**

Signal input configuration	Differential (two SMA inputs, + and - )
Input coupling	DC
Attenuation	2.5 X and 12.5 X <sup>1</sup>
Common-mode input resistance	50 $\Omega$ $\pm$ 1% (internally per side)
Termination voltage input configuration	DC (two 0.080 in jacks, + and - )
Termination voltage buffer input resistance	100 K $\Omega$
Termination voltage output monitor	DC (two 0.040 in jacks, + and - )
Termination voltage output monitor resistance	1 K $\Omega$
Output coupling and termination	DC, terminate output into 50 $\Omega$
Auxiliary signal output	SMA output

<sup>1</sup> **All TekConnect host instruments recognize this gain setting and adjust the Volts/Div setting to correspond to a normal 1-2-5 sequence of gains.**

## Mechanical Characteristics

The mechanical characteristics of the probe are listed in Table 11, and the dimensions are shown in Figure 33 on page 72.

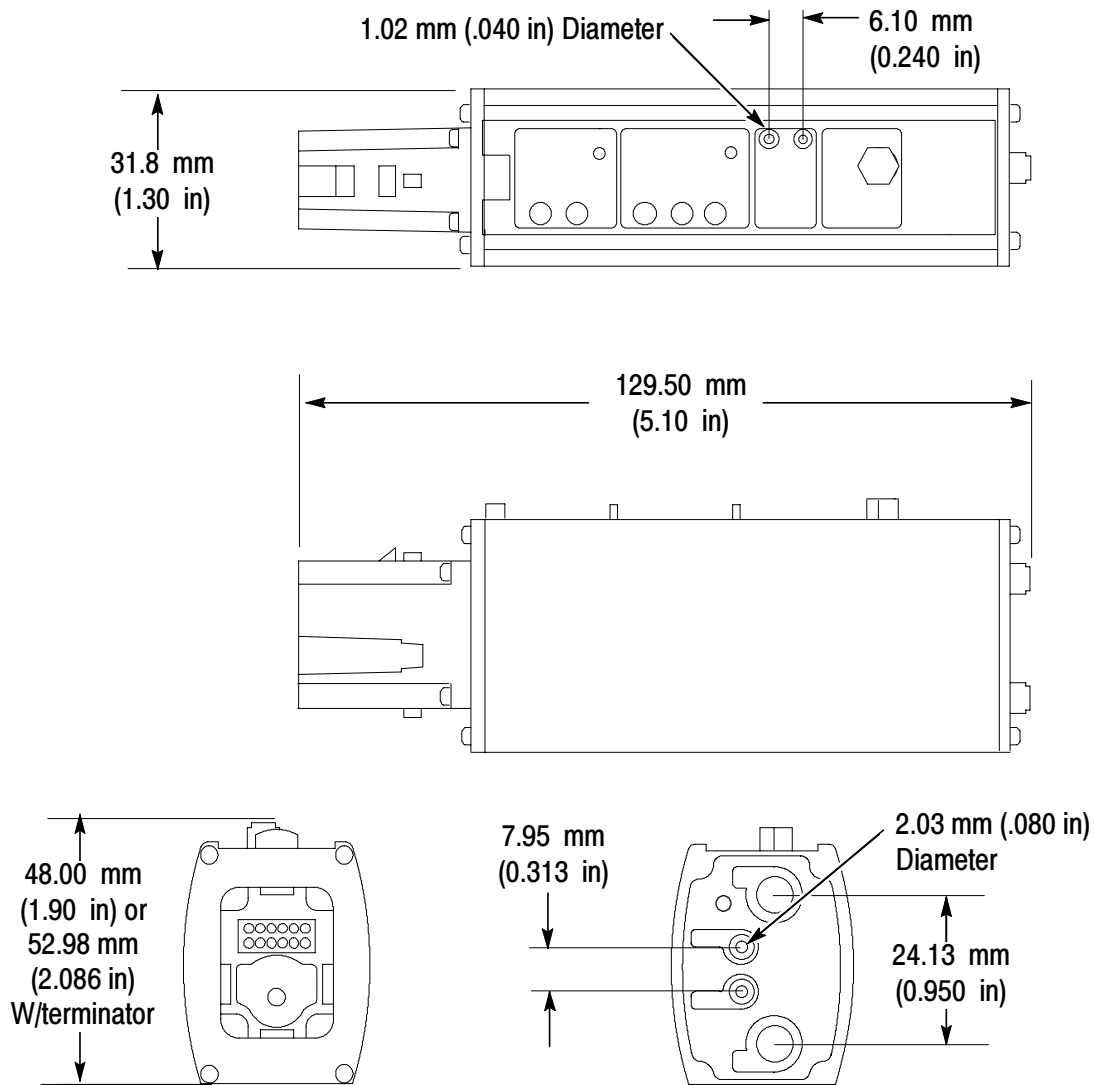
**Table 11: Typical mechanical characteristics**

Dimensions	48.0 mm $\times$ 31.8 mm $\times$ 129.5 mm (1.9 in $\times$ 1.3 in $\times$ 5.1 in)
Unit weight	230 g (0.51 lb)



**Table 11: Typical mechanical characteristics (Cont.)**

Shipping weight (includes shipping materials)	1.38 kg (3.1 lb)
Standard cable assembly length	0.96 m (38 in)



**Figure 33: Probe dimensions**

## Appendix B: Performance Verification

Use the following procedures to verify specifications of the probe. The recommended calibration interval is one year.

These procedures test the following specifications:

- Differential mode input resistance
- Termination voltage accuracy
- Output offset zero
- DC gain accuracy
- Differential mode rise time

### Equipment Required

Refer to Table 12 for a list of the equipment required to verify the performance of your probe.

**Table 12: Equipment required for performance verification**

Item description	Performance requirement	Recommended example <sup>1</sup>
Oscilloscope	TekConnect interface	Tektronix TDS6604, TDS7704, TDS6604B <sup>2</sup> , or TDS6804B <sup>2</sup>
Sampling Oscilloscope		Tektronix TDS8000
Sampling Module	20 GHz bandwidth	Tektronix 80E04
Sampling Module	12 GHz bandwidth	Tektronix 80E02
TekConnect Probe Interface Module with semi-rigid cable	Firmware version V:1.2 or above	Tektronix 80A03, with 174-4857-XX cable
DMM (2), with leads	0.1 mV and 0.01 $\Omega$ resolution	Fluke 187 or equivalent
Dual Power Supply	5.0 VDC at 200 mA	B+K Precision 1760A or equivalent

**Table 12: Equipment required for performance verification (Cont.)**

Item description	Performance requirement	Recommended example <sup>1</sup>
Feedthrough Termination	BNC, 50 $\Omega$ $\pm$ 0.05 $\Omega$	011-0129-00
Attenuators (2)	SMA, 50 $\Omega$ , 5X attenuation	015-1002-01
Coaxial cable	Male-to-Male SMA	012-0649-00
Coaxial cable	Dual, matched-delay Male-to-Male SMA	174-4944-00 <sup>3</sup>
Coaxial cable	Male-to-Male BNC, 50 $\Omega$	012-0057-01
Test leads (2)	Banana plug ends, red	012-0031-00
Test leads (2)	Banana plug ends, black	012-0039-00
Test leads	0.080 in pin-to-Banana plug ends, one each color	012-1674-00 (red) <sup>3</sup> 012-1675-00 (black) <sup>3</sup>
Adapters (3)	SMA 50 $\Omega$ termination	015-1022-00 <sup>3</sup>
Adapter	SMA short-circuit	015-1020-00 <sup>3</sup>
Adapters (2)	0.040 in-to-0.080 in pin jack	012-1676-XX <sup>3</sup>
Adapter	See page 75	Tektronix TCA-SMA
Adapter	SMA Male-to-BNC Female	015-1018-00
Adapters (2)	BNC Male-to-SMA Female	015-0572-00 <sup>4</sup>
Adapters (3)	BNC Female-to-Dual Banana	103-0090-00
Adapter	BNC T	103-0030-00
Adapter	BNC Female-to-BNC Female	103-0028-00
SMA torque wrench	5/16-in, 7 in-lb.	

<sup>1</sup> **Nine-digit part numbers (xxx-xxxx-xx) are Tektronix part numbers.**

<sup>2</sup> **This oscilloscope features Int mode control (see page 79 for test).**

<sup>3</sup> **Standard accessory included with the probe.**

<sup>4</sup> **One adapter is included with the probe.**

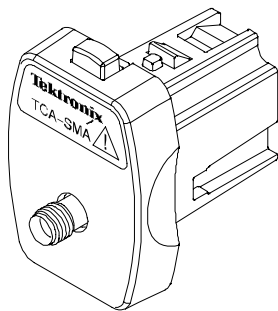
## Special Adapters Required

Some of the adapters listed in Table 12 are available only from Tektronix. These adapters are described on the following pages.

### TekConnect-to-SMA Adapter

The TekConnect-to-SMA Adapter, Tektronix part number TCA-SMA, allows signals from an SMA cable or probe to be connected to a TekConnect input. See Figure 34. Connect and disconnect the adapter the same way as you do the probe.

This adapter is an oscilloscope accessory that may be used for measurement applications, as well as these performance verification procedures.

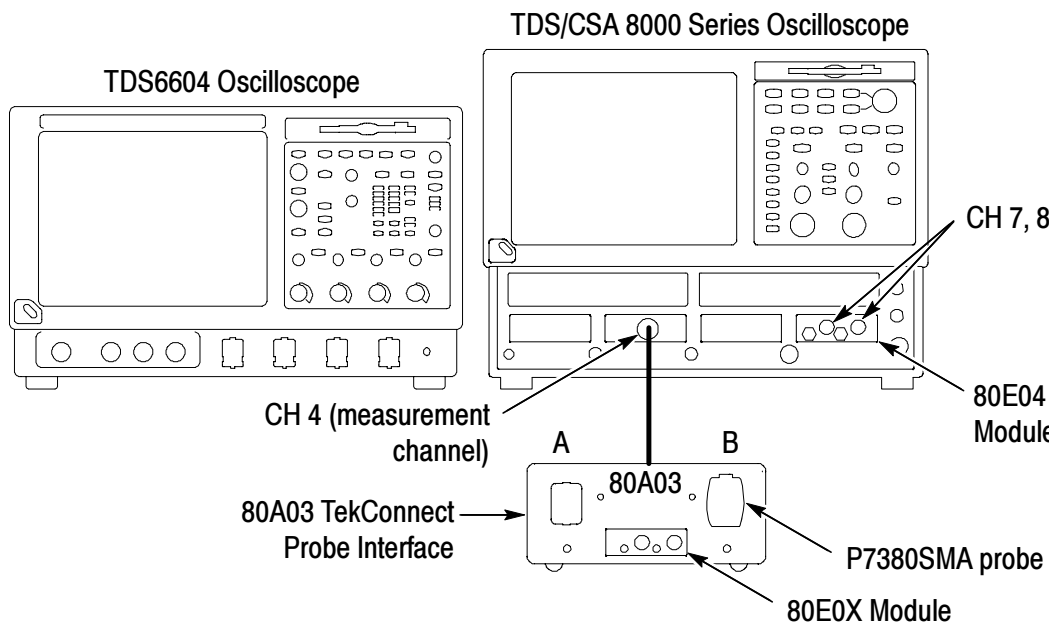


**Figure 34: TekConnect-to-SMA Adapter**

## Equipment Setup

The following tests use two oscilloscopes; use this procedure to set up and warm the equipment to test the probe. Wear the antistatic wriststrap when performing these procedures.

1. Connect the 80A03 TekConnect probe interface to channels 3 and 4 of the TDS8000 oscilloscope. See Figure 35.
2. Connect the 80E0X module to the 80A03 TekConnect probe interface.
3. Connect the 80E04 module to channels 7 and 8 of the TDS8000 oscilloscope.
4. Connect a 50  $\Omega$  termination to the Aux Output connector on the probe, and connect the probe to one of the oscilloscopes.
5. Turn on both oscilloscopes and allow 20 minutes for the equipment to warm up.
6. Photocopy the test record on page 90 to record the performance test results.

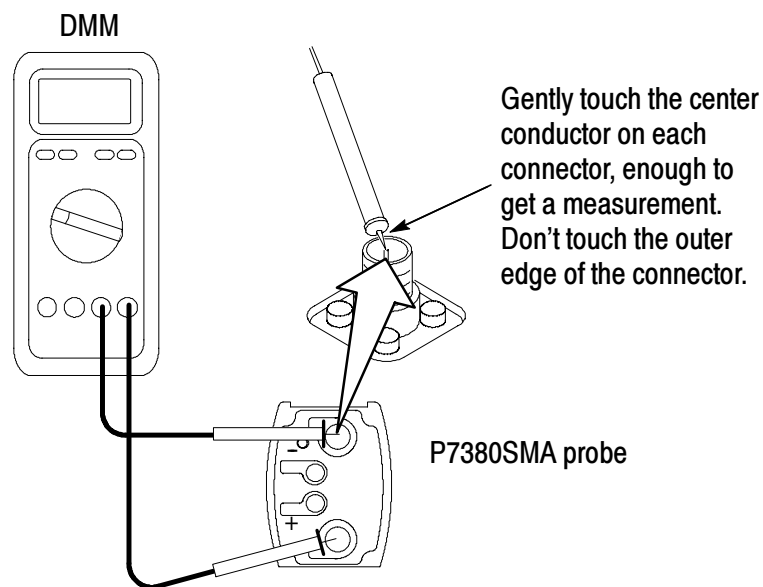


**Figure 35: Preliminary test setup**

## Input Resistance

This test checks the differential mode input resistance—the resistance between each SMA input. The test is performed with the probe disconnected from the oscilloscope.

1. Disconnect the probe from the oscilloscope.
2. Remove the SMA terminations from the two probe inputs and probe the center contacts of the input connectors. See Figure 36.
3. Zero the DMM with its measurement leads connected together on the lowest scale that can measure 100  $\Omega$ .
4. Measure the resistance and write down the value.
5. Reverse the DMM connections and repeat the measurement. Write down the value.
6. Add the two measurements from steps 4 and 5, and divide the total by two. Record the result in the test record.
7. Connect the probe to the oscilloscope channel that you will use in the next test so that the probe warms up to operating temperature.



**Figure 36: Checking differential mode input resistance**

## Termination Voltage Accuracy

These tests compare the termination control voltage that you apply (using the adjustment control for that termination voltage mode), to the termination voltage output at the Vterm monitor jacks.

**NOTE.** The Auto mode LED will flash when the probe inputs are open-circuit, or below a 50 mV threshold. If the LED continues to flash after you connect the inputs, cycle the mode SELECT button.

### Ext Mode

The Ext mode test setup is shown in Figure 37.

1. Plug the probe directly into an oscilloscope channel and set the Vterm Source Select to EXT on the probe.

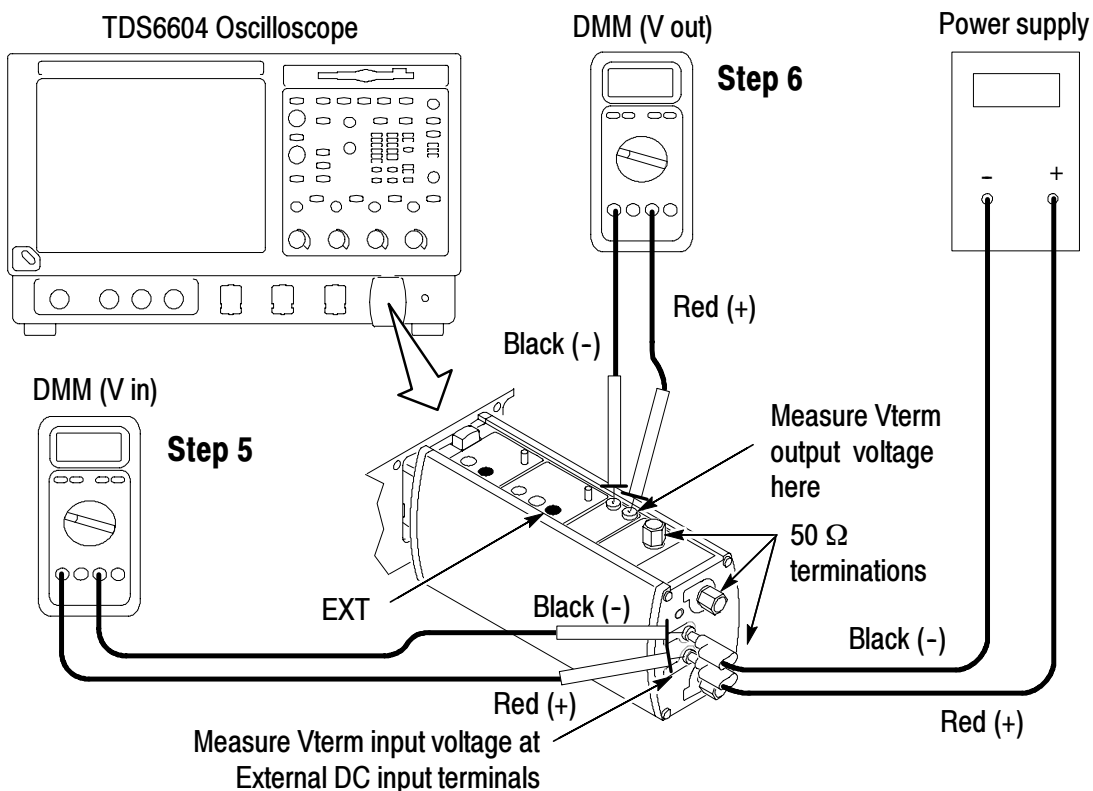


Figure 37: Termination Voltage Accuracy, Ext mode setup

2. Connect the 50  $\Omega$  terminations on the three probe SMA connectors. This sets the common mode input voltage to 0.0 V.
3. The probe attenuation can be set to either 2.5X or 12.5X.
4. Using the 0.080 in pin-to-Banana plug cables, connect the power supply to the external DC input jacks on the front of the probe.
5. Set the power supply as close as practical to 0.000 volts, using a DMM to measure this input voltage at the terminals on the front of the probe. Record this voltage as  $V_{in}$  on the test record.
6. Use the second DMM to measure the output voltage at the termination voltage monitor jacks on the top of the probe. Record this voltage as  $V_{out}$  on the test record, and verify that the  $V_{out}$  voltage is within the specified limits in the min/max columns. For example, within  $\pm 2$  mV of the actual  $V_{in}$  voltage that you measured in the previous step.
7. Repeat steps 5 and 6 for the +2.500 volt and -2.500 volt input values listed in the test record.

### **Int Mode**

If your oscilloscope supports internal mode, use this test to check the accuracy of the internally-generated termination voltages. In Int mode, a graphical user interface in the oscilloscope is used to set the test values to the 0.000, +2.500 and -2.500 volt levels, instead of using external power supplies. You do not need to measure these values in Int mode, as they are digitally set.

See your oscilloscope manual for details on using the interface.

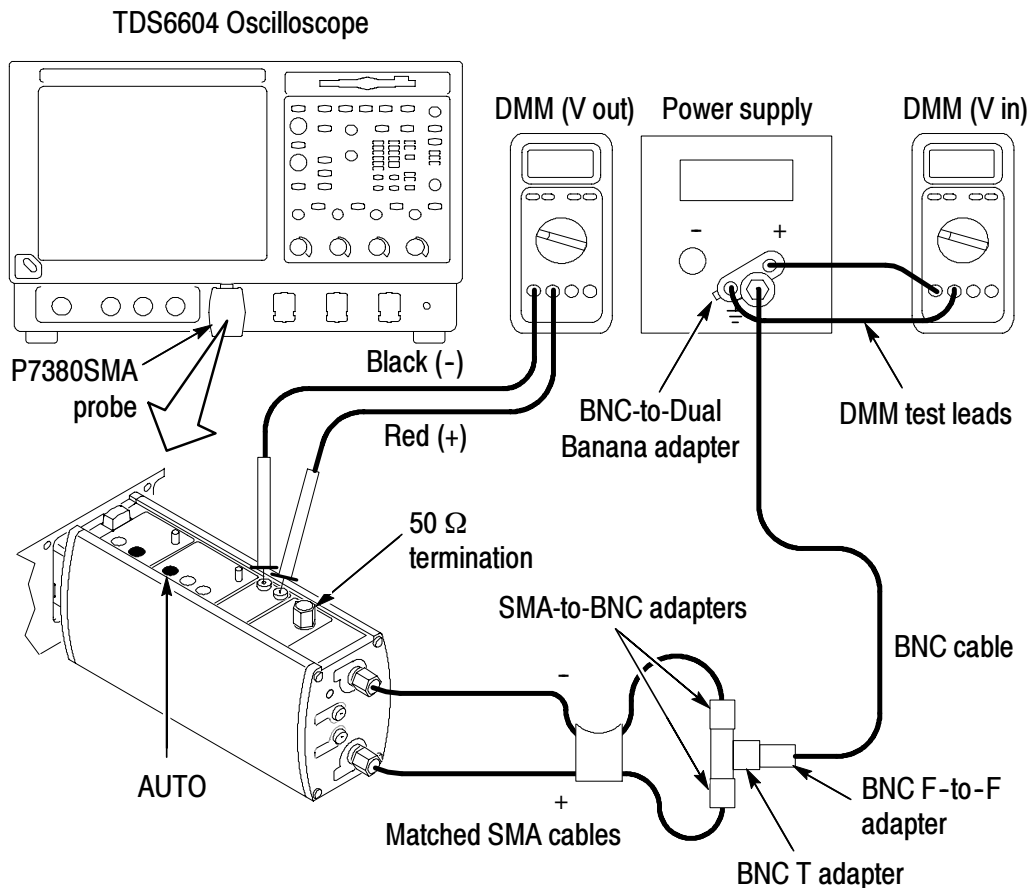
1. Disconnect the power supply from the probe.
2. Set the  $V_{term}$  Source Select to INT on the probe.
3. Use the graphical user interface in the oscilloscope to set the termination voltage to 0.000 V.
4. Use the DMM to verify that the termination voltage output at the  $V_{term}$  monitor jacks on the top of the probe is within the limits on the test record. Record this value as  $V_{out}$  on the test record.
5. Repeat steps 3 and 4 for the +2.500 volt and -2.500 volt input values listed in the test record.



### Auto Mode

In Auto mode, the probe measures the input signal DC common mode voltage and automatically sets the termination voltage to equal that voltage. In this test, the two signal inputs are connected together and driven by an external power supply to set the common mode voltage to the 0.0, +2.500 and -2.500 volt test values.

1. Connect the test setup as shown in Figure 38.



**Figure 38: Termination Voltage Accuracy, Auto mode setup**

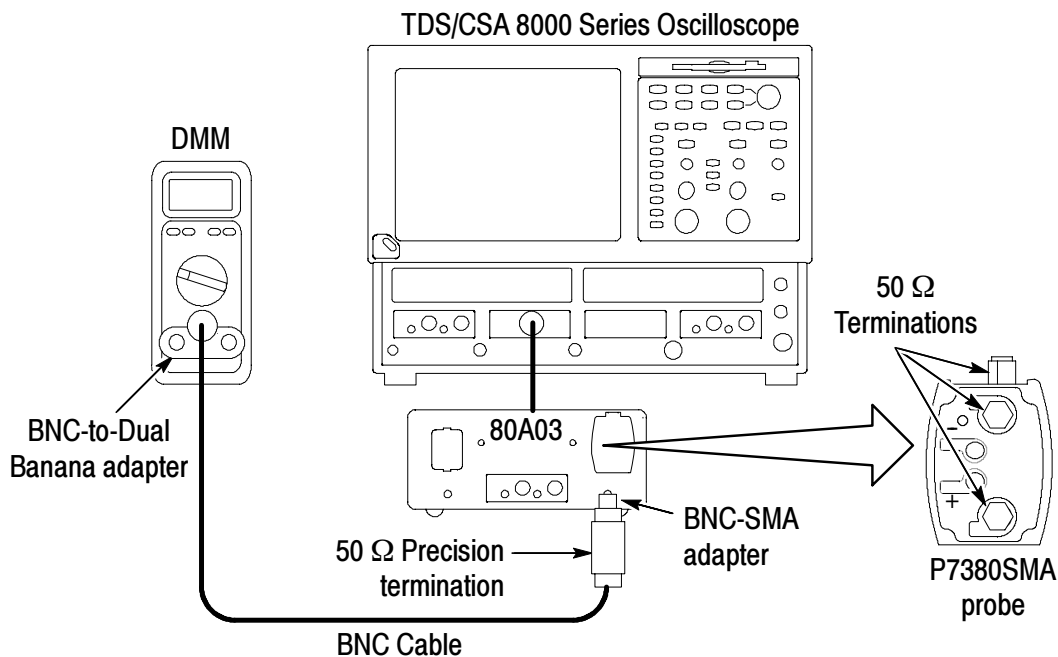
2. Set the  $V_{term}$  Source Select to Auto on the probe.
3. Set the power supply as close as practical to 0.000 volts, using the DMM to measure this input voltage at the terminals on the power supply. Record this voltage as  $V_{in}$  on the test record.

4. Use the second DMM to measure the output voltage at the termination voltage monitor jacks on the top of the probe. Record this voltage as  $V_{out}$  on the test record, and verify that the  $V_{out}$  voltage is within the specified limits in the min/max columns.
5. Repeat steps 3 and 4 for the +2.500 volt and -2.500 volt input values listed in the test record.

## Output Offset Zero

By terminating the two probe SMA inputs with 50  $\Omega$ , this procedure tests the zero output voltage of the probe. The probe output is measured at the SMA connector on the front of the 80A03 interface.

1. Connect the equipment as shown in Figure 39.
2. Connect two 50  $\Omega$  terminations to the two probe SMA inputs on the probe, and plug the probe into the 80A03 module.



**Figure 39: Setup for the output offset zero test**

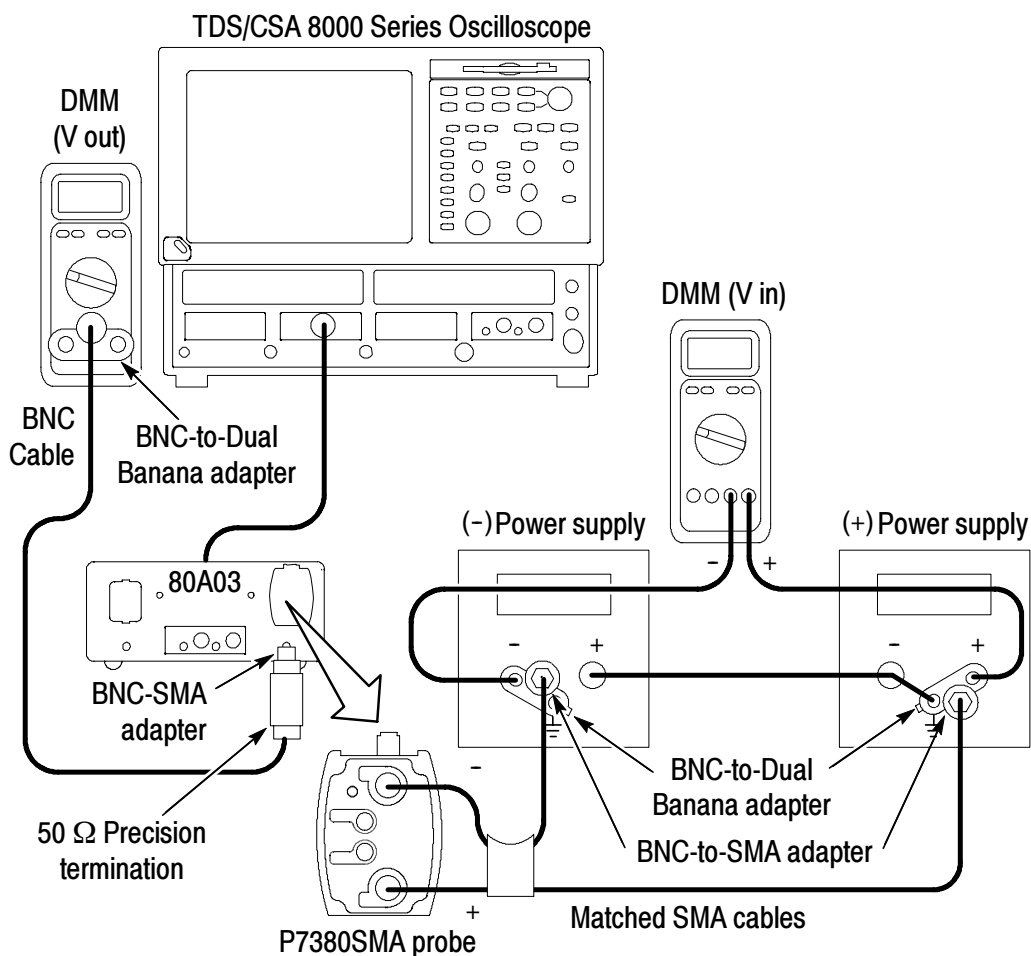
3. Set the Vterm source to Ext on the probe. Leave the external termination control voltage inputs open. This sets the termination voltage to zero.
4. Set the multimeter to read DC volts.
5. Verify that the output voltage is 0 V,  $\pm 2.5$  mV for both the 2.5X and 12.5X attenuation settings.
6. Record the results on the test record.

## DC Gain Accuracy

This test checks the DC gain accuracy of the probe at the two attenuation settings, 2.5X and 12.5X.

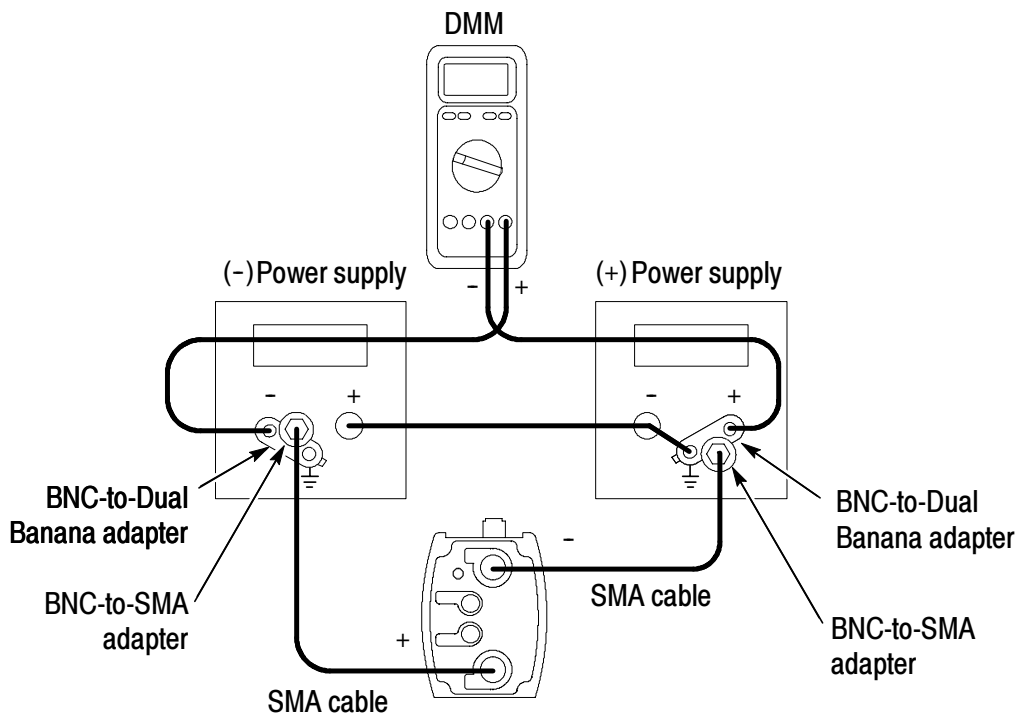
### Gain Check at 2.5X Attenuation

1. Set the attenuation on the probe to 2.5X, and the termination select to Auto.
2. Connect the probe to the power supplies as shown in Figure 40. Make sure the ground tabs on the BNC-to-dual banana plug adapters are connected to the ground connections on the power supplies. Monitor the source voltage with one of the DMMs. Monitor the source voltage with one of the DMMs.



**Figure 40: DC Gain Accuracy setup**

3. Set the voltage on each power supply to approximately +0.125 V (+0.25 V differential total). This represents 80% of the probe dynamic range in this attenuation setting. Record this source voltage as  $V_{in1}$ .
4. Record the output voltage (on the second DMM) as  $V_{out1}$ .
5. Disconnect the BNC-to-dual banana plug adapters from the power supplies. Leave the DMM leads connected to the adapters.
6. Connect the BNC-to-dual banana plug adapters into the opposite power supplies to reverse the voltage polarity to the probe inputs. See Figure 41.
7. Record the actual source voltage (now a negative value), as  $V_{in2}$ .



**Figure 41: Reverse the power supply polarity on the probe inputs**

8. Record the output voltage (on the second DMM) as  $V_{out2}$ .
9. Calculate the gain as follows:  $(V_{out1} - V_{out2}) \div (V_{in1} - V_{in2})$ .

10. Verify that the gain is 0.4,  $\pm 2.0\%$ .
11. Record the calculated gain for the 2.5X setting on the test record.

**Gain Check at 12.5X Attenuation**

12. Set the attenuation on the probe to 12.5X.
13. Repeat steps 2 through 9, but in step 3, set each power supply to +0.6 V (+1.2 V differential total).
14. Verify that the gain is 0.08,  $\pm 2.0\%$ .
15. Record the calculated gain on the test record.

**Rise Time**

This procedure verifies that the probe meets the differential rise time specification. Two rise times are measured; the test system alone, and the test system with the probe included. The probe rise time is calculated using the two measurements.

This test uses the TDR function of the 80E04 sampling head as a fast rise time signal source. A second 80E0X sampling head is used to take the measurements, using an 80A03 TekConnect probe interface. Although the following procedure assigns the TDR and measurement functions to specific oscilloscope channels, any valid channel combination can be used. However, the TDR function is only available on 80E04 sampling heads.

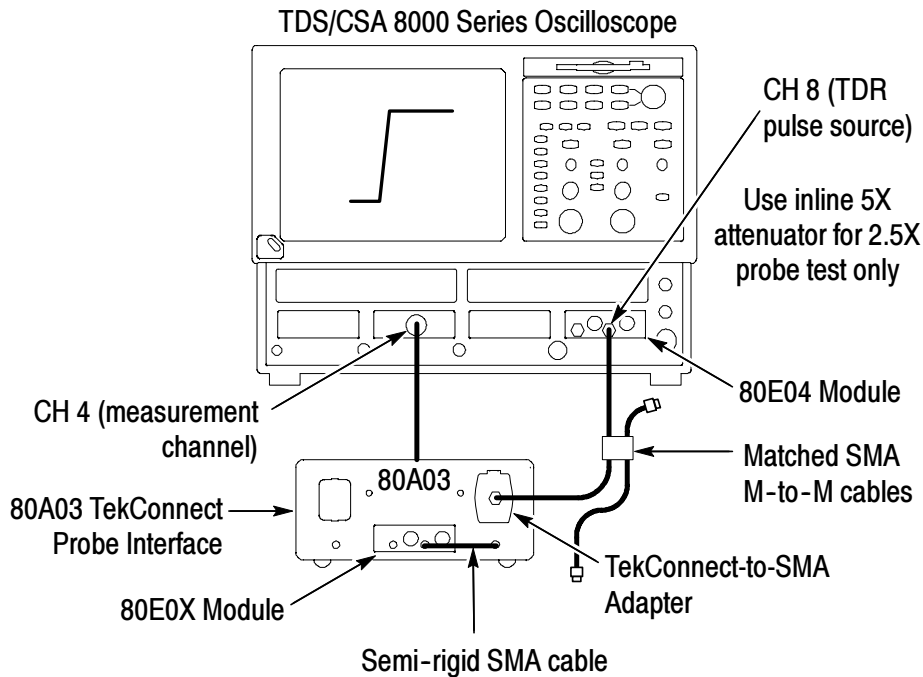
This test checks both of the probe attenuation settings, but due to the differential TDR output amplitude and common mode voltage, inline 5X attenuators must be used when checking the 2.5X attenuation setting on the probe.

**Rise Time Check at 12.5X Attenuation**

1. Remove the probe from the previous test setup.
2. Connect the test equipment as shown in Figure 42 on page 86.



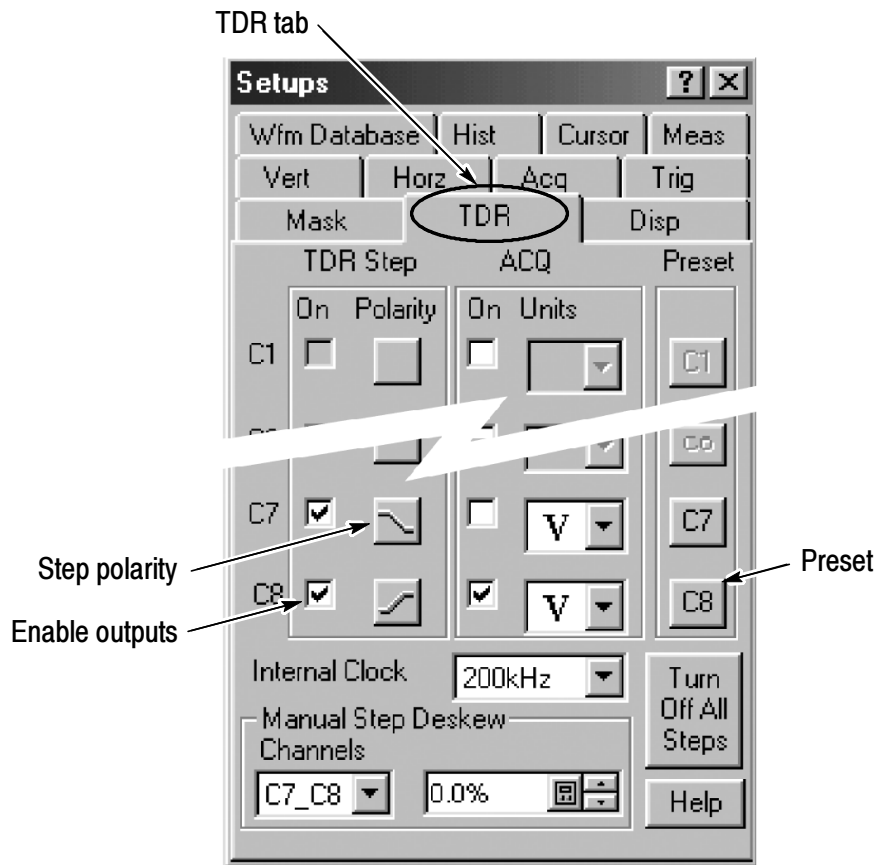
**CAUTION.** To prevent mechanical strain on the connectors, use care when working with SMA connectors: Support equipment and use a torque wrench to tighten connections to 7 in-lbs.



**Figure 42: Test system rise time setup**

**NOTE.** The firmware of the 80A03 TekConnect Probe Interface used to power the probe must be version V:1.2 or above.

3. Turn on Channel 4 and set the vertical scale to 50 mV/div.
4. Set the Channel 7/8 sampling head to TDR mode:  
Press the **SETUP DIALOGS** button and select the **TDR** tab.  
See Figure 43 on page 87.



**Figure 43: Setting the TDR parameters**

5. Set the Channel 7 (C7) **Polarity** to negative (falling).
6. Set the Channel 8 (C8) **Polarity** to positive (rising).
7. Set the **Preset** of Channel 7 and 8 on.

TDR Preset sets Internal Clock in the Trigger menu, turns on the TDR Step in the TDR Setups menu, turns on the channel and selects the acquisition Units in the TDR Setups menu, and sets the horizontal scale, position, and reference.

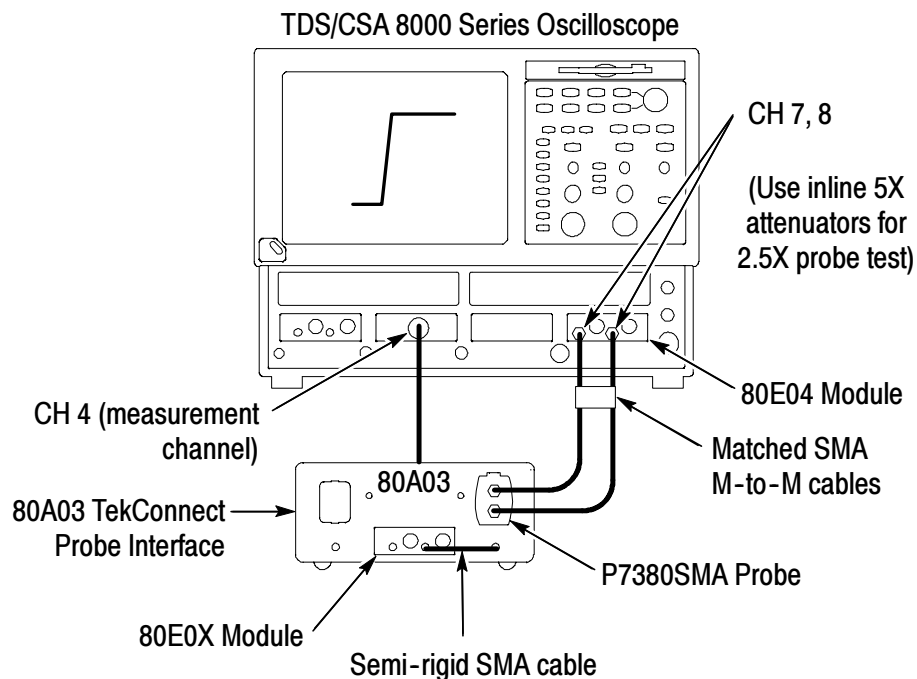
The sampling module will turn on a red light next to the SELECT channel button, indicating that TDR is activated for that channel.

8. Turn off the display for Channel 7 and 8 so that only Channel 4 is shown on screen.



9. Adjust the oscilloscope horizontal and vertical position controls to display a signal similar to that shown in Figure 42.
10. Set the oscilloscope horizontal scale to 20 ps/div and center the waveform.
11. Use the oscilloscope measurement capability to display rise time. Increase the stability of the pulse edge measurement by using averaging, if available. Rise time is measured from the 10% and 90% amplitude points on the waveform. Record the rise time as  $t_s$ .

The following steps instruct you to assemble the test setup that includes the probe, as shown in Figure 44. The system and probe rise time ( $t_{s+p}$ ) that you measure in step 19 is used to calculate the probe rise time ( $t_p$ ) in step 20.



**Figure 44: Test system rise time setup with probe**

12. Remove the TekConnect-to-SMA adapter from the test setup.

13. Connect the probe to the 80A03 TekConnect probe interface.
14. Connect the matched SMA cables to the probe SMA inputs and the 80E04 sampling head (Channels 7 and 8).
15. Set the attenuation on the probe to 12.5X.

The test setup should now be connected as shown in Figure 44.

16. Expand the horizontal scale to help locate the step edge, then adjust horizontal range to 20 ps/div while maintaining the edge view. For a more stable measurement display, turn averaging on.
17. Adjust the vertical scale to 100 mV/div, averaging on.
18. Adjust the horizontal positioning to place the rising edge of the signal on the second vertical and center horizontal graticule lines.
19. Use the oscilloscope measurement capability to display rise time. Rise time is determined from the 10% and 90% amplitude points on the waveform. Record the rise time as  $t_{s+p}$ .
20. Calculate the probe rise time using the following formula:

$$t_p = \sqrt{t_{(s+p)}^2 - t_s^2}$$

21. Record the calculated probe rise time on the test record.

#### **Rise Time Check at 2.5X Attenuation**

The TDR output levels of the 80E04 module must be attenuated when checking the 2.5X attenuation setting on the probe. The attenuators add some delay and a small bandwidth reduction to the test system, so a new system time,  $t_s$ , must be measured to accurately calculate the probe rise time.

22. Disconnect the matched SMA cables from the TDR outputs.
23. Install inline 5X attenuators on the TDR outputs.
24. Repeat steps 2 through 14.
25. Set the attenuation on the probe to 2.5X.
26. Repeat steps 16 through 21 for the 2.5X attenuation setting.

### Test record

Probe Model: \_\_\_\_\_  
 Serial Number: \_\_\_\_\_  
 Certificate Number: \_\_\_\_\_  
 Temperature: \_\_\_\_\_  
 RH %: \_\_\_\_\_  
 Date of Calibration: \_\_\_\_\_  
 Technician: \_\_\_\_\_

Performance test		Minimum	Measured	Maximum
Differential mode input resistance		98 $\Omega$		102 $\Omega$
Termination voltage accuracy				
Ext Mode	Vin @ 0.000 V	Vin - 2 mV	Vin _____ Vout _____	Vin + 2 mV
	Vin @ +2.500 V	Vin - 7 mV	Vin _____ Vout _____	Vin + 7 mV
	Vin @ -2.500 V	Vin - 7 mV	Vin _____ Vout _____	Vin + 7 mV
Int Mode	Vin @ 0.000 V	-0.002 V	Vout	+0.002 V
	Vin @ +2.500 V	+2.4905 V	Vout	+2.5095 V
	Vin @ -2.500 V	-2.4905 V	Vout	-2.5095 V
Auto Mode	Vin @ 0.000 V	Vin - 20 mV	Vin _____ Vout _____	Vin + 20 mV
	Vin @ +2.500 V	Vin - 82 mV	Vin _____ Vout _____	Vin + 82 mV
	Vin @ -2.500 V	Vin - 82 mV	Vin _____ Vout _____	Vin + 82 mV
Output offset zero	2.5X	-2.5 mV		+2.5 mV
	12.5X	-2.5 mV		+2.5 mV
DC gain accuracy	2.5X	0.392		0.408
	12.5X	0.0784		0.0816
Differential rise time	2.5X	NA		55 ps
	12.5X	NA		55 ps

## Appendix C: User Service

This section covers troubleshooting and maintenance for the P7380SMA differential probe.

### Probe/Adapter/Oscilloscope Compatibility

The P7380SMA differential probe is designed to work with all TekConnect-interface oscilloscopes and adapters. However, there may be some cases where all of the probe features may not work properly.

#### Check Compatibility

Before suspecting a problem with your probe, compare the symptoms of your probe with those listed in Table 13.

**Table 13: P7380SMA probe compatibility issues**

Symptom	Likely cause
Int mode for Vterm does not display a control window on the oscilloscope	The oscilloscope does not support this mode. (Instead, the termination voltage defaults to 0 volts.)  If you need to manually set the termination voltage, use Ext mode with an external power supply.
P7380SMA probe does not work with an 80A03 TekConnect Probe Interface Adapter	The LED on the 80A03 Adapter glows red, indicating an incompatible probe.  The 80A03 Adapter requires firmware version V:1.2 or above. Contact Tektronix for information on updating the adapter firmware.

If the probe LEDs flash or otherwise appear to be malfunctioning, an error condition may exist. Check Table 14 on page 92 for a list of LED error conditions.

## Error Conditions

The LEDs on the probe alert you to error or status conditions affecting the probe. Refer to Table 14 for an explanation of these conditions and remedies.

**Table 14: LED error conditions**

Symptom	Cause	Remedy <sup>1</sup>
Auto mode LED flashing	Probe signal inputs are open or AC-coupled	This is not an error, it is a status indicator. The probe is functioning normally.
Both Atten/Dynamic Range LEDs flash after power-on	Internal probe fault	Disconnect the probe from the oscilloscope and reconnect.
Overdrive LED on	Input signal exceeding maximum limit	Remove all signal sources from probe, verify the signal amplitudes do not exceed probe limits, then reconnect.
Overdrive LED flashing	Termination voltage in Auto or EXT mode exceeding maximum limit	Remove termination voltage source from probe, verify the voltage does not exceed probe limits, then reconnect.

<sup>1</sup> **If the remedy does not clear the error condition, the probe is defective and must be returned to Tektronix for repair.**

## Inspection and Cleaning

Protect the probe from adverse weather conditions. The probe is not waterproof.



---

**CAUTION.** *To prevent damage to the probe, do not expose it to sprays, liquids, or solvents. Do not use chemical cleaning agents; they may damage the probe. Avoid using chemicals that contain benzene, benzene, toluene, xylene, acetone, or similar solvents.*

---

Clean the exterior surfaces of the probe with a dry, lint-free cloth or a soft-bristle brush. If dirt remains, use a soft cloth or swab dampened with a 75% isopropyl alcohol solution. A swab is useful for cleaning narrow spaces on the probe. Do not use abrasive compounds on any part of the probe.



---

**CAUTION.** *To prevent damage to the probe, avoid getting moisture inside the probe during exterior cleaning, and use only enough solution to dampen the swab or cloth. Use a 75% isopropyl alcohol solution as a cleanser, and rinse with deionized water.*

---

## Replacement Parts

Due to the sophisticated design of the P7380SMA differential probe, there are no user replaceable parts within the probe. Refer to the *Getting Started* section for a list of replaceable accessories for your probe.

If your probe does not meet the specifications tested in the Performance Verification, you can send the probe to Tektronix for repair. Follow the procedure below to prevent damage to the probe during shipping.

## Preparation for Shipment

If the original packaging is unfit for use or not available, use the following packaging guidelines:

1. Use a corrugated cardboard shipping carton having inside dimensions at least one inch greater than the probe dimensions. The box should have a carton test strength of at least 200 pounds.
2. Put the probe into an antistatic bag or wrap to protect it from dampness.
3. Place the probe into the box and stabilize it with light packing material.
4. Seal the carton with shipping tape.
5. Refer to *Contacting Tektronix* on page viii for the shipping address.